

Four Corner Lot Grading

THE LEGACY 3RD ADDITION

Wichita, Sedgwick County, Kansas

OWNER: VANDERHOFF, ALBERT W & BETTE A
(UNPLATTED)

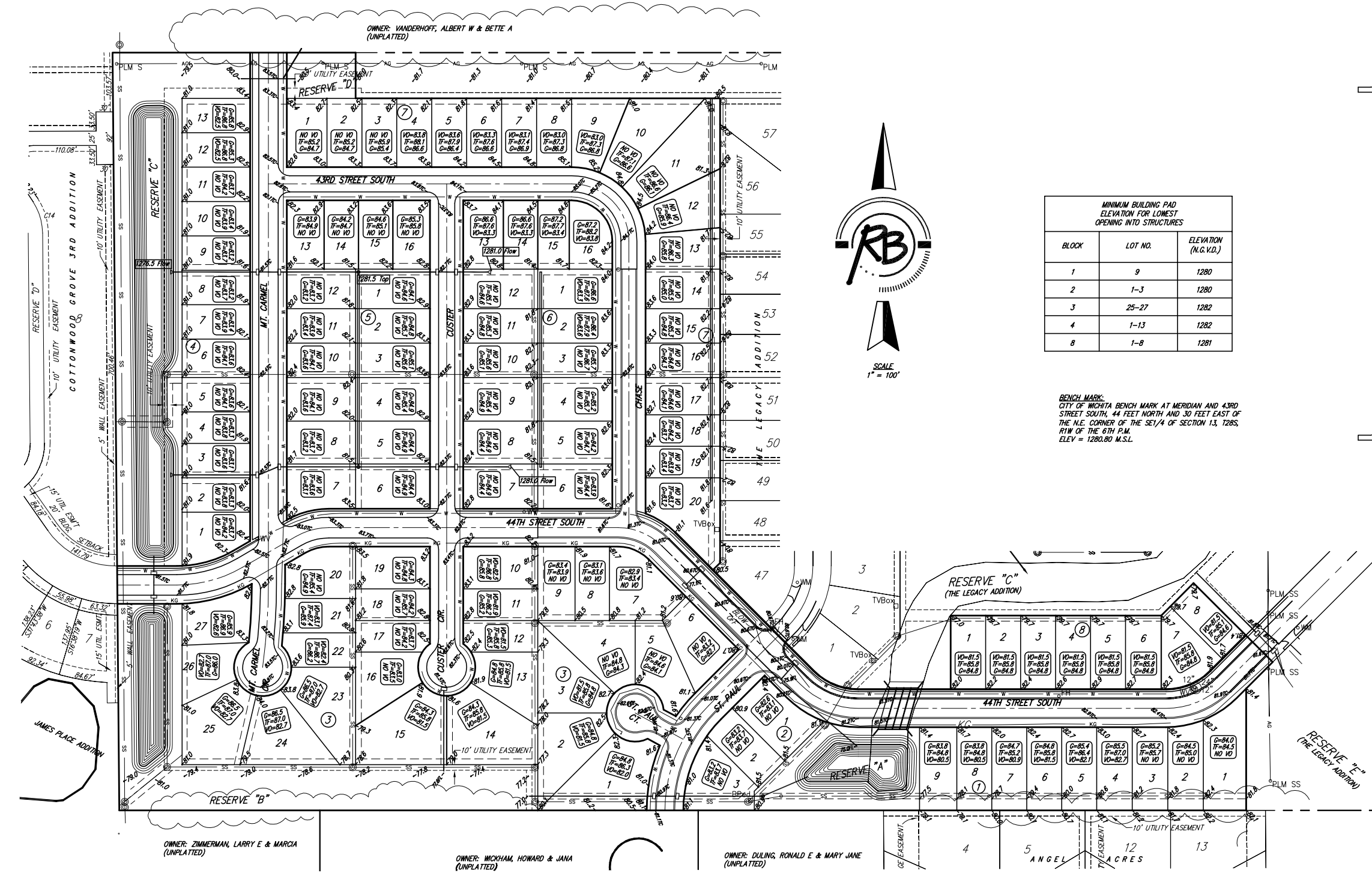

MINIMUM BUILDING PAD ELEVATION FOR LOWEST OPENING INTO STRUCTURES

BLOCK	LOT NO.	ELEVATION (N.G. V.D.)
1	9	1280
2	1-3	1280
3	25-27	1282
4	1-13	1282
8	1-8	1281

BENCH MARK:
CITY OF WICHITA BENCH MARK AT MERIDIAN AND 43RD STREET SOUTH, 44 FEET NORTH AND 30 FEET EAST OF THE N.E. CORNER OF THE SE1/4 OF SECTION 13, T28S, R1W OF THE 6TH P.M. ELEV = 1280.80 M.S.L.

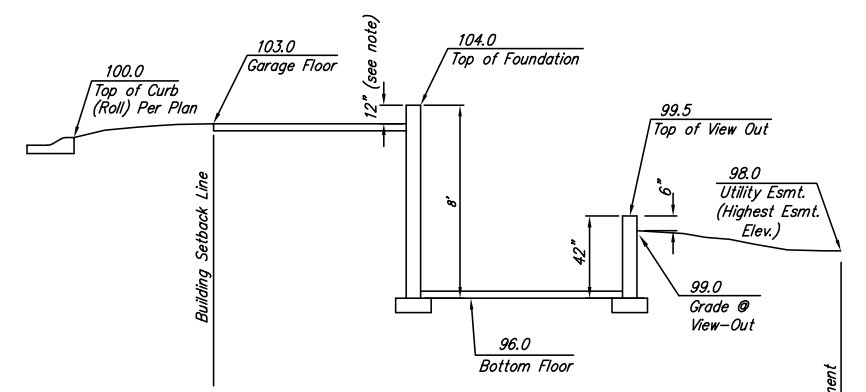

* Varies (Check Individual Lot)
Section Through Typical View-Out Lot

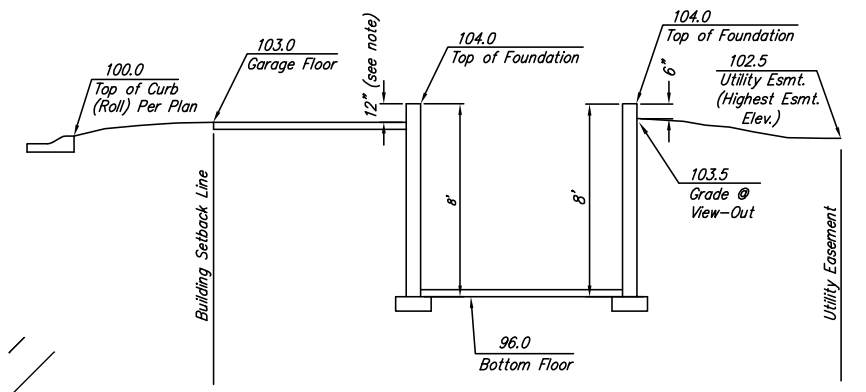

* Varies (Check Individual Lot)
Section Through Typical Full Basement

