

EXPANSION JOINT

NOTE: Extra Thickness to be Subsidiary to Price of Square Yards Pavement

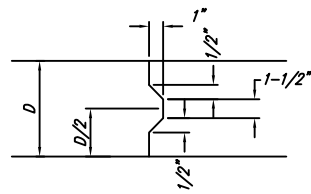

KEYWAY DETAIL

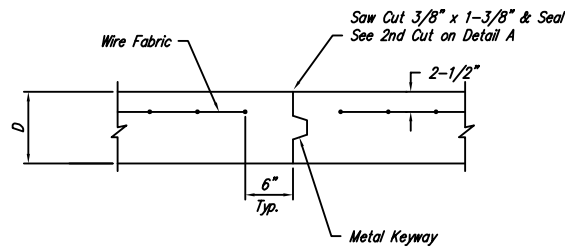

OPTIONAL CONTRACTION JOINT

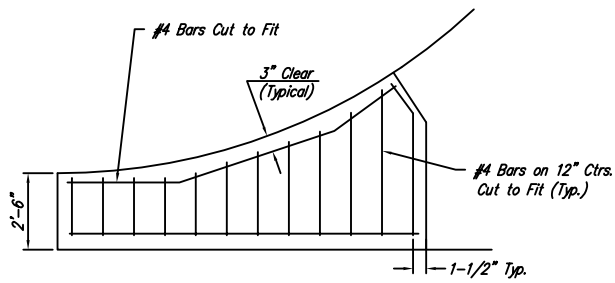

WING REINFORCING DETAIL

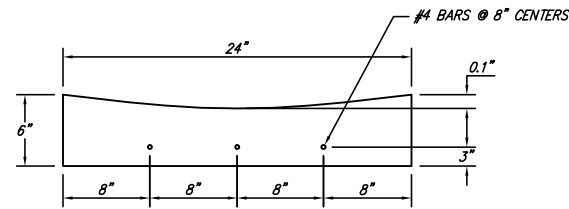

CONCRETE FLUME DETAIL

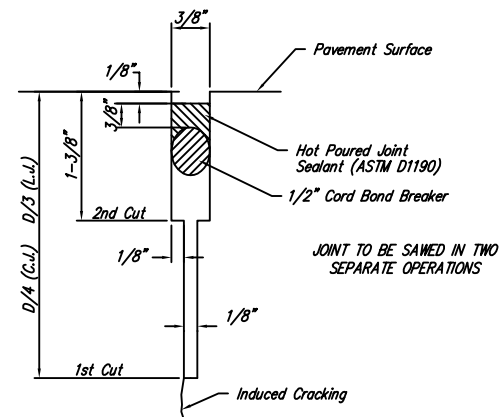

SAW JOINT DETAIL

STANDARD WHEELCHAIR RAMP CONSTRUCTION DETAIL FOR CONCRETE STREETS WITH MONOLITHIC CURB (TYPE A)

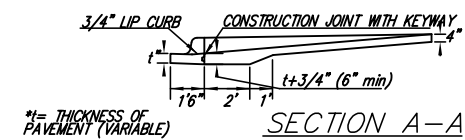
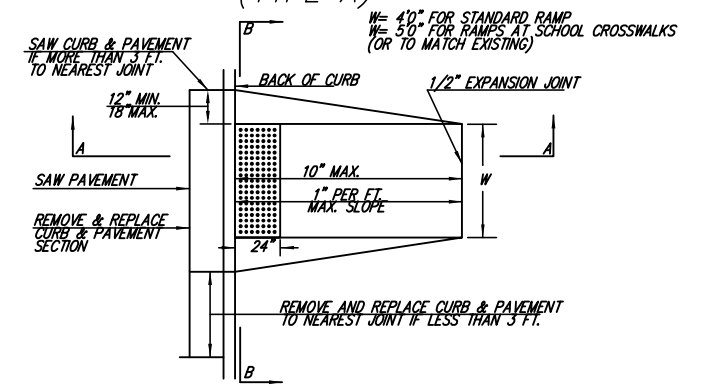

SECTION A-A

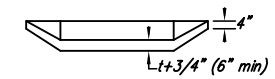

SECTION B-B

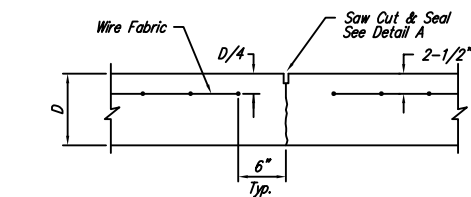

CONTRACTION JOINT DETAIL (C.J.)

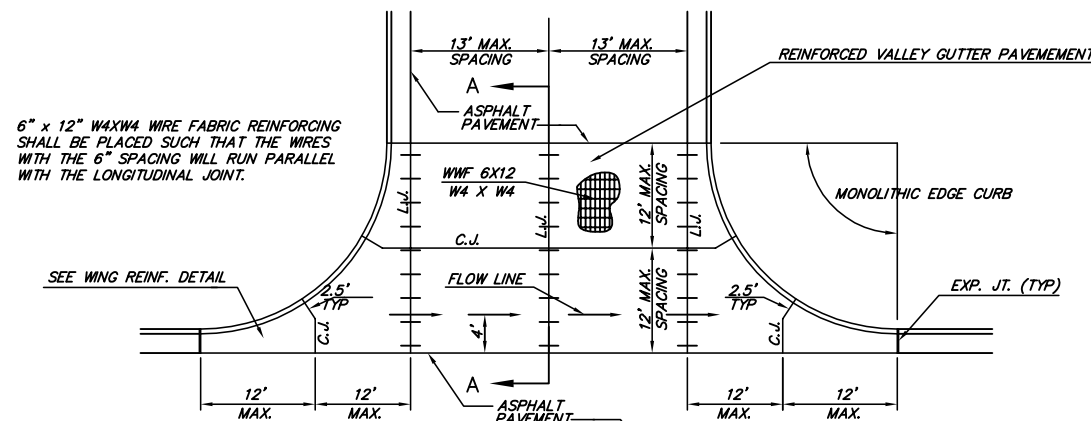

PLAN

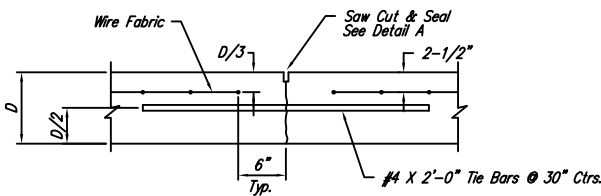

LONGITUDINAL JOINT DETAIL (L.J.)

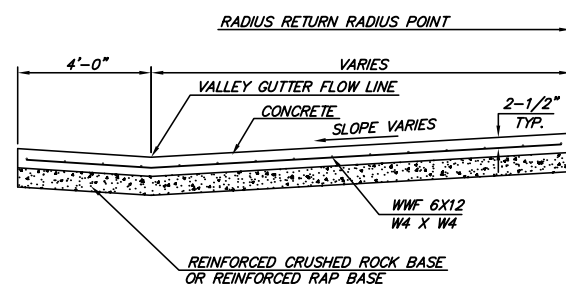

SECTION A-A

REINFORCED VALLEY GUTTER DETAIL

STANDARD WHEELCHAIR RAMP CONSTRUCTION DETAIL FOR STREETS WITH COMBINED CURB & GUTTER (TYPE A)

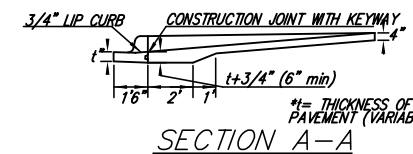
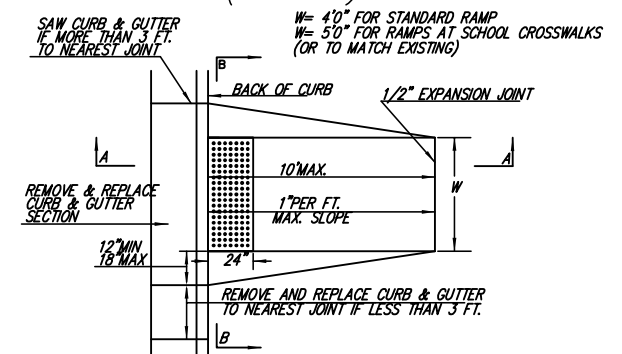

SECTION A-A

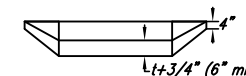

SECTION B-B

OPTIONAL LONGITUDINAL JOINT DETAIL (L.J.)

| | | |
|--|---|-------------------------|
| <p>THE CITY OF WICHITA</p> <p>CITY ENGINEER'S OFFICE CITY HALL - SEVENTH FLOOR 435 NORTH MAIN STREET WICHITA, KANSAS 67202 (316) 268-4201 (316) 268-4114 FAX</p> | <p>VALLEY GUTTER DETAILS</p> <p>WHEELCHAIR RAMP DETAILS</p> | |
| | <p>PROJECT NUMBER 472-84525</p> | <p>OCA # 766136</p> |
| | <p>DATE MAR 96</p> | <p>SHEET 6 OF 43</p> |