

Scale 1" = 10' (Horiz.)

**NOTES**

THE BUILDING PADS SHALL BE AT 1322.00.  
SEE SHEET NO. XX FOR THE PAVEMENT JOINTS.

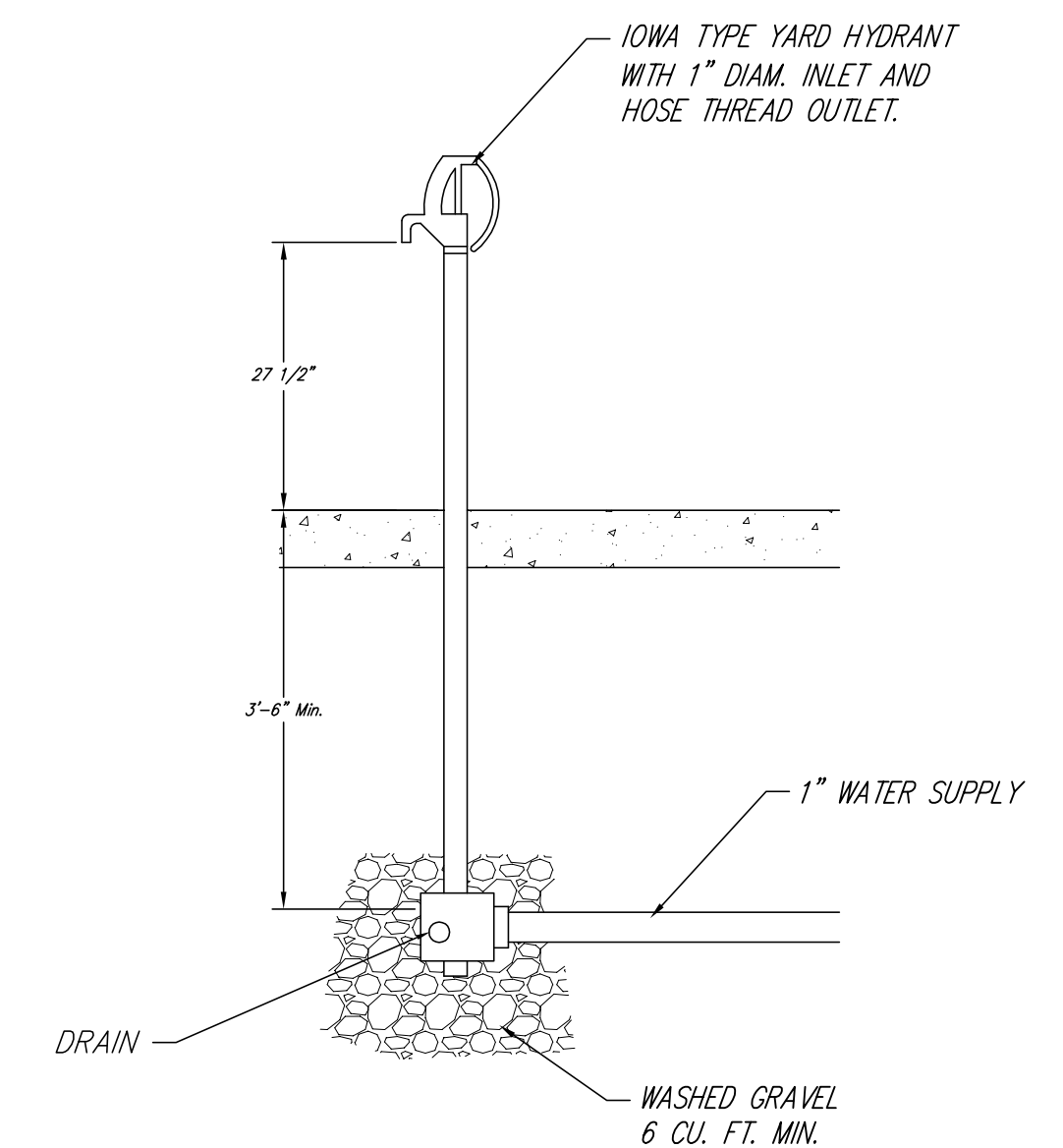
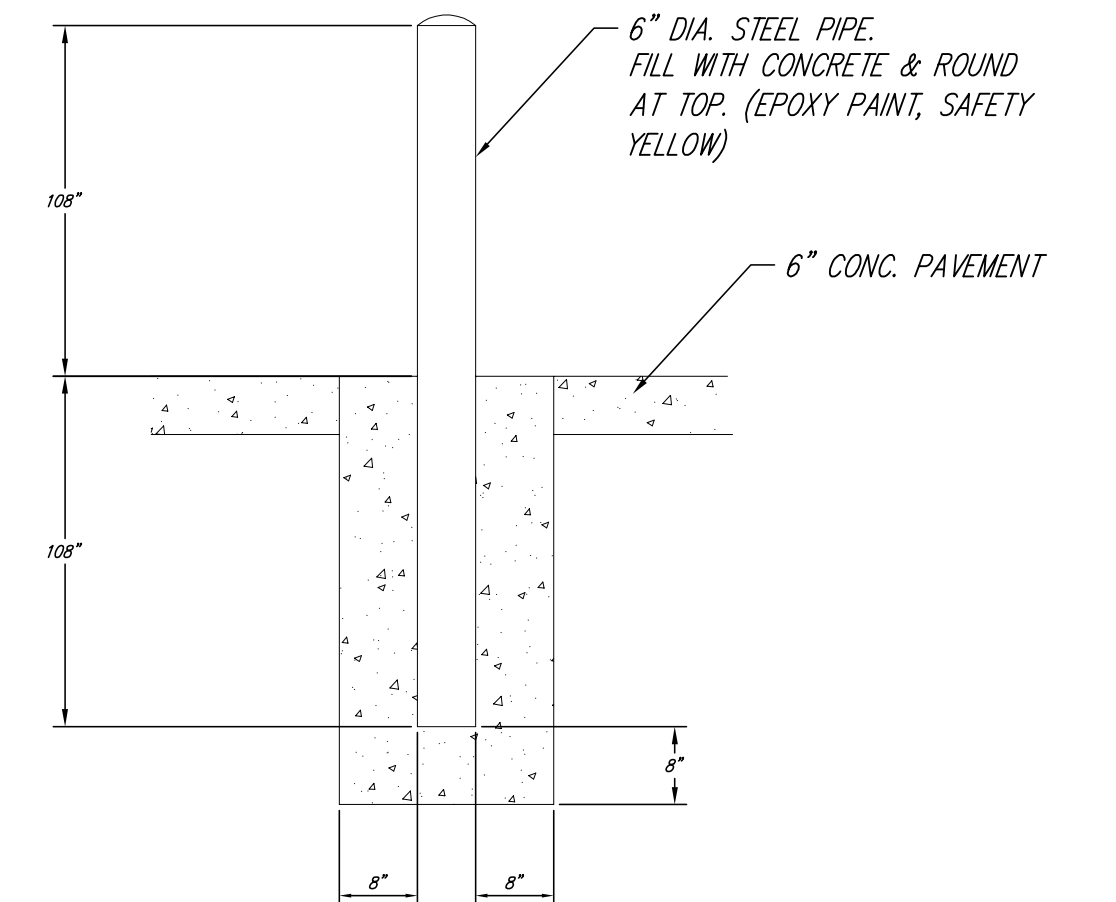
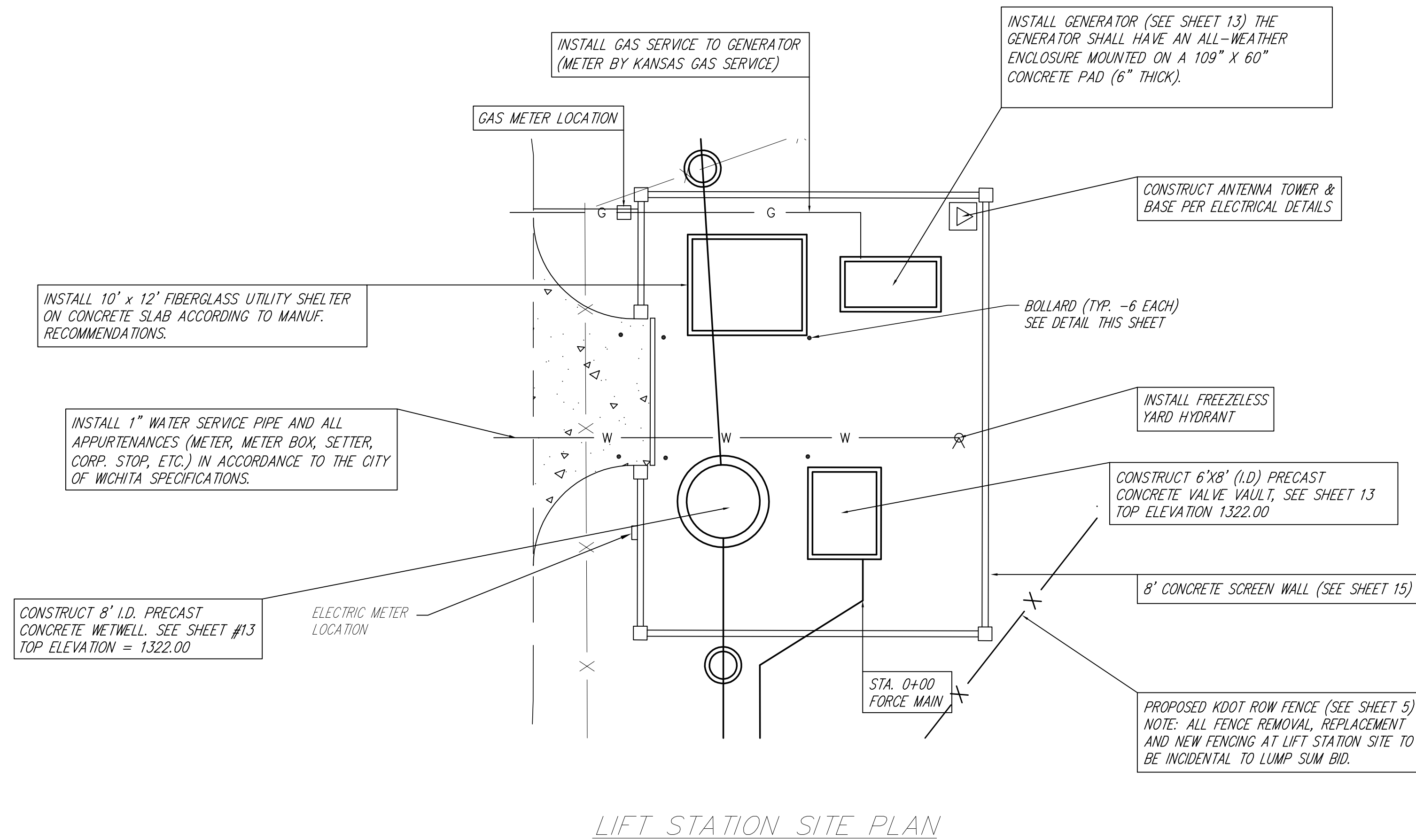

REV. 7-10-07

**MAIN 16, SS #23  
LIFT STATION DETAILS  
CITY OF WICHITA, KANSAS**

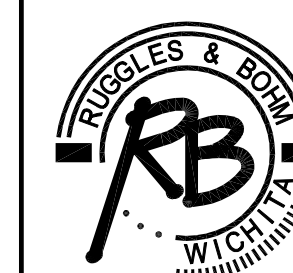

**Ruggles & Bohm, P.A.**  
Engineering, Surveying, Land Planning  
924 North Main (316) 264-8008  
Wichita, Kansas 67203 (316) 264-4621 fax  
www.rbkansas.com E-mail: info@rbkansas.com

DRAWING FILE: KDOT Lift Sta. engg.

PROJECT NUMBER: .

DESIGN	PDC
DRAWN	PDC
REVIEW	
UTILITY	
DATE	Apr. 28, 2006

RB JOB 268X  
SHEET 14 OF 24