

**BANDED SIGN MOUNTING BRACKET DETAIL**

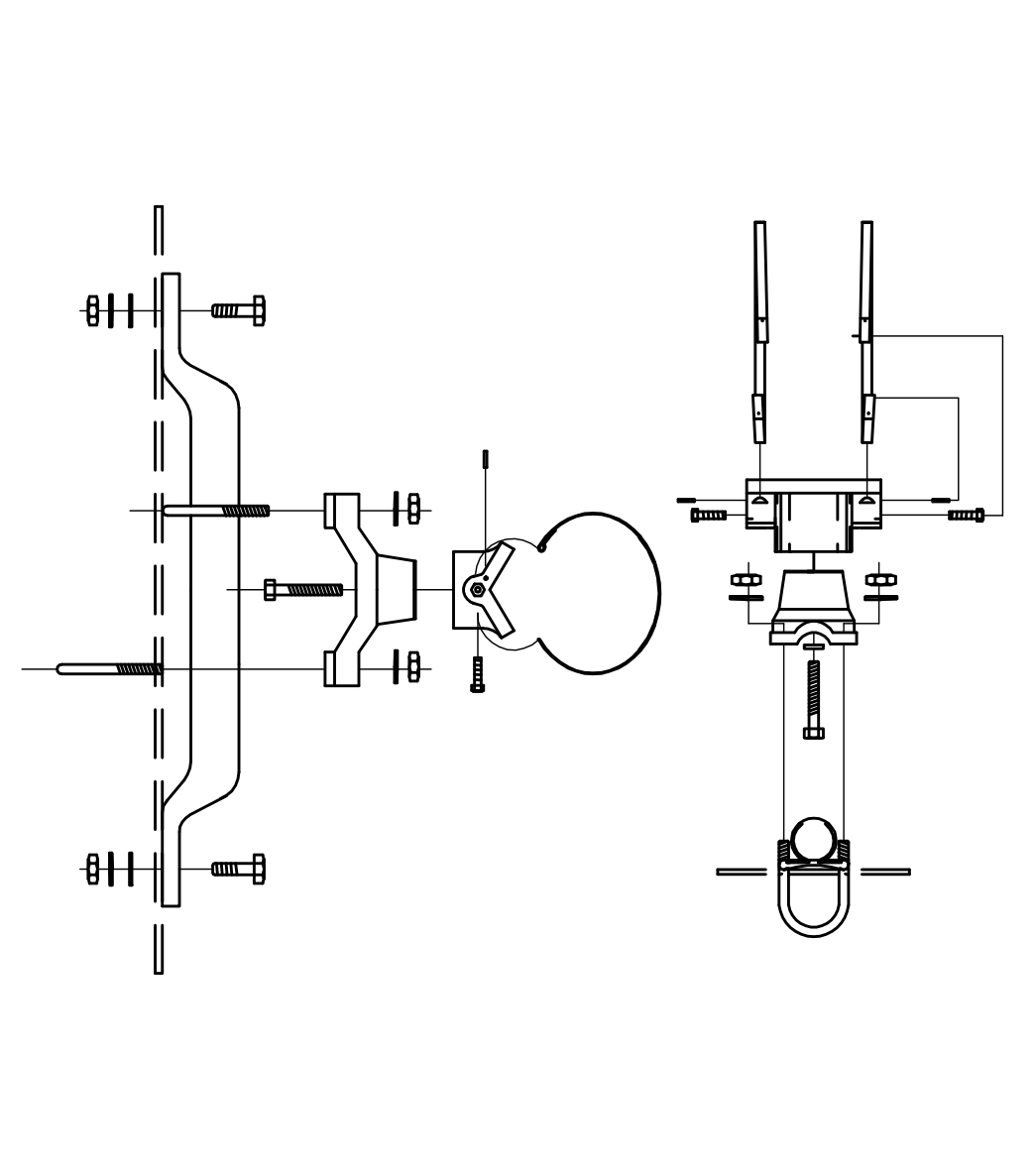

**TYPE I SIGNAL MOUNTING BRACKET ASSEMBLY DETAIL**

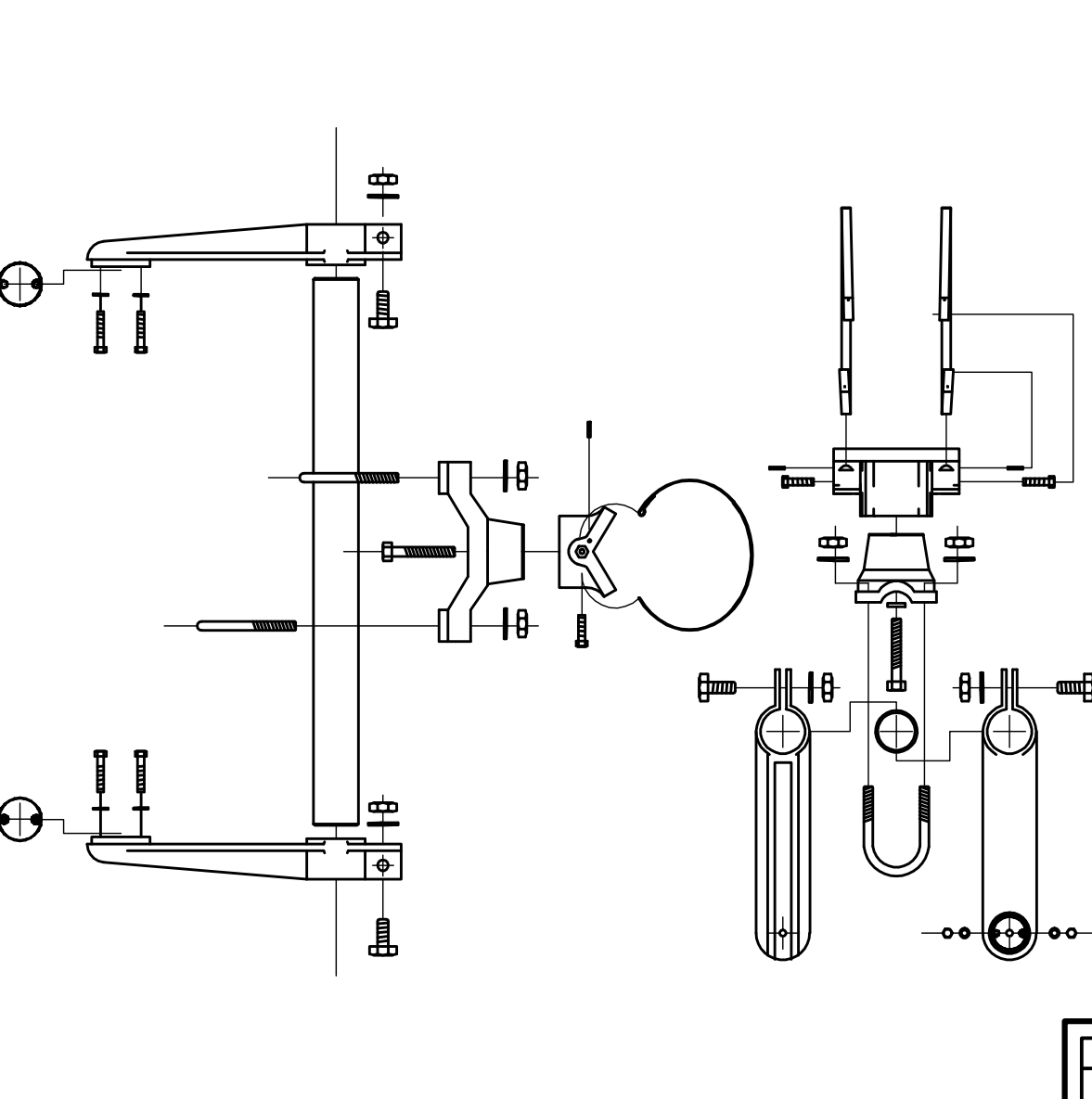

**STANDARD SIGNING**

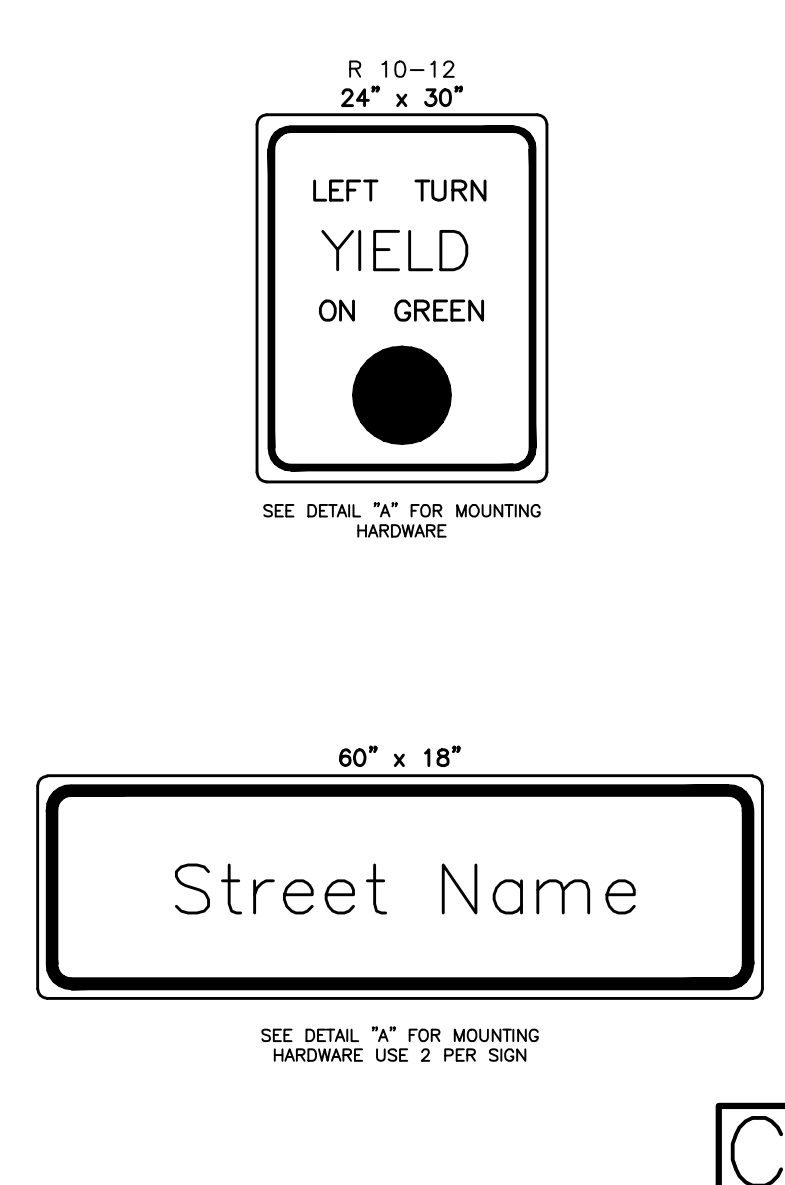

**TYPE III SIDE-OF-POLE MOUNTING BRACKET ASSEMBLY**

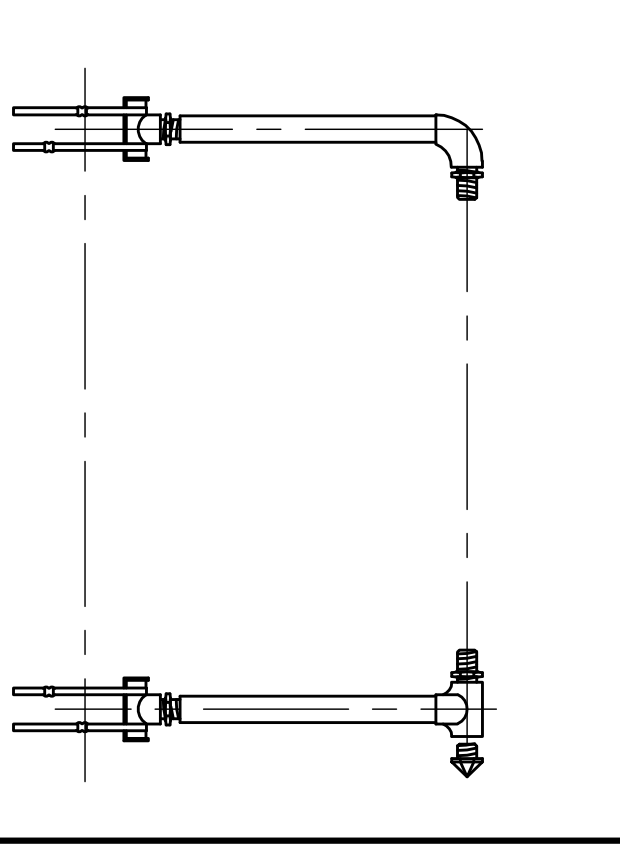

**TYPE II SIGNAL MOUNTING BRACKET ASSEMBLY (SIDE-OF-POLE)**

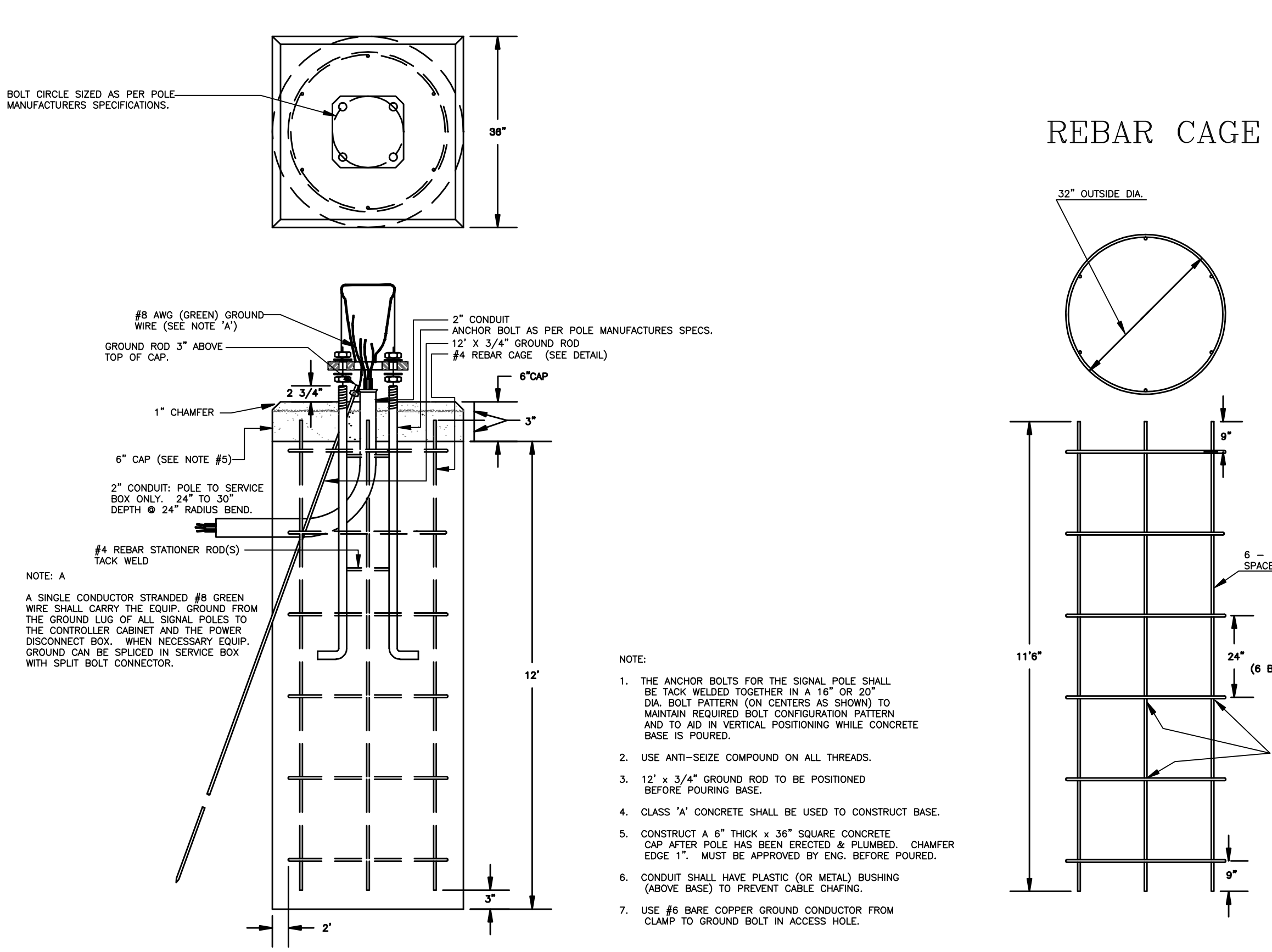
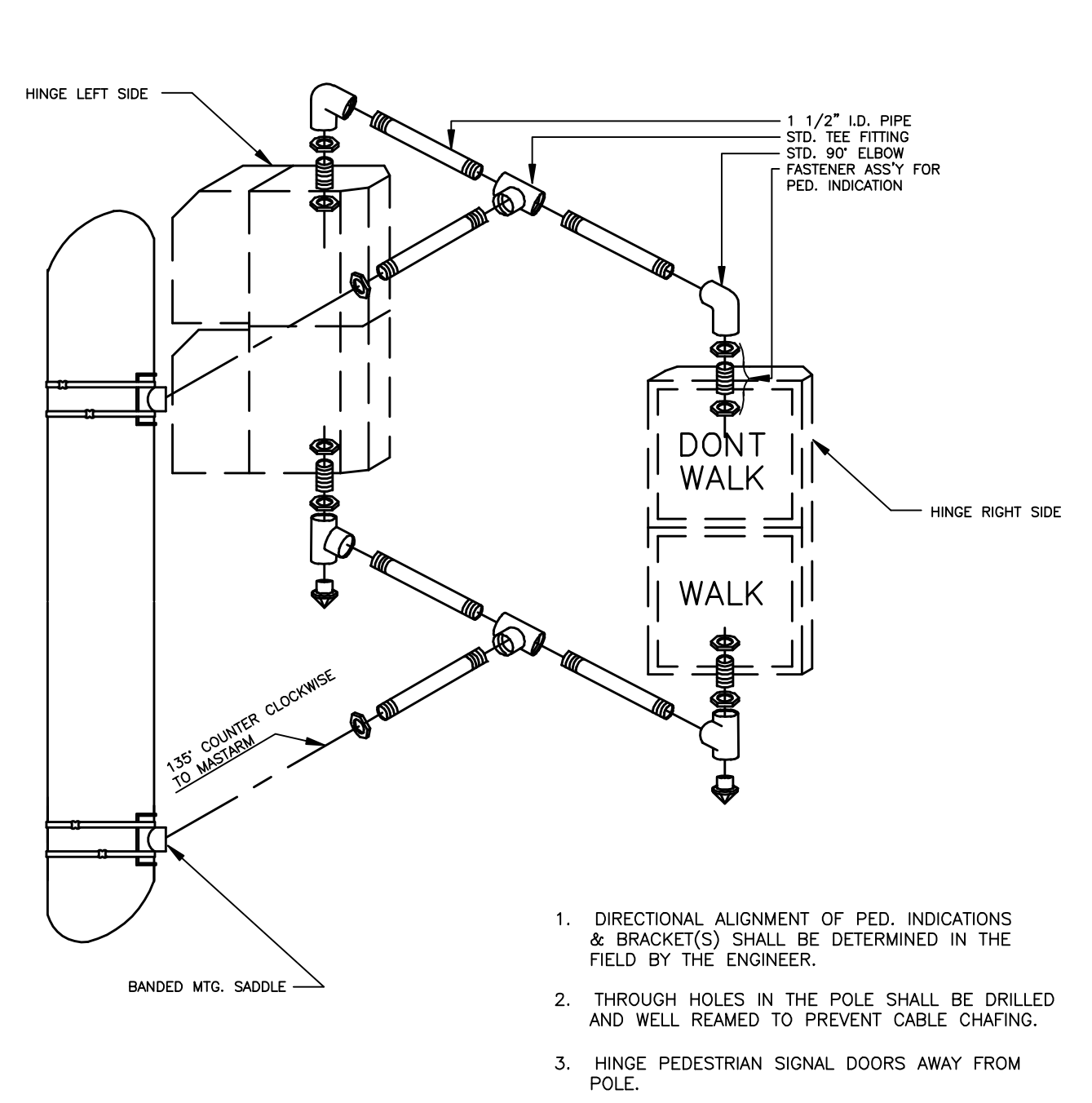

**THE CITY OF WICHITA**

**CITY ENGINEER'S OFFICE**  
CITY HALL - SEVENTH FLOOR  
455 NORTH MAIN STREET  
WICHITA, KANSAS 67202  
(316) 268-4501  
(316) 268-4114 FAX

**STEEL SIGNAL POLE ASSEMBLY DETAILS**

PROJECT NUMBER \_\_\_\_\_ OCA # \_\_\_\_\_

DATE JAN 97 SHEET 45 OF 55