

VALVE VAULT SECTION

NOTES

All items indicated on sheets 8 to 11 shall be incidental to the lump sum bid item for "Lift Station". This includes labor and materials for the installation of all items.

Wet Well

The wet well is a Class 1, Division 1 & 2 environment. This should be taken into account for all electrical requirements per applicable codes. Due to the corrosive atmosphere, all anchors, hardware, assembly bolt sets and brackets must be 304 stainless steel at a minimum. The wet well shall be lined with an approved liner. City of Wichita approved manhole lining systems include: Raven 405 High Build Epoxy, Sauereisen 210S and Zebtron. Products shall be applied at a minimum thickness of 90 mils, or to the minimum thickness required by the manufacturer's specifications, whichever is thicker. Wet Well Access Doors shall be constructed of 1/4" thick aluminum floor plate reinforced to 300 p.s.f. live load. The door shall be equipped with a flush aluminum drop handle that does not protrude above the cover. The door shall be removable for maintenance after construction.

Confined Space Warning Sign

The "Confined Space Warning" sign shall be fastened to the top of all vaults. If necessary for landscaping or site considerations, the sign may be fastened to the vault lid if it does not impede access to the handle. Acceptable materials: Aluminum 73415HH, Plastic 73439HH, or S.A. Vinyl 73463HH.

Vault Construction

The vault shall be poured concrete or approved precast structure (such as Clutter Inc. vaults approved 8/1/2000). The intent of these details shall not be limited by drawings or standards of precast structures. All joints of concrete to concrete or metal to concrete in the construction of the vault shall have an approved water tight mastic joint seal.

The contractor shall provide an outlet flange connection as shown 12-inches from the inside wall. Inlet and outlet wall sleeves shall be provided and installed by the contractor and shall be in alignment with one another. The inlet and outlet pipe shall be ductile iron pipe, cement lined, Class 150 per Standard Specifications and shall be continuous through vault wall and joint no less than two(2) feet from the exterior wall of vault. Flanges of inlet and outlet pipes shall be in proper alignment and bolt pattern shall be rotated in such a way that valves and other fittings shall be in their proper vertical alignment when installed.

The contractor shall install a mega lug, restrained joint, or approved equal on the exterior walls of the vault, which shall be manufactured of ductile iron conforming to ASTM A 536-80, heat treated to a minimum hardness of 370 BHN and have a working pressure of at least 250 P.S.I.

Concrete

All water retaining concrete structures shall conform to ACI 350 "Environmental Engineering Concrete Structures" and be detailed per the "ACI Detailing Manual" Special Publication SP-66. All concrete shall have 4000 PSI minimum compressive strengths at 28 days with a maximum water/cement ratio of 0.45. Minimum cementitious material content shall be 564 lb. per cubic yard. A slump of 1" to 3" shall be provided in the concrete unless an acceptable high-range water reducer is used. Portland cement shall conform to ASTM C-150, Type II. All aggregate for normal weight concrete shall meet ASTM C33. Aggregates shall be proportioned such that mix design shall contain a minimum of 50% coarse aggregates by gradation requirements set forth in ASTM C33. Coarse aggregate shall meet No. 67 grading requirements. Concrete shall have from 4 to 7% entrained air, conforming to ASTM C 260. concrete shall be in strict conformance with the current "ACI Manual of Concrete Practice". Chamfer all exposed edges of concrete 3/4", unless noted otherwise. Special care should be provided for the formwork of watertight structures with form ties having waterstops. Formwork shall comply to the ACI 347 "Guide to Formwork for Concrete". Concrete joints shall occur at locations shown on the drawings. Waterstops shall be Polyvinyl Chloride with a 3/8" minimum thickness and have a minimum width of 6" Adhesive waterstops, where noted on the drawings shall be Greenstreak "HydroTite" or approved equal. Placement of concrete shall be in conformance with ACI 304R. Special corner bar configuration is needed at watertight construction, see drawings for details.

Flowmeter

Flowmeter shall be magnetic type as approved by City of Wichita Specifications. A NEMA 4X Junction Box shall be provided inside flowmeter manhole. Liquid tight, flexible conduit shall be used in manhole.

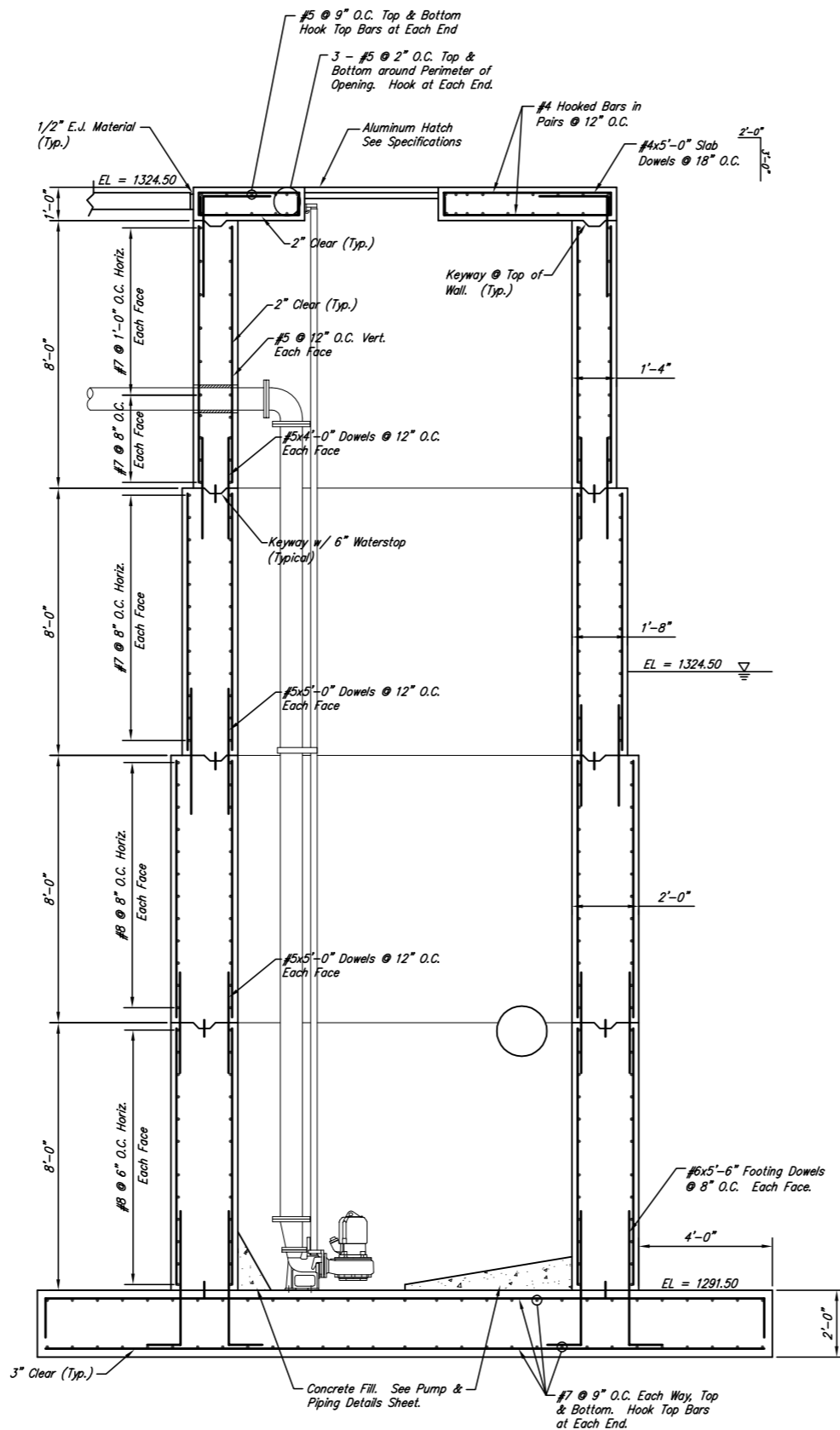

WET WELL SECTION

Reinforcing Steel

All mesh shall meet ASTM A 185 and be furnished in flat sheets. Lap a minimum of 6" or one full mesh, whichever is greater. All mesh shall be placed on SBP's at 48" O.C., Max. All reinforcing shall meet ASTM A615-60,000. Reinforcing shall be detailed according to the ACI detailing manual under the supervision of a Structural Engineer licensed in the state where the project is located. Reinforcing shall be fabricated and placed per ACI and CRSI accepted methods, including concrete cover and bar supports. Provide 3" slab bolster with continuous bottom plate at 4'-0" maximum centers for positioning all footing bars cast against soil. All reinforcing steel for concrete exposed to view shall supports with plastic coated feet. Mark each bundle of reinforcing with weatherproof tags.

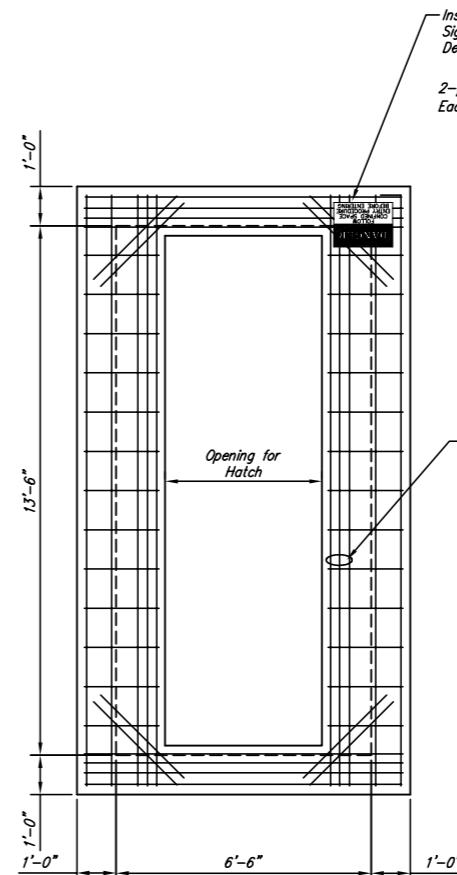

VALVE VAULT SLAB REINFORCEMENT PLAN

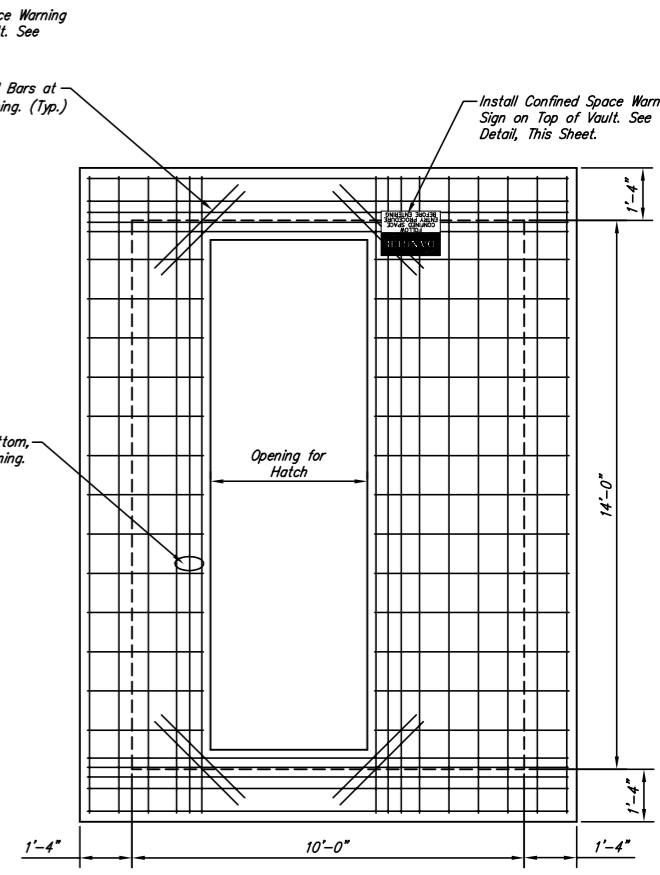

WET WELL SLAB REINFORCEMENT PLAN

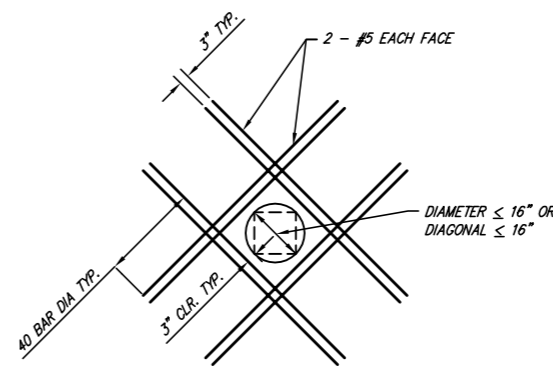

NOTE: EXTRA BARS ARE NOT REQUIRED AT CIRCULAR OR RECTANGULAR OPENINGS WHEN DIAMETER OR DIAGONAL IS LESS THAN 8" AND REINF. IS NOT CUT.

TYPICAL OPENING BAR DETAILS

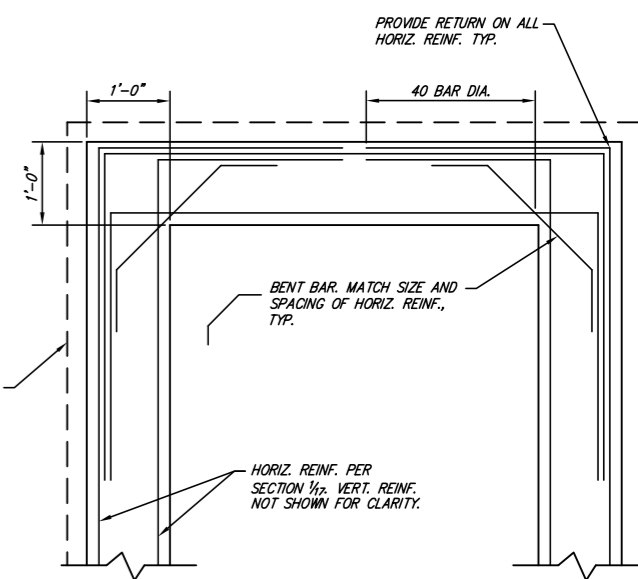

TYPICAL CORNER DETAIL

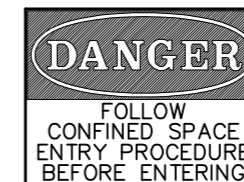

CONFINED SPACE SIGN DETAIL

MAIN 23, SW INTERCEPTOR SEWER
PUMP STATION REINFORCING PLAN
WICHITA, SEDGWICK COUNTY, KANSAS

Ruggles & Bohm, P.A.
Engineering, Surveying, Land Planning
924 North Main
Wichita, Kansas 67203
www.rbkansas.com
(316) 264-8008
(316) 264-4621 fax
E-mail: info@rbkansas.com

DESIGN	KWL	10 of 16			
DRAWN	KWL				
REVIEW					
UTILITY					
DRAWING FILE	lift station	PROJECT NUMBER	468-84141	DATE	July 12, 2006