

**GossonLivingston**

Architecture  
420 South Emporia  
Wichita, KS 67202  
Tel: (316) 265-9387  
Fax: (316) 265-5646  
Email: architecture@gl.com

© 2007 Gosson Livingston Associates, Inc.

The drawing and all information herein is the exclusive property of Gosson Livingston Associates, Inc. and is not to be copied or used in any way without the express written consent of Gosson Livingston Associates, Inc. All drawings, specifications, ideas, designs and arrangements appearing herein constitute the original and unpublished work of:  
Gosson Livingston Associates, Inc.



Johnson & Associates, Inc.

100 E. California Ave. - Third Floor

Oklahoma City, OK 73104

(405) 235-8075 FAX (405) 235-8078

Certificate of Authorization #E-1128 EXP. DATE: 12-31-2008



**WATERWALK**

**PUBLIC IMPROVEMENTS PHASE 2 PACKAGE 3**

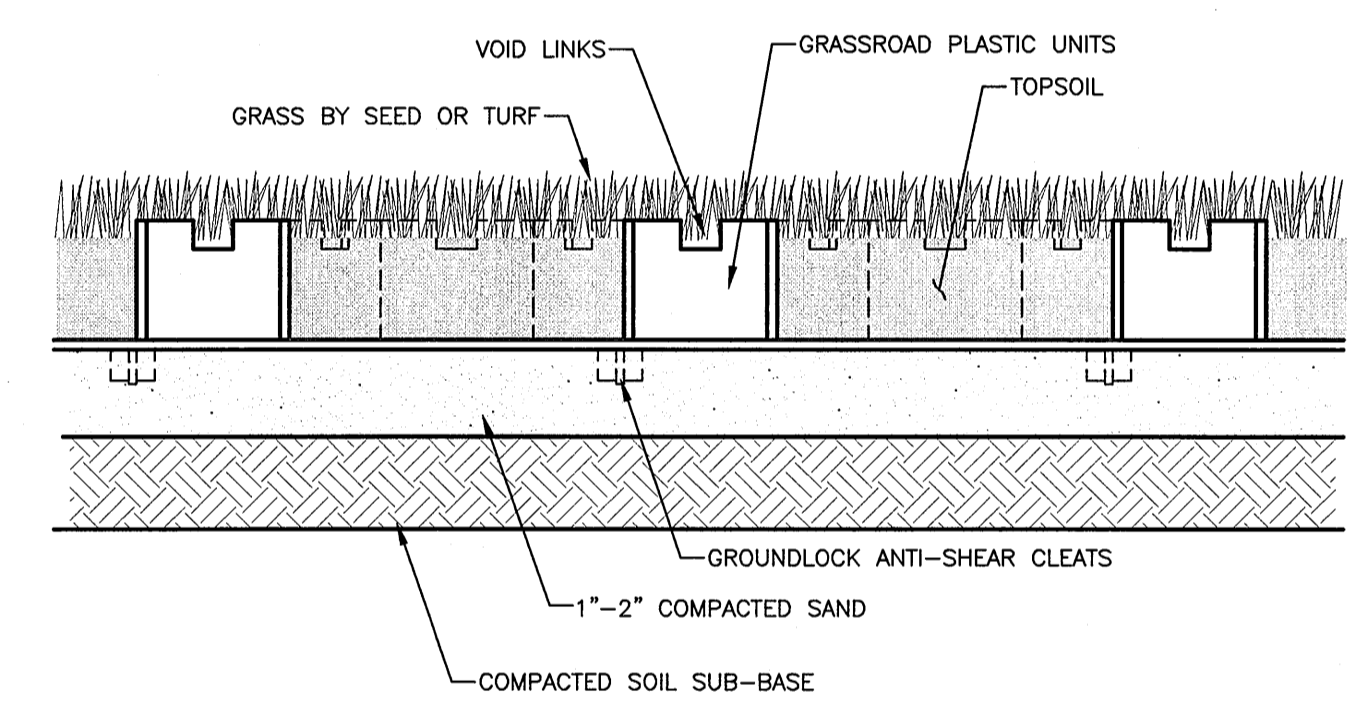
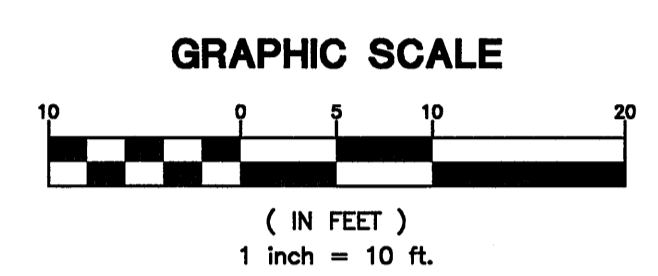
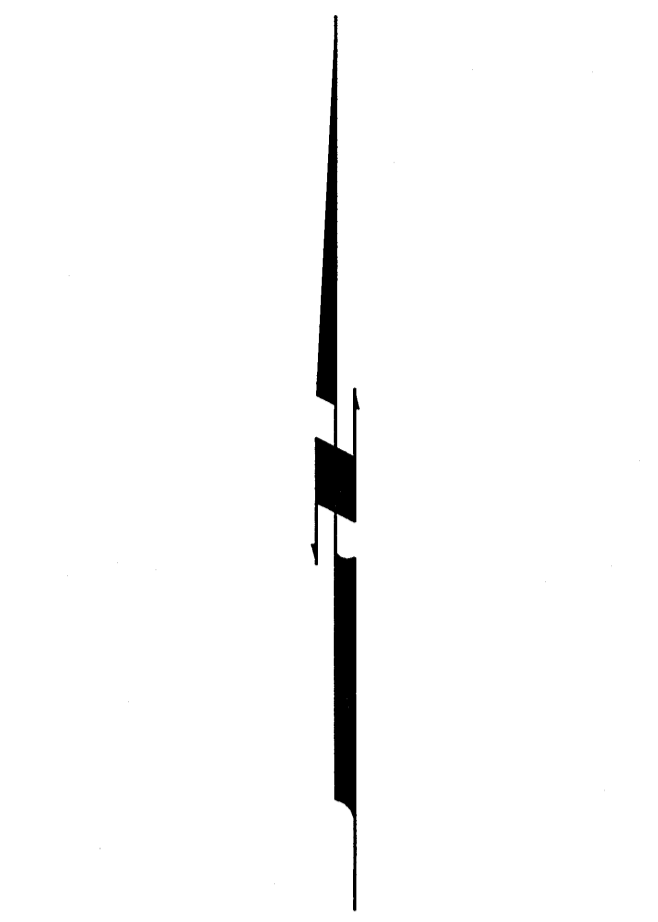
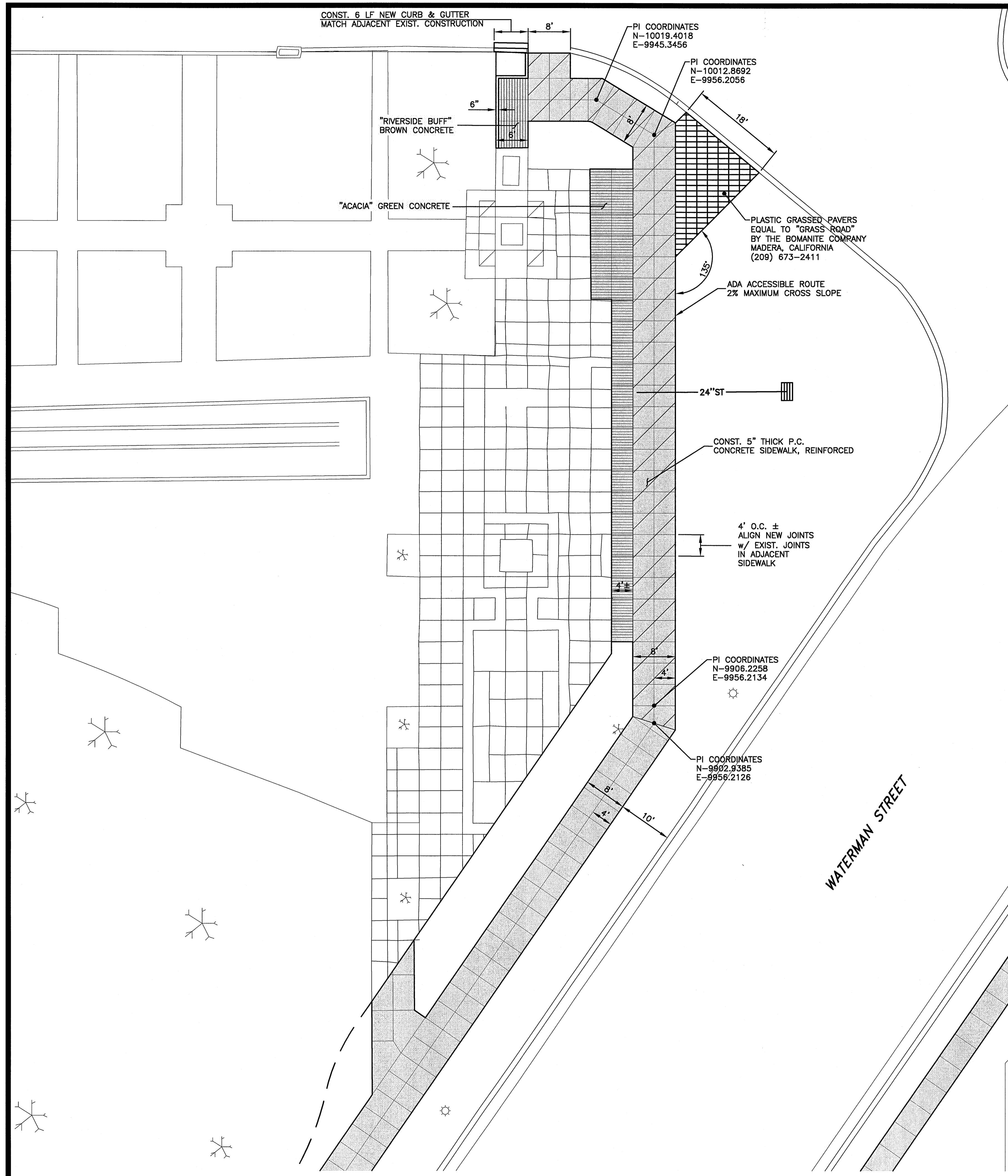

**PLASTIC GRASSED PAVERS DETAIL**  
SCALE: NTS

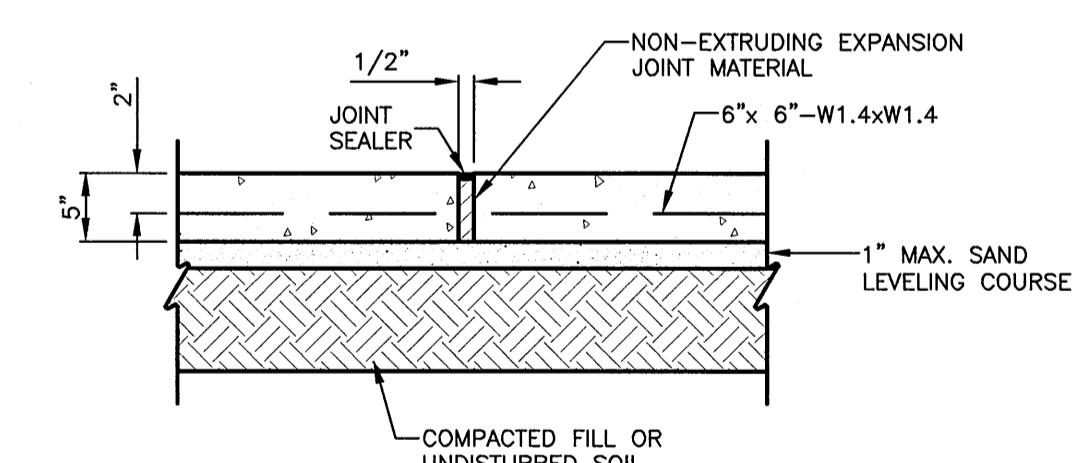

**EXPANSION JOINT**

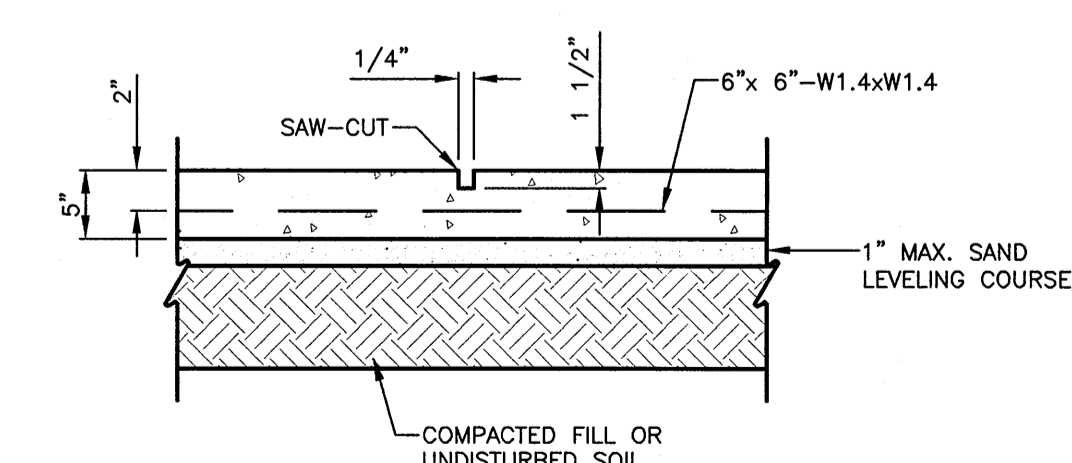

**CONTROL JOINT**

CONCRETE WALK JOINT SPACING		
CONTRACTION JOINTS	EXPANSION JOINTS	
WIDTH	TRAVERSE	JOINTS
4'	4'±	40' MAX.
6'	6'	42' MAX.
8'	4'	40' MAX.
10'	5'	40' MAX.
12'	6'	42' MAX.

**5\"/>**

12/12/2007 4:46 PM Job: C:\21215016 Pkg3\Phase2\1016-1016-1016-1016.dwg

Mark	Date	Description
	11/16/07	BID SET
	4/25/07	FIELD CHECK SET

**LAYOUT PLAN**

Job No.		<b>HW2.3</b> OF <b>3</b> 29 of 44
Date	12-17-07	
Drawn	B.C.	
Checked	P.B.	