

TYPICAL SECTION

- ① Saw cut, remove and replace surface course as necessary to provide a neat line. This work to be *Subsidiary* to Asphalt Pavement.
- ② See Spot Elevations.
- ③ Bituminous Base Removal to be *Subsidiary* to "Combined Curb & Gutter Removed".
- ④ Excavation calculated from existing ground to this line. No Deduction made to excavation quantity for curb & gutter to be removed.

GENERAL NOTES

FABRIC BASE REINFORCEMENT SHALL BE BX 1100 GEOGRID AS MANUFACTURED BY TENSAR CORPORATION OR APPROVED EQUAL. FABRIC BASE REINFORCEMENT SHALL BE INSTALLED IN ACCORDANCE WITH MANUFACTURER'S RECOMMENDATIONS.

ROCK BASE IS TO BE COMPACTED AND SMOOTHED WITH A STEEL FACED ROLLER (PLATE VIBRATOR IN NARROW AREAS) PRIOR TO PLACEMENT OF ASPHALT. TACK COAT WILL NOT BE APPLIED TO TOCK BASE.

A TACK COAT OF EMULSIFIED ASPHALT (SC-1H OR CSS-1H) SHALL BE APPLIED AT AN APPROXIMATE RATE OF 0.05 GALLONS PER SQUARE YARD BETWEEN EACH LIFT OF ASPHALTIC MATERIAL.

BITUMINOUS BASE AND ASPHALTIC CONCRETE WEARING SURFACE SHALL BE PLACED WITH A LAYDOWN MACHINE HAVING AUTOMATIC CONTROLS FOR LINE AND GRADE.

CONSTRUCTION JOINTS IN EACH LIFT SHALL BE STAGGERED A MINIMUM DISTANCE OF ONE (1) FOOT FROM JOINTS IN PRECEDING LIFTS AND PLACED SO THAT A JOINT WILL BE CONSTRUCTED ON THE CENTERLINE OF THE TOP LIFT.

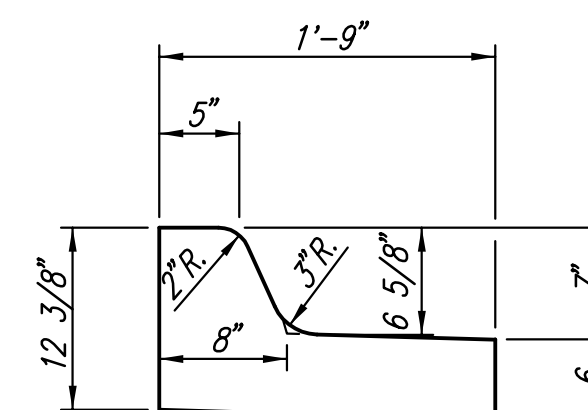

MEDIAN COMBINED CURB & GUTTER
(6 5/8")

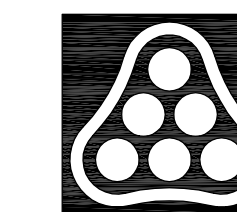

No.	Revision	By	Date
CROSS POINTE 2ND ADDITION-PHASE 1 21ST ST. N. LEFT TURN LANE TYPICAL SECTION JAMES L. ARMOUR, P.E. - CITY ENGINEER CITY OF WICHITA PROJECT NO. 472-84234 Professional Engineering Consultants, P.A. 303 S. TOPEKA • WICHITA, KANSAS 67202 316-262-2691 • FAX 316-262-3003			
Designed by	BDB, BMM	Job No.	35-07293-003
Drawn by	BJS, TAT	Date	October 2007
			Sheet 4 of 9