

EXPANSION JOINT

NOTE: Extra Thickness to be Subsidiary to Price of Square Yards Pavement

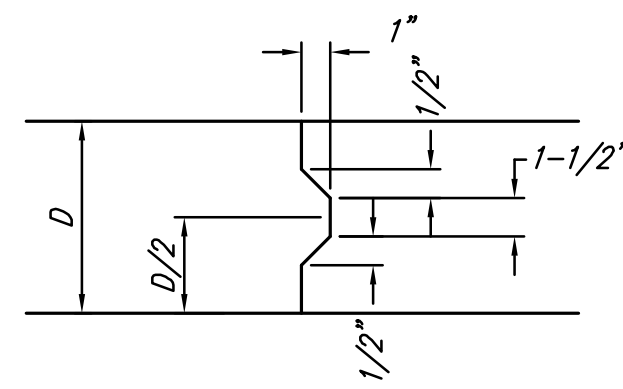

KEYWAY DETAIL

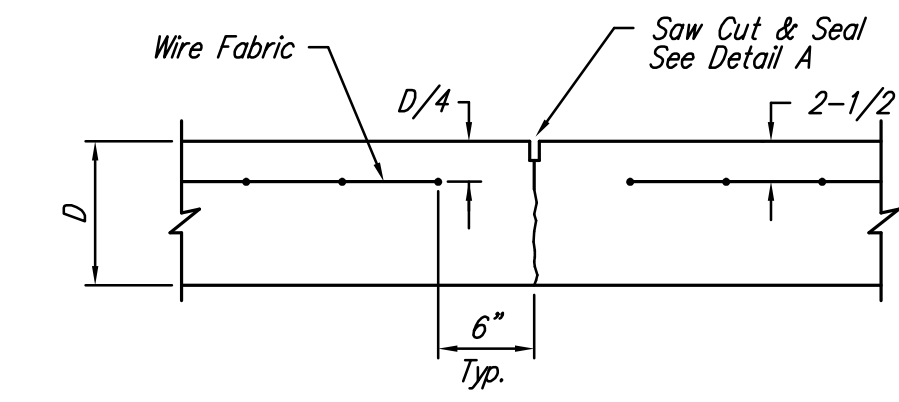

CONTRACTION JOINT DETAIL (C.J.)

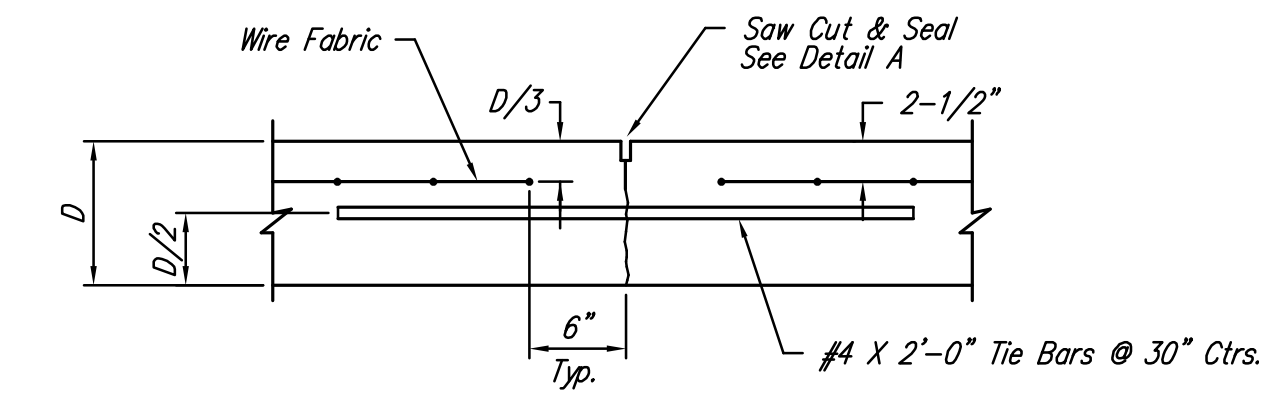

LONGITUDINAL JOINT DETAIL (L.J.)

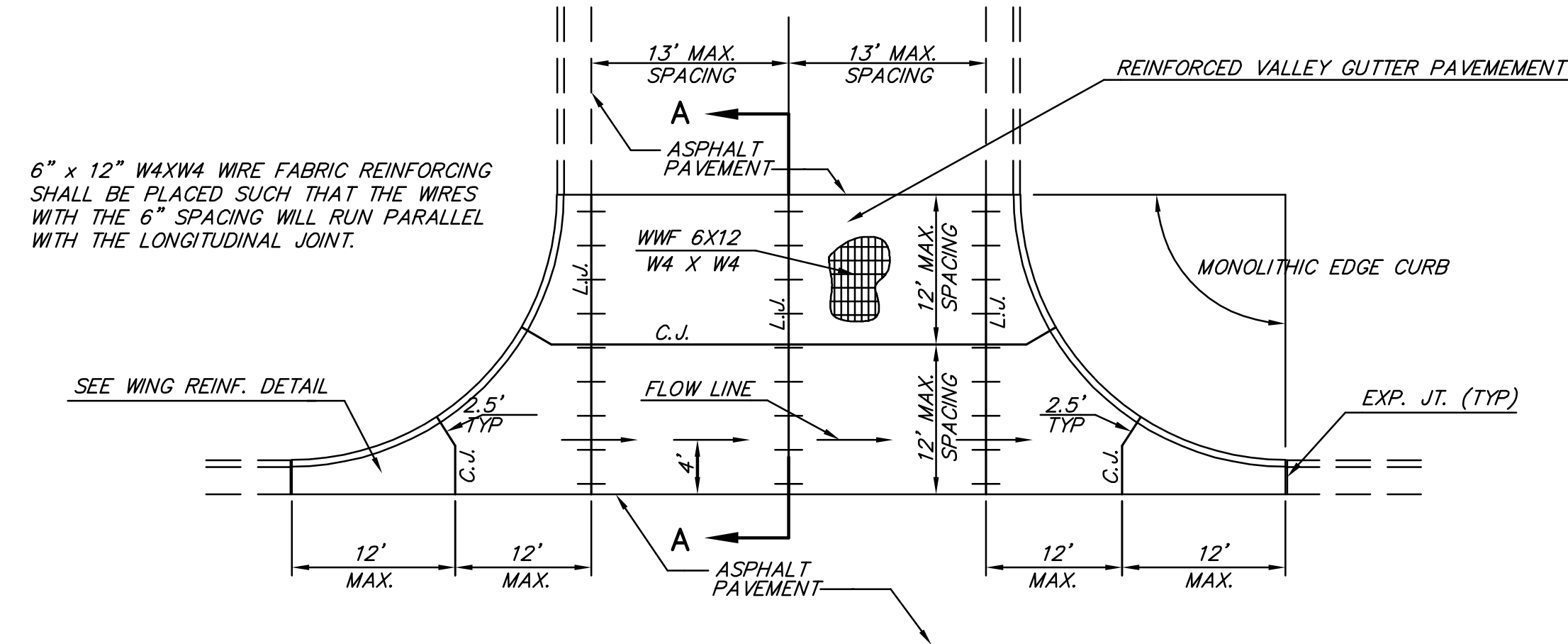

PLAN

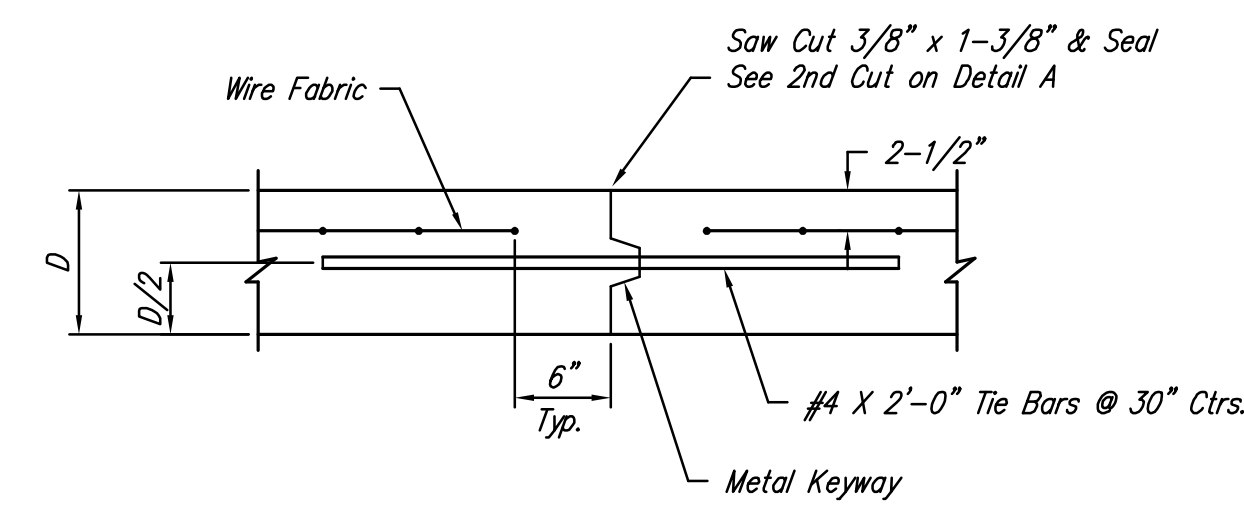

OPTIONAL CONTRACTION JOINT

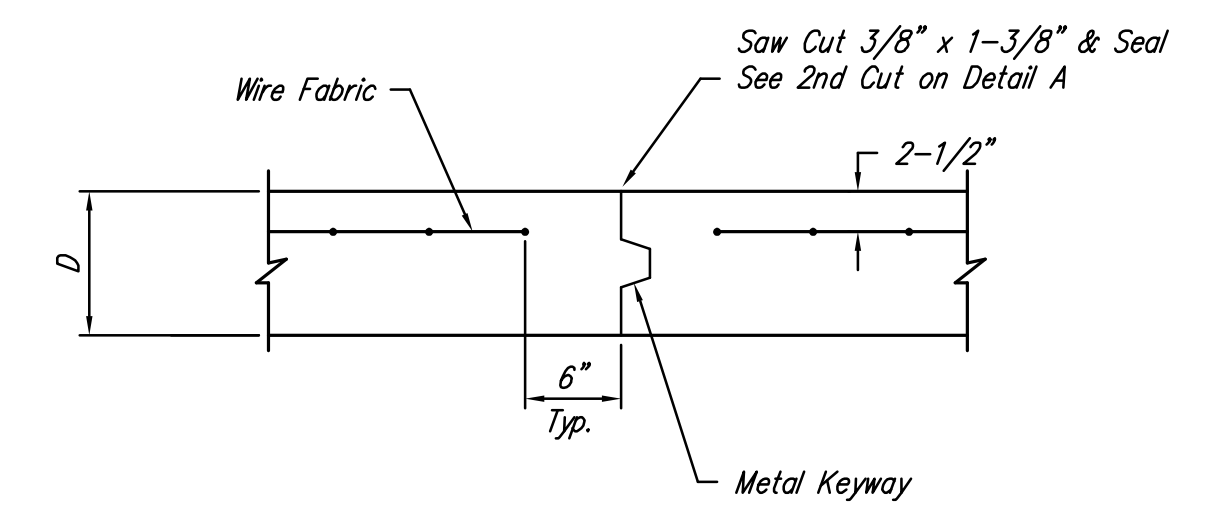

OPTIONAL LONGITUDINAL JOINT DETAIL (L.J.)

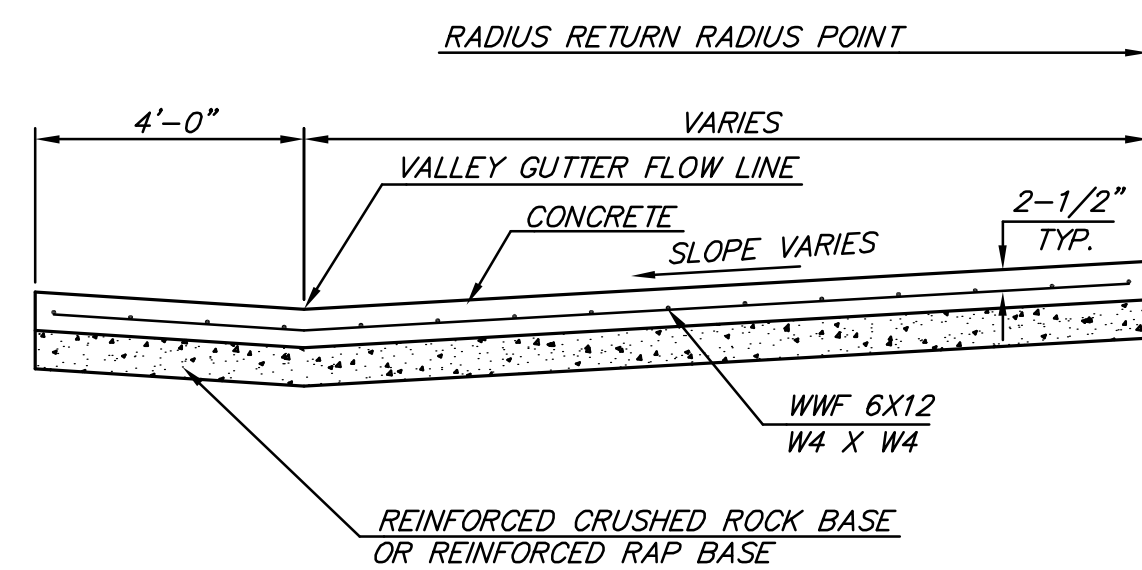

SECTION A-A

REINFORCED VALLEY GUTTER DETAIL

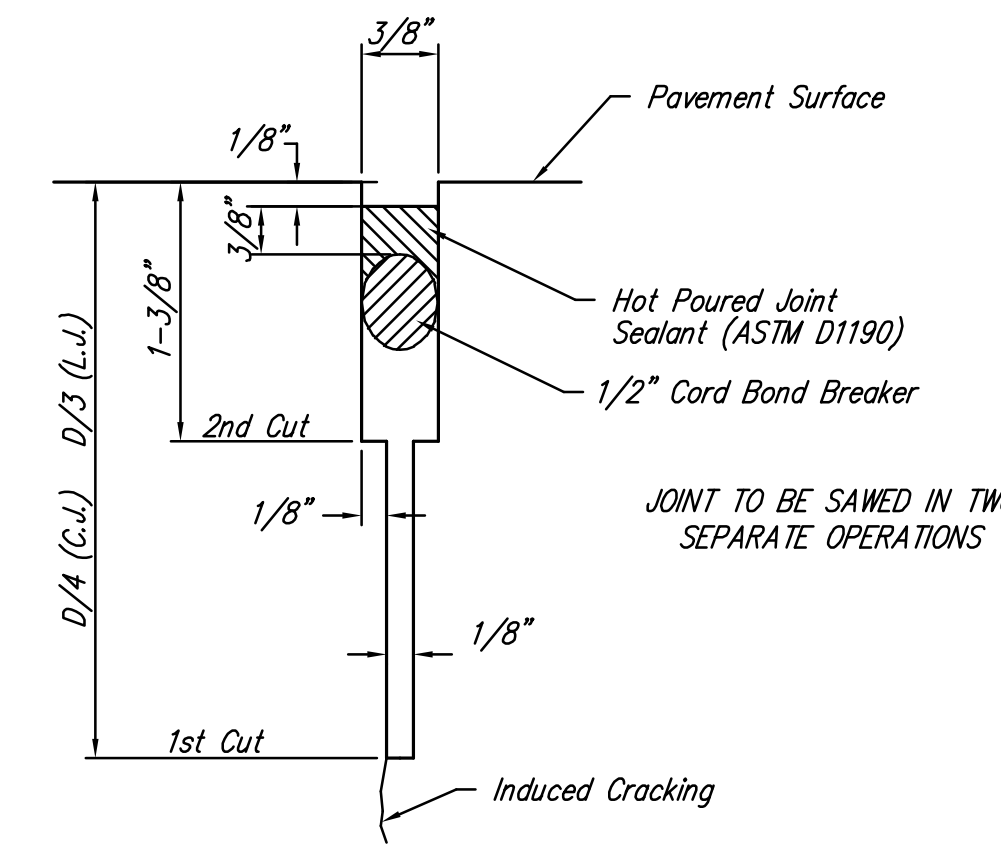

SAW JOINT DETAIL

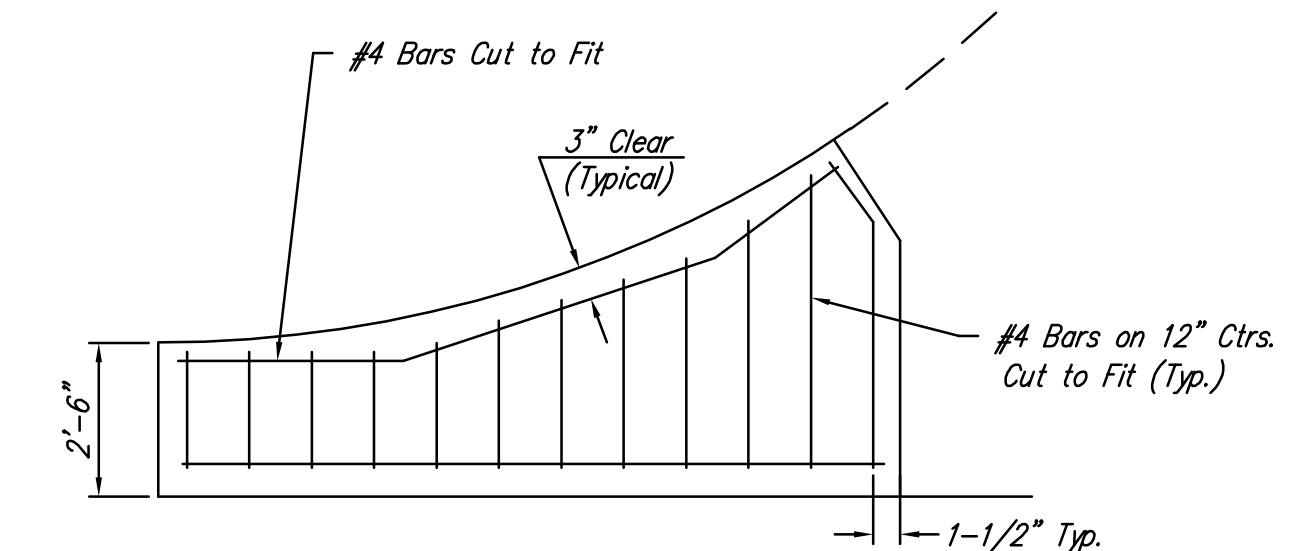

WING REINFORCING DETAIL

<p>THE CITY OF WICHITA</p> <p>CITY ENGINEER'S OFFICE CITY HALL - SEVENTH FLOOR 455 NORTH MAIN STREET WICHITA, KANSAS 67202 (316) 268-4501 (316) 268-4114 FAX</p>	VALLEY GUTTER DETAILS	
	JAMES L. ARMOUR, P.E. - CITY ENGINEER	
	PROJECT NUMBER 472-84598	OCA NUMBER 766181
	DATE Nov 2007	Sheet 4 of 23

J:\CIVIL\062665\DWG\PAV\ENTRY\06266_ED3.DWG