

127th Street East

Maintain Current Grade Through this Area

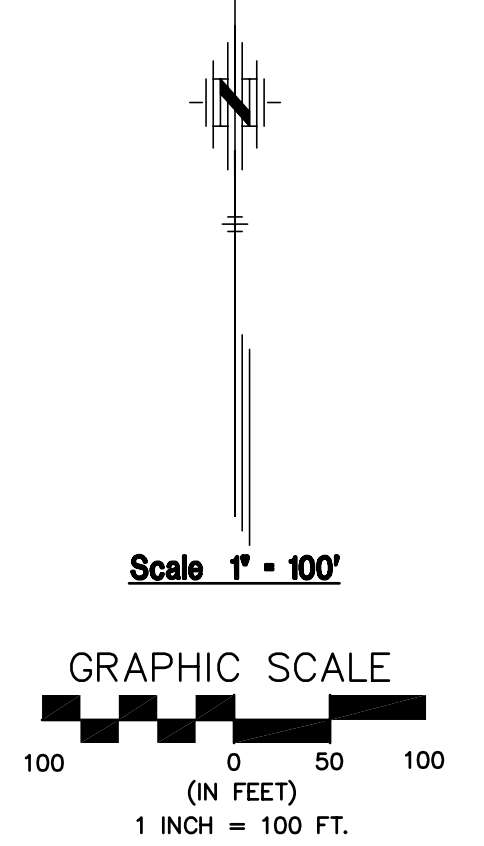

- LEGEND**
- 20.9 = Proposed Elevation at Lot Corner
 - X 28.8 = Proposed Finished Elevation at 'X'
 - = Direction of Flow

- NOTES:**
1. Contractor shall grade all right-of-way areas according to elevations shown. (Cost subsidiary to Site Clearing/Restoration.)
 2. Contractor shall waste earthwork evenly across low lying lots. (Cost subsidiary to Site Clearing/Restoration.)

Limits of Grading

Revision					
Approved	By	Date	No.	Date	No.
Approved	By	Date	No.	Date	No.
<p>EQUESTRIAN ESTATES ADDITION - PHASE 2 STORM WATER DRAIN NO. 179 LOT GRADING PLAN CITY OF WICHITA, KANSAS JAMES L. ARMOUR, P.E. - CITY ENGINEER C.O.M. Project # 48-83319 O.C.A. # 751410</p>					
<p>POE & ASSOCIATES, INC. CONSULTING ENGINEERS 5940 E. Central, Suite 200 ■ Wichita, KS 67208-4242 Phone 316/685-4114 ■ FAX 316/685-4444</p>					
<p>FINAL</p>					
<p>Designed By: JMU/JPD Drawn By: JMU/JPD P.O. Job No.: 1694J Date: January 2006</p>					
<p>Sheet 9 of 11</p>					