

NW Corner, NW1/4
Section 35-27-2E
Found 3/4" Pipe

NE Corner, NW1/4
Section 35-27-2E
Found 3/4" Pipe

CURVE	LENGTH	RADIUS	TANGENT	CHORD	BEARING	DELTA
C1	215.00	50.00	76.45	83.69	S33°49'50"W	246°22'28"
C2	86.72	150.00	44.61	85.52	N74°04'50"E	33°07'30"
C3	129.47	250.00	66.22	128.03	N14°26'35"E	29°40'20"
C4	164.68	318.00	84.23	162.85	N14°26'35"E	29°40'20"
C5	252.29	50.00	35.60	58.00	N55°06'58"W	289°05'56"
C6	99.51	271.00	50.32	98.95	N40°59'56"E	21°02'20"
C7	89.96	121.00	35.99	88.98	N74°04'50"E	33°07'30"
C8	91.36	279.00	46.09	90.95	S45°51'37"W	18°45'41"
C9	277.80	321.00	148.27	269.21	S15°09'36"E	49°35'04"
C10	223.44	50.00	63.95	78.78	N42°20'47"W	256°02'33"
C11	498.88	497.00	272.73	478.19	S00°31'23"W	57°30'43"
C12	164.51	250.00	85.36	161.56	S79°57'28"E	37°42'09"
C13	232.95	170.00	138.93	215.15	N39°21'27"E	78°30'46"
C14	113.81	279.00	57.71	113.03	S86°55'39"W	23°22'23"
C15	220.39	220.00	120.44	211.29	N29°35'51"W	57°23'52"
C16	163.71	240.00	85.19	160.56	N79°16'02"W	39°05'01"
C17	9.33	220.00	4.66	9.33	N58°30'39"W	02°25'44"
C18	29.18	45.00	15.12	28.67	N71°49'03"W	37°09'04"
C19	41.79	45.00	22.54	40.30	N26°38'24"W	53°12'14"

LINE	LENGTH	BEARING
L1	248.63	N28°13'56"W
L2	146.26	S57°31'35"W
L3	19.48	N28°13'58"W
L4	71.54	S57°31'35"W
L5	80.41	N81°11'27"E
L6	25.96	N36°28'46"E
L7	208.65	N29°16'45"E
L8	139.46	S00°06'04"W
L9	164.19	S78°36'50"W
L10	53.20	N39°57'08"W
L11	166.71	S34°53'02"W
L12	140.08	S69°43'32"E
L13	88.51	N00°23'35"W
L14	23.65	N29°16'45"E

Exception to Plat

MINIMUM BUILDING ELEVATIONS		
Minimum Low Opening Elevation		
Location	NGVD Datum	City Datum
Lots 1-5, Blk 1	1316.0	128.6
Lots 6-19, Blk 1	1327.3	139.9
Lots 12-32, Blk 2	1326.4	139.0
Lots 1-9, Blk 6	1335.0	147.6
Lot 10, Blk 6	1335.0	147.6
Lots 21-26, Blk 6	1335.0	147.6

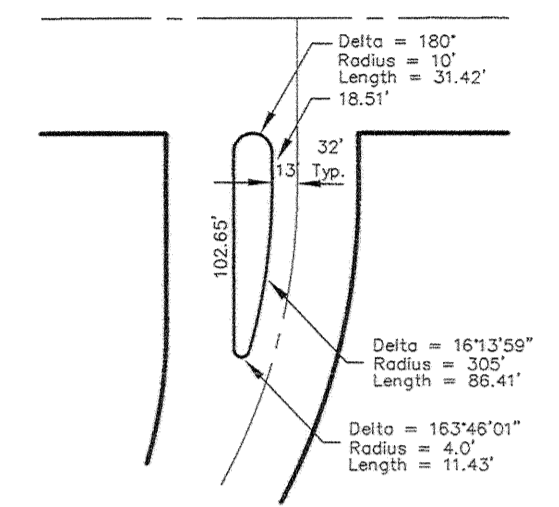
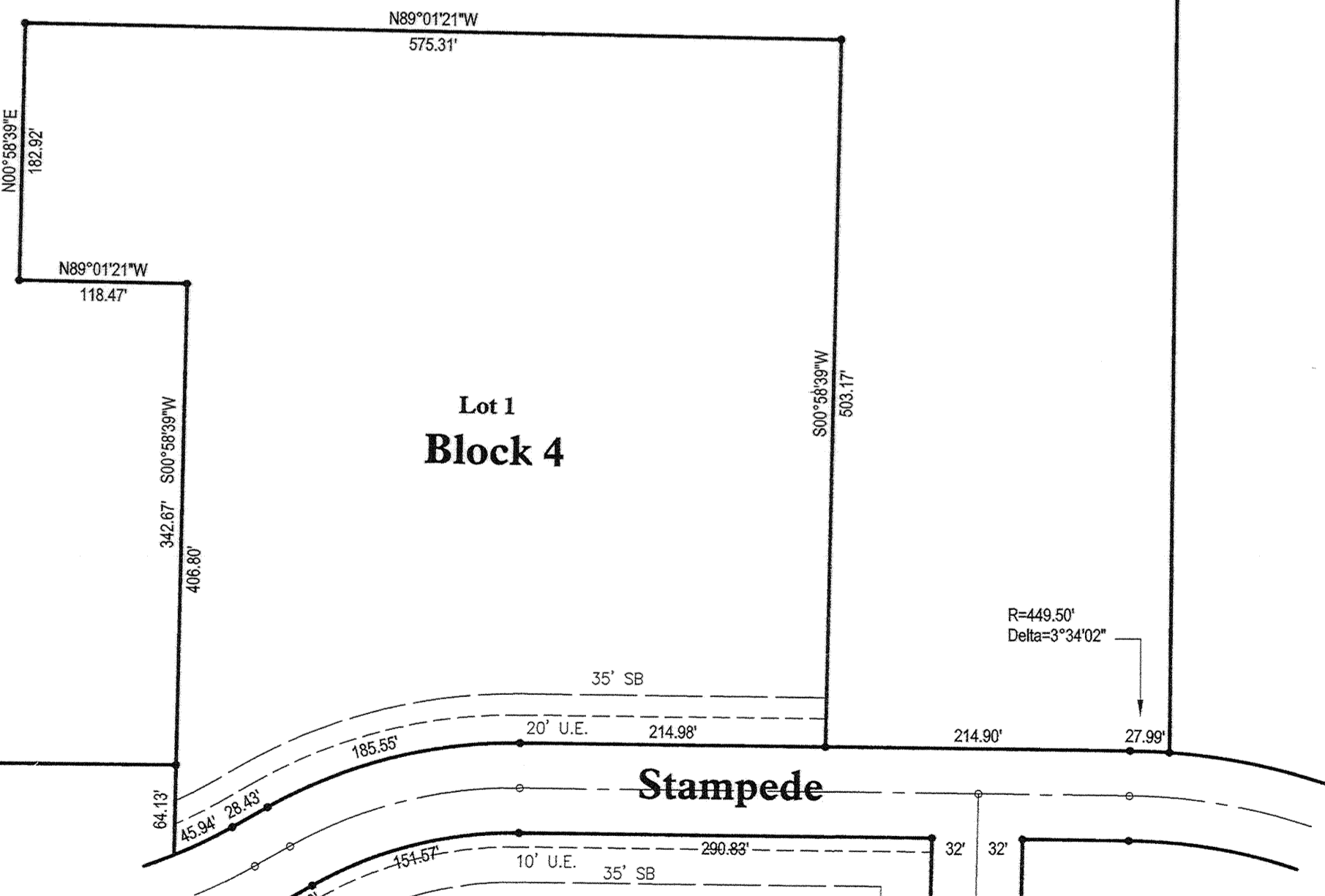

Reserve B Details

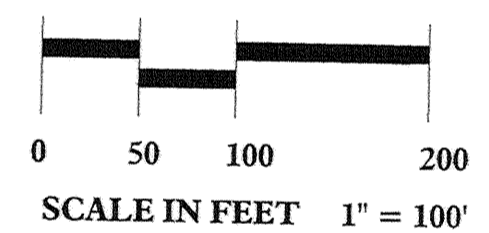
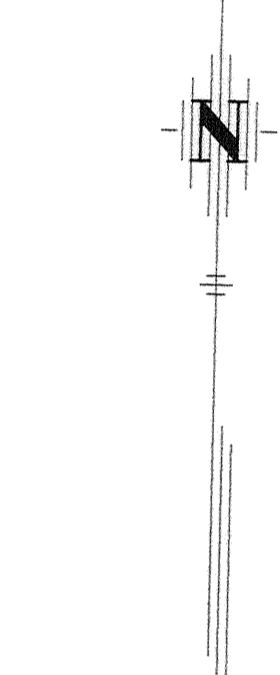

LEGEND

- Utility Easement 20' U.E.
- Drainage Easement 20' Dr. E.
- Iron Set
- Building Setback 30' SB
- Curve Label c2
- Line Label L2
- Center Line CL
- Monument Found

NOTE:

This Addition is subject to the conditions of the Planned Unit Development PUD 2000-0001.

BENCHMARKS:

- NGVD Datum
- 1. Railroad spike in power pole, approximately 25' south and 30' east of W 1/4 Corner, Section 35-27-2E. Elevation 1349.65
- 2. Square on south hub guard of RCBC just west of NW Corner of Section 35-27-2E. Elevation 1311.90

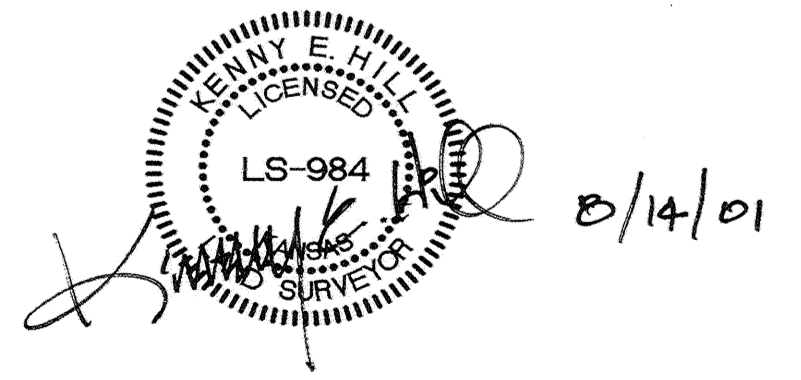

EQUESTRIAN ESTATES

An Addition to Wichita - Sedgwick County, Kansas
(Associated Zone Case PUD 2000-0001)