

CURVE TABLE						
CURVE	LENGTH	RADIUS	TANGENT	CHORD	BEARING	DELTA
C20	442.12	463.00	239.54	425.51	S00°52'37"E	54°42'42"
C21	130.56	417.50	65.81	130.02	N80°29'42"W	17°55'01"
C22	242.62	453.00	124.30	239.73	N16°20'27"E	30°41'14"
C23	92.35	253.00	46.70	91.84	N10°43'04"W	20°54'55"
C24	276.77	300.00	149.12	267.06	S05°15'16"W	52°51'36"
C25	252.26	50.00	35.62	58.02	N73°28'49"E	289°04'24"
C26	358.23	427.00	190.42	347.82	N69°05'04"W	48°04'06"
C27	205.70	220.00	111.69	199.18	N48°02'01"E	53°49'59"
C28	189.51	427.00	96.34	187.96	N02°23'03"W	25°25'46"
C29	185.42	600.00	93.46	184.69	N85°56'51"E	17°42'24"
C30	104.25	250.00	52.89	103.49	N83°39'31"W	23°53'30"
C31	252.29	50.00	35.60	58.00	S24°23'32"E	289°05'56"
C32	81.98	250.00	41.36	81.61	S75°00'06"W	18°47'16"
C33	111.97	603.00	56.15	111.81	S05°03'34"W	10°38'22"
C34	141.23	600.00	70.94	140.90	S78°27'21"E	13°29'11"
C35	62.10	205.00	31.29	61.86	S11°53'30"E	17°21'22"
C36	53.55	205.00	26.93	53.39	N13°05'14"W	14°57'55"
C37	252.29	50.00	35.60	58.00	S88°47'11"W	289°05'56"
C38	88.63	300.00	44.64	88.31	S85°33'29"W	15°55'40"
C39	70.45	45.00	44.77	63.47	N44°48'45"E	89°42'04"
C40	252.29	50.00	35.60	58.00	N04°01'19"E	289°05'56"
C41	62.74	427.00	31.42	62.68	N67°19'40"W	08°25'05"
C42	164.63	180.00	88.58	159.24	N42°40'53"W	52°30'24"
C43	133.37	250.00	68.31	131.79	S36°24'01"W	30°33'57"
C44	164.95	180.00	88.78	159.24	N25°25'48"E	52°30'24"
C45	252.29	50.00	35.60	58.00	S89°10'36"W	289°05'56"
C46	188.56	317.50	86.32	186.59	N75°20'15"E	30°25'05"
C47	202.73	382.50	103.61	200.36	N75°18'43"E	30°22'02"

Exception to Plat

Reserve F

Reserve G

Lot 1 Block 5

Lot 1 Block 4

Stampede

Horseback

Block 6

Reserve E

Block 6

Equestrian Cir.

1/16 Corner, NW1/4 Section 35-27-2E Found 1 1/4" Galv. Pipe

Reserve A

Block 15

Stampede

Triple Crown

Reserve C

Reserve C

SE Corner, NW1/4 Section 35-27-2E Found 1 1/4" Galv. Pipe

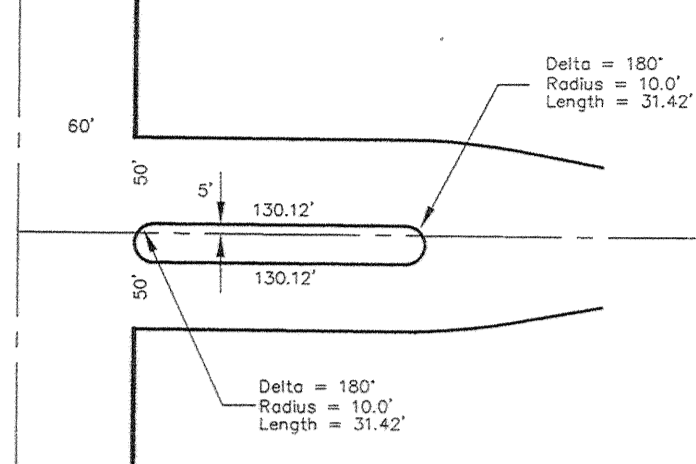

Reserve G Details

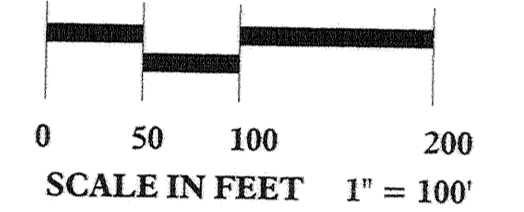

LEGEND

- Utility Easement 20' U.E.
- Drainage Easement 20' Dr. E.
- Iron Set
- Building Setback 30' SB
- Curve Label C2
- Line Label L2
- Center Line CL
- Monument Found

NOTE:

This Addition is subject to the conditions of the Planned Unit Development PUD 2000-0001.

BENCHMARKS:

- NGVD Datum
- 1. Railroad spike in power pole, approximately 25' south and 30' east of W 1/4 Corner, Section 35-27-2E. Elevation 1349.65
- 2. Square on south hub guard of RCBC just west of NW Corner of Section 35-27-2E. Elevation 1311.90

LINE	LENGTH	BEARING
L14	58.68	S21°10'32"E
L15	92.74	S00°15'37"E
L16	100.71	S31°41'04"W
L17	255.26	N00°59'51"E
L18	106.80	N89°27'13"W
L19	85.04	S74°56'59"W
L20	46.22	N05°36'16"W
L21	257.23	S10°22'45"W
L22	90.71	N65°36'28"E
L23	64.93	N00°15'37"W
L24	117.83	S71°42'46"E
L25	57.73	N20°34'12"W
L26	65.45	N03°12'45"W
L27	108.75	S85°58'41"E
L28	89.87	N77°05'40"E
L29	192.27	N26°28'44"E
L30	399.67	S71°32'12"E
L31	69.13	N51°41'00"E
L32	39.62	S21°07'03"W
L33	74.82	N68°52'57"W
L34	46.99	S21°07'03"W
L35	39.99	N16°28'45"W
L36	84.85	S30°49'24"E
L37	8.74	S10°22'45"W
L38	323.08	N89°27'13"W
L39	28.43	S60°07'42"W
L40	376.86	N89°30'16"W

MINIMUM BUILDING ELEVATIONS		
Minimum Low Opening Elevation		
Location	NGVD Datum	City Datum
Lots 1-5, Blk 1	1316.0	128.6
Lots 6-19, Blk 1	1327.3	139.9
Lots 12-32, Blk 2	1326.4	139.0
Lots 1-9, Blk 6	1335.0	147.6
Lot 10, Blk 6	1335.0	147.6
Lots 21-25, Blk 6	1335.0	147.6

CL-127th Street East

Complete Access Control

Basis of Bearings (Assumed Direction)

Conoco Pipe Line Company Easement
Film 1086, Page 0770
A 50 foot building setback from the pipeline is required.

SW Corner, NW1/4 Section 35-27-2E Found 3/4" Pipe

EQUESTRIAN ESTATES

An Addition to Wichita - Sedgwick County, Kansas

(Associated Zone Case PUD 2000-0001)

