

**EXPANSION JOINT**

NOTE: Extra Thickness to be Subsidiary to Price of Square Yards Pavement

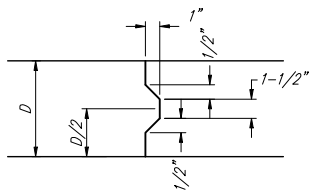

**KEYWAY DETAIL**

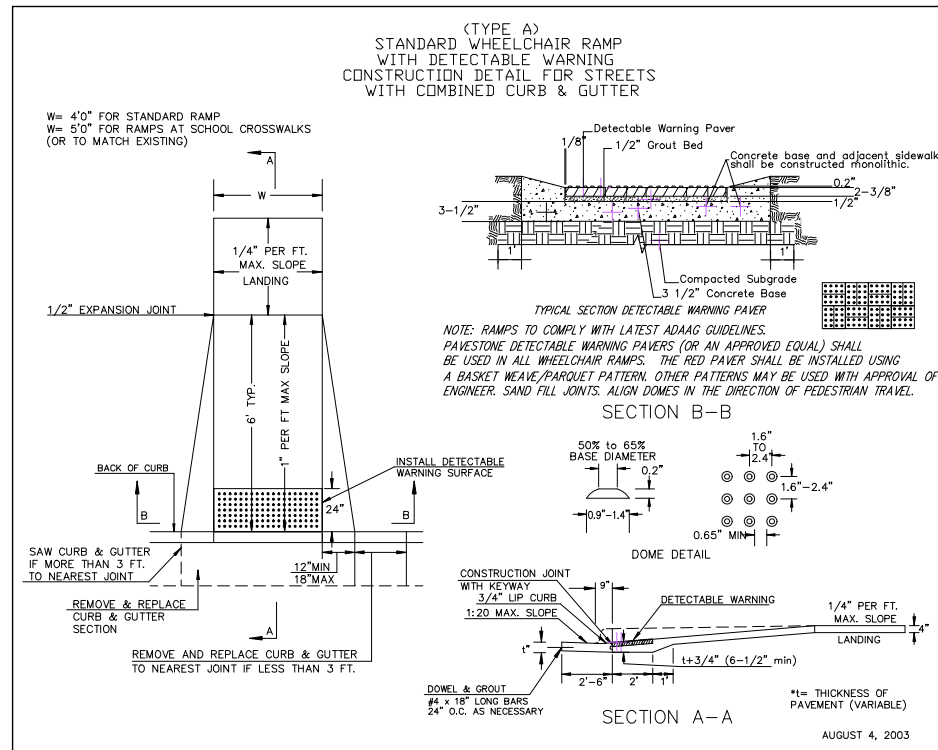

**WHEELCHAIR RAMP DETAIL**

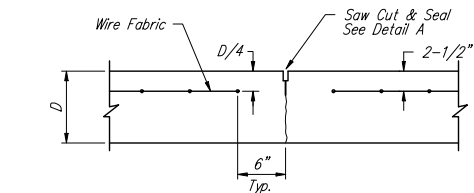
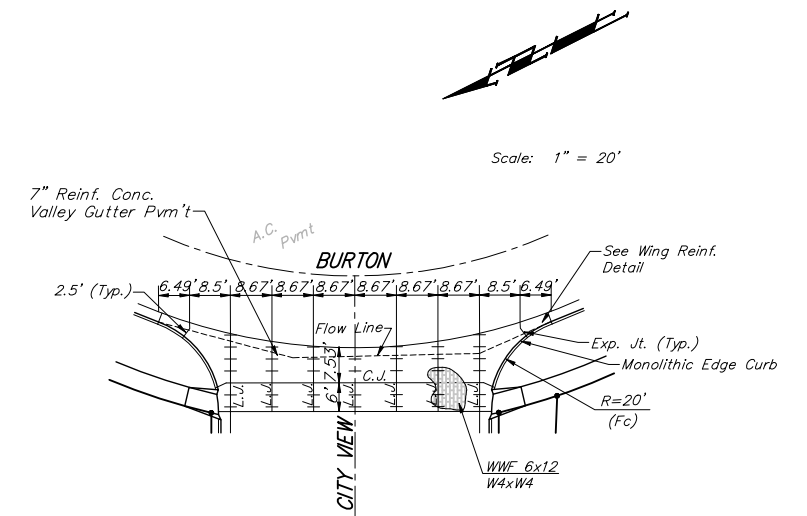

**CONTRACTION JOINT DETAIL (C.J.)**

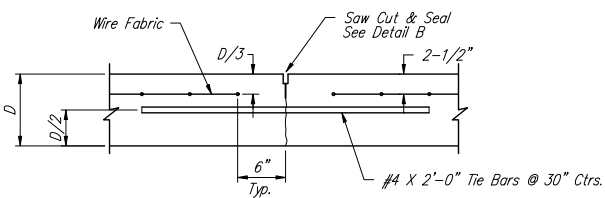

**LONGITUDINAL JOINT DETAIL (L.J.)**

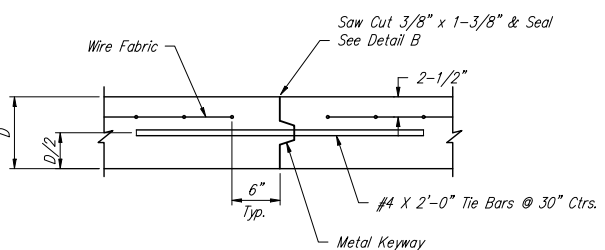

**OPTIONAL LONGITUDINAL JOINT DETAIL (L.J.) (CONSTRUCTION JOINT)**

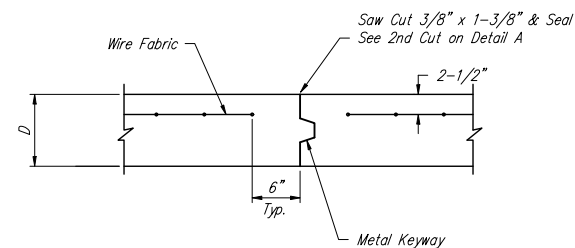

**OPTIONAL CONTRACTION JOINT (CONSTRUCTION JOINT)**

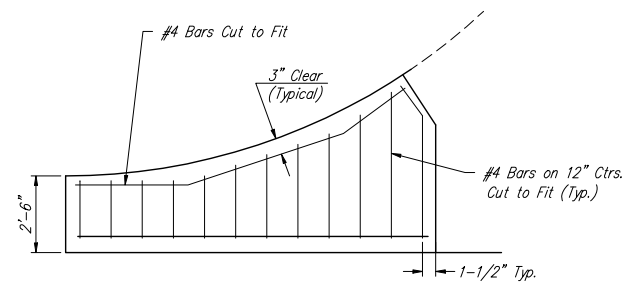

**WING REINFORCING DETAIL**

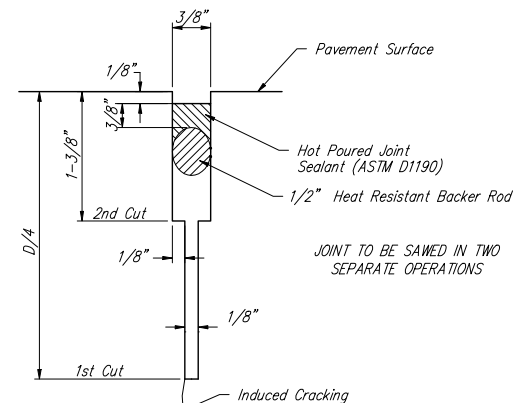

**SAW JOINT DETAIL "A"**

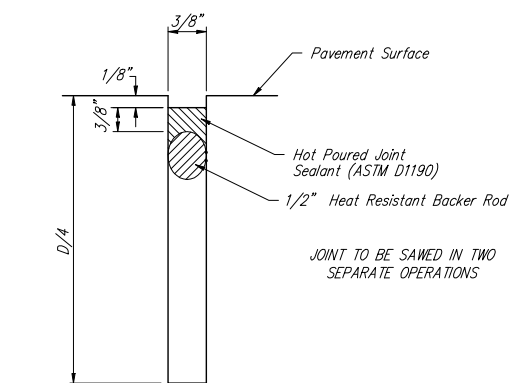

**SAW JOINT DETAIL "B"**

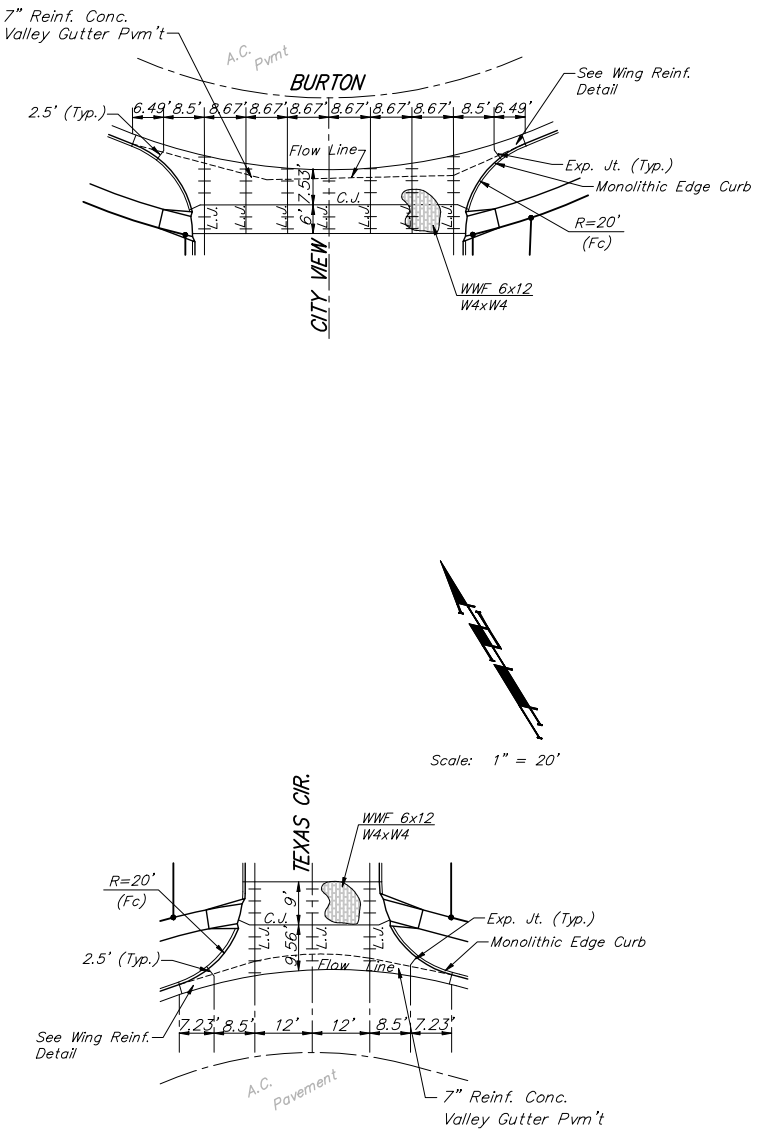

NOTE: 6" X 12" W4XW4 Wire Fabric Reinforcing Shall Be Placed So That The Wires With The 6" Spacing Will Run Parallel With The Longitudinal Joints.

<b>Baughman</b>		<b>VALLEY GUTTER DETAILS</b>	
Baughman Company, P.A. 315 Ellis St. Wichita, KS 67211 P 316262/7271 F 316262/0149			
ENGINEERING   SURVEYING   PLANNING   LANDSCAPE ARCHITECTURE			
PROJECT NUMBER 472-84060	DESIGN STAFF	DRAWN STAFF	
REVISIONS:	APPROVED	DATE	06/06
	SCALE	NONE	
	SHEET	<b>5 OF 37</b>	
E:\eng\Shadow Woods Addition\Phase 5\VGdetail.dwg			06-01-B467