

EXPANSION JOINT

NOTE: Extra Thickness to be Subsidiary to Price of Square Yards Pavement

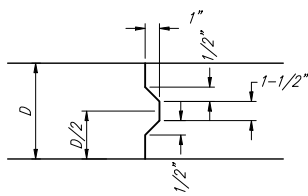

KEYWAY DETAIL

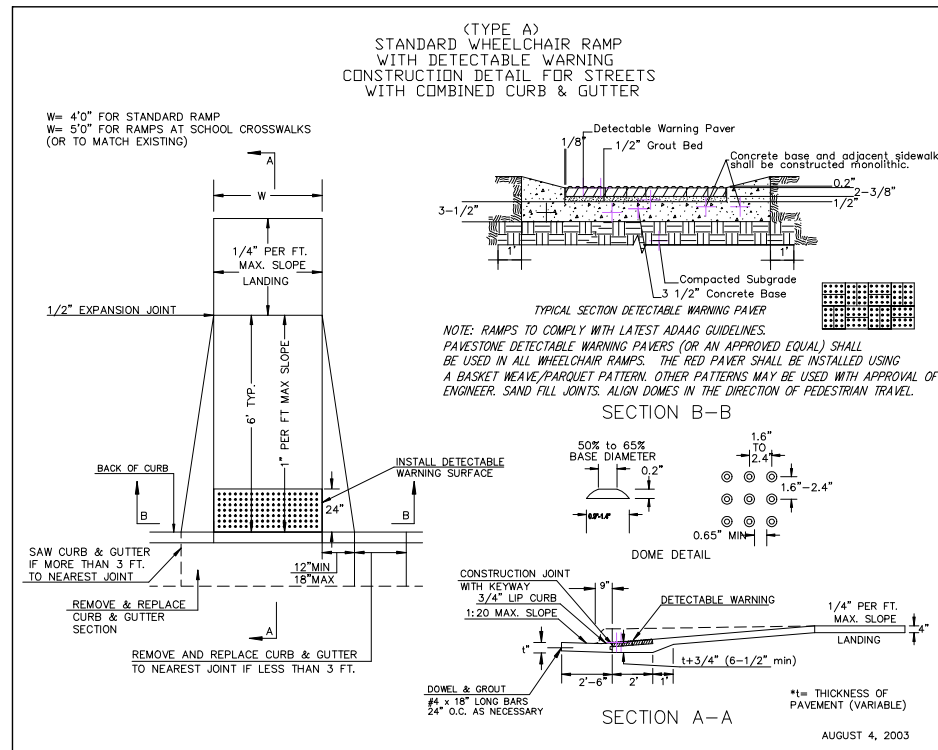

WHEELCHAIR RAMP DETAIL

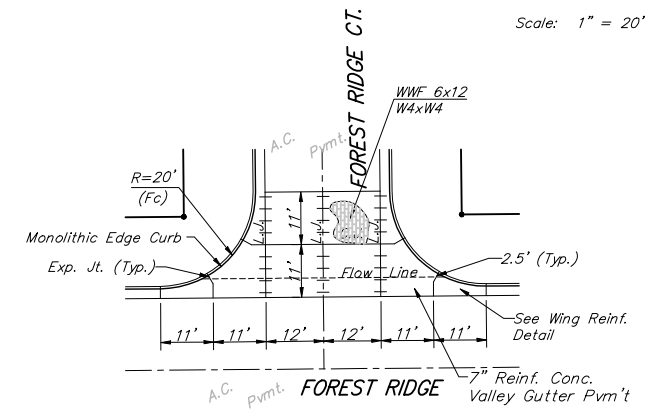

Scale: 1" = 20'

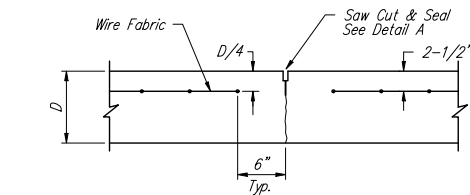

CONTRACTION JOINT DETAIL (C.J.)

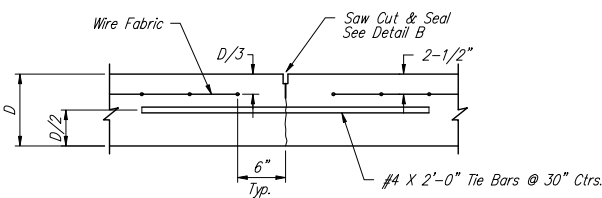

LONGITUDINAL JOINT DETAIL (L.J.)

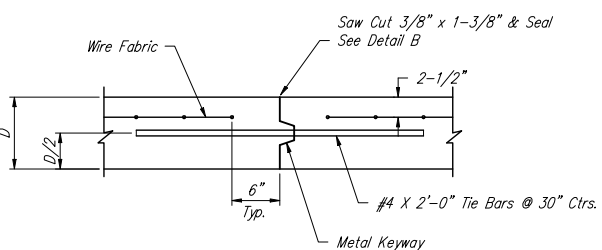

OPTIONAL LONGITUDINAL JOINT DETAIL (L.J.) (CONSTRUCTION JOINT)

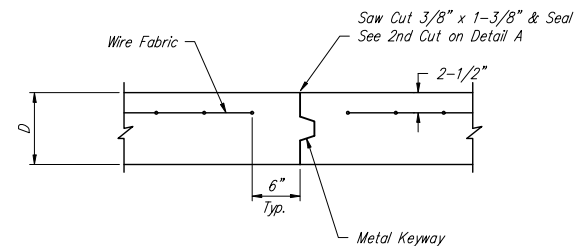

OPTIONAL CONTRACTION JOINT (CONSTRUCTION JOINT)

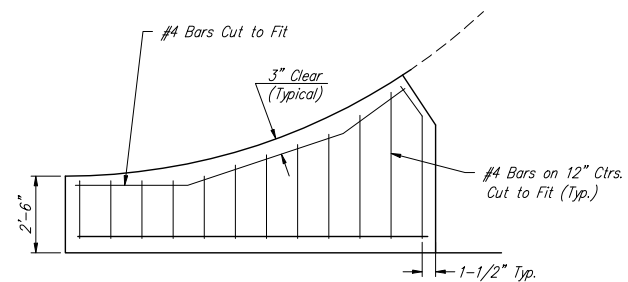

WING REINFORCING DETAIL

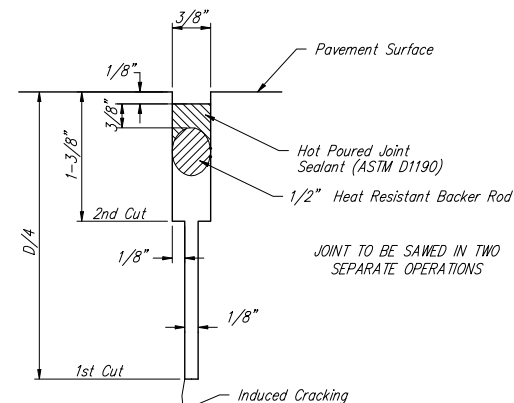

SAW JOINT DETAIL "A"

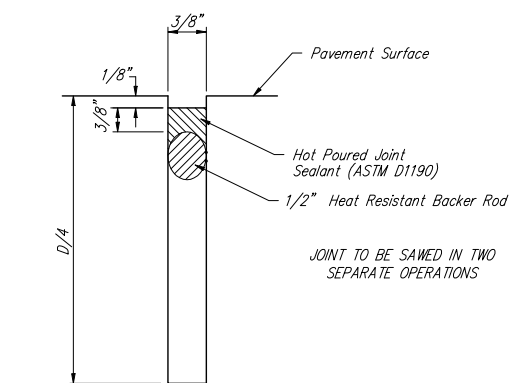

SAW JOINT DETAIL "B"

NOTE: 6" X 12" W4XW4 Wire Fabric Reinforcing Shall Be Placed So That The Wires With The 6" Spacing Will Run Parallel With The Longitudinal Joints.

Baughman		VALLEY GUTTER DETAILS	
Baughman Company, P.A. 315 Ellis St. Wichita, KS 67211 F 316-262-7771 F 316-262-0149			
ENGINEERING SURVEYING PLANNING LANDSCAPE ARCHITECTURE			
PROJECT NUMBER 472-84262	DESIGN STAFF	DRAWN STAFF	
REVISIONS:	APPROVED	DATE	08/05
	SCALE	NONE	
	SHEET	5 OF 52	
eylers landing 3rd/Vgdetail		05-07-E283	