

DEETER #2433 GRATE

24" x 24" Frame and Grate Detail

NOTE: Grates shall be imprinted on the top surface with "CITY OF WICHITA" using letters at least 1" in height. Other marking methods may be approved by the engineer.

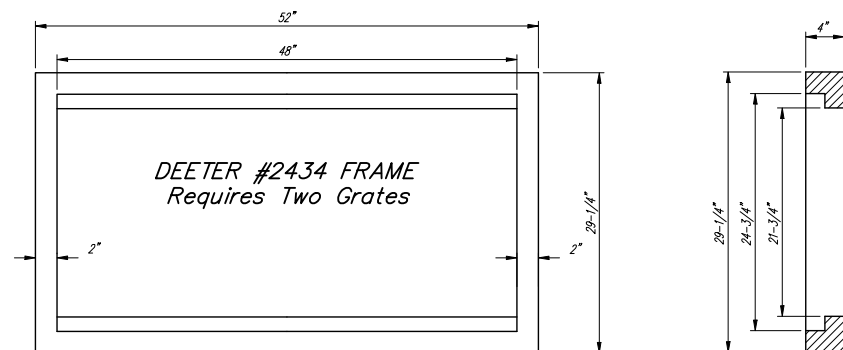

Double 24" x 24" Frame Detail

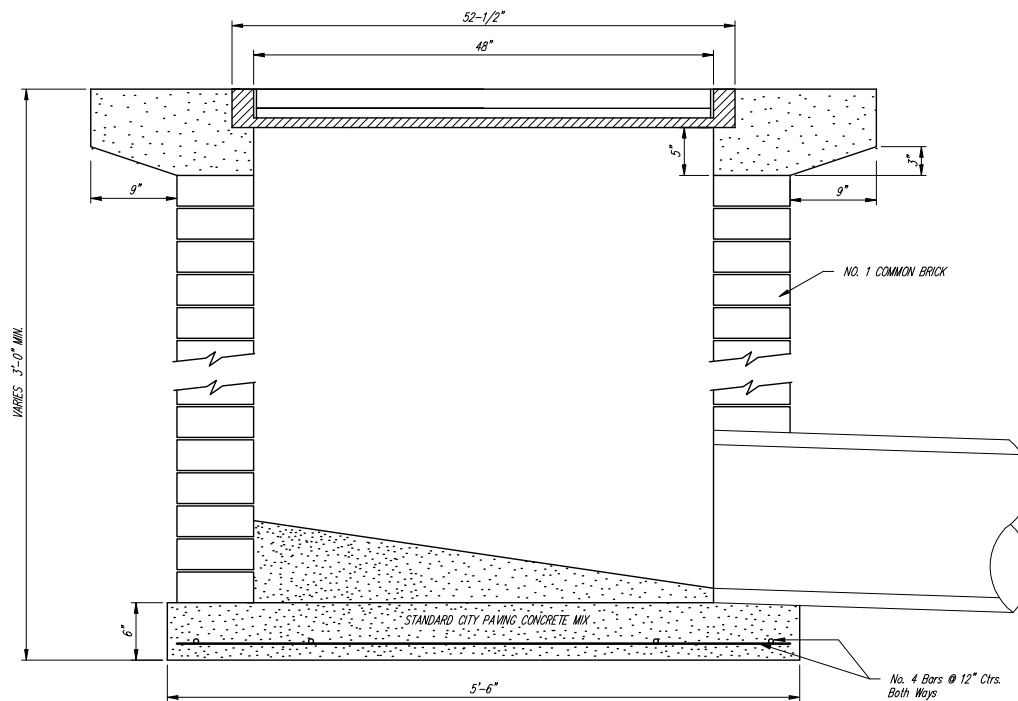
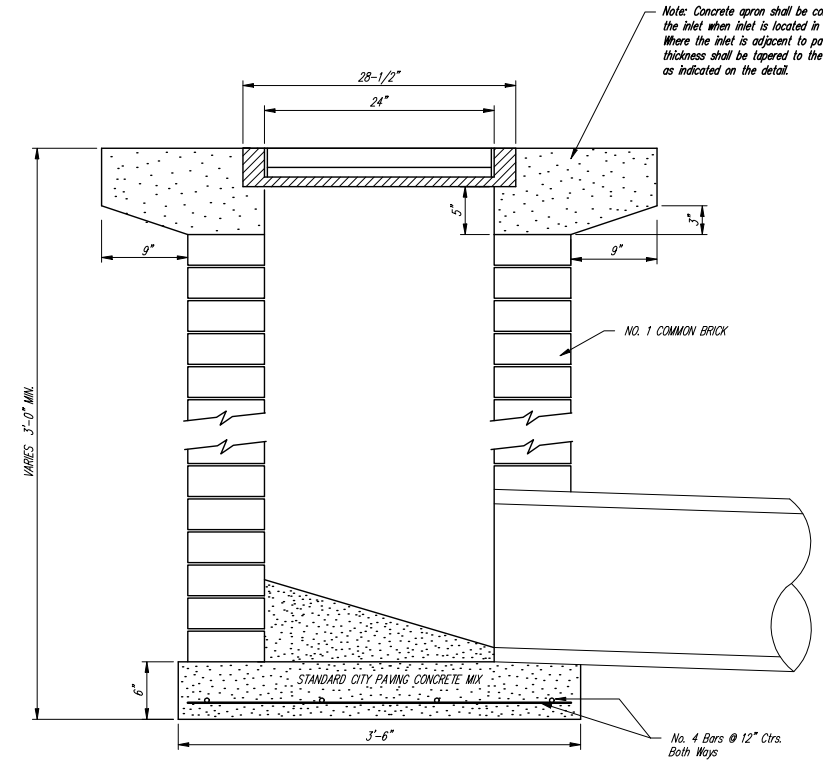
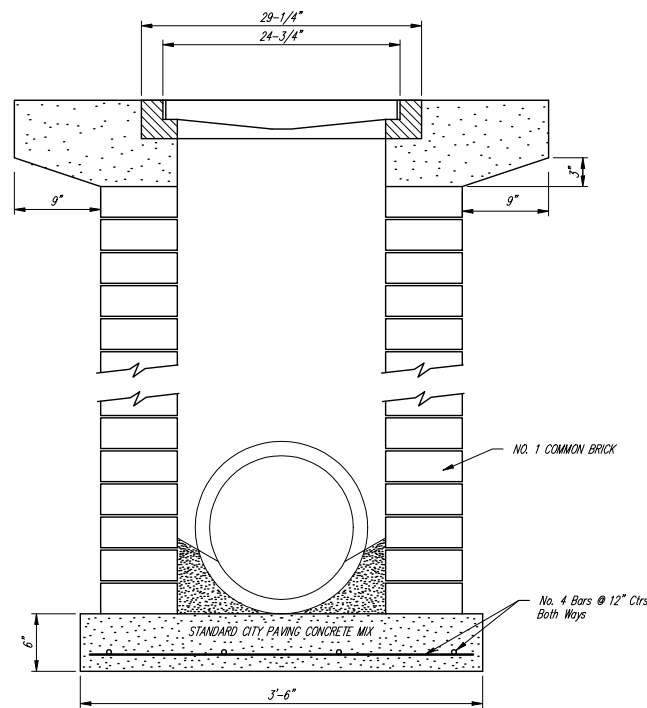

| | | |
|---|--------------------------|-----------------|
| | City of Wichita Standard | |
| | Drop Inlet Detail | |
| <small>Baughman Company, P.A. 315 8th St. Wichita, KS 67211 F 316-262-7271 F 316-262-0149 ENGINEERING SURVEYING PLANNING LANDSCAPE ARCHITECTURE</small> | | |
| PROJECT NUMBER 472-84262 | DESIGN C.O.W. | DRAWN STAFF |
| REVISIONS: | APPROVED | DATE 08/05 |
| | SCALE NONE | |
| | SHEET | 34 OF 52 |