

**EXPANSION JOINT**

NOTE: Extra Thickness to be Subsidiary to Price of Square Yards Pavement

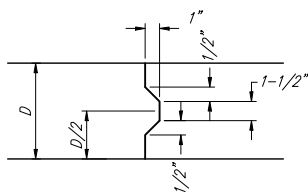

**KEYWAY DETAIL**

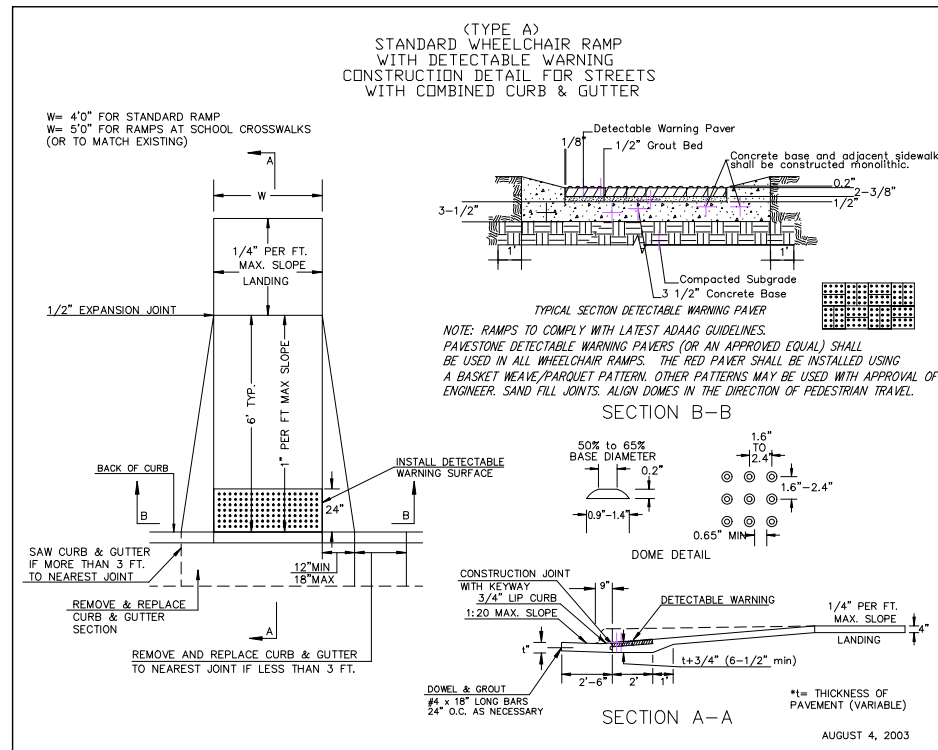

**WHEELCHAIR RAMP DETAIL**

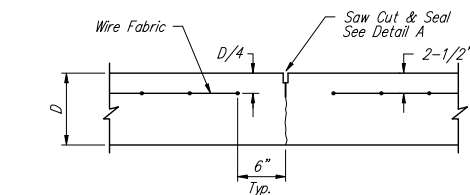

**CONTRACTION JOINT DETAIL (C.J.)**

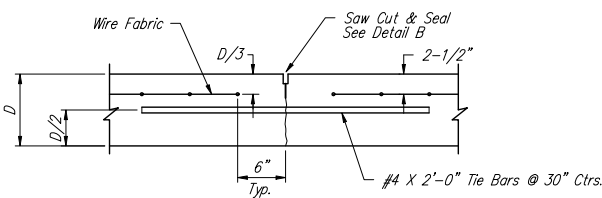

**LONGITUDINAL JOINT DETAIL (L.J.)**

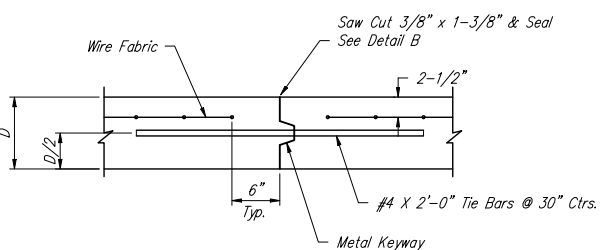

**OPTIONAL LONGITUDINAL JOINT DETAIL (L.J.) (CONSTRUCTION JOINT)**

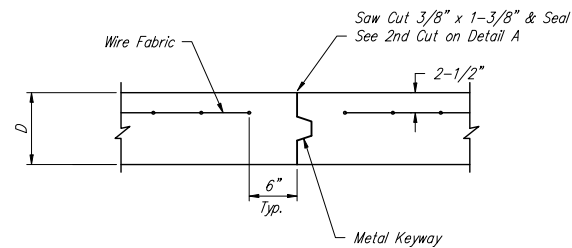

**OPTIONAL CONTRACTION JOINT (CONSTRUCTION JOINT)**

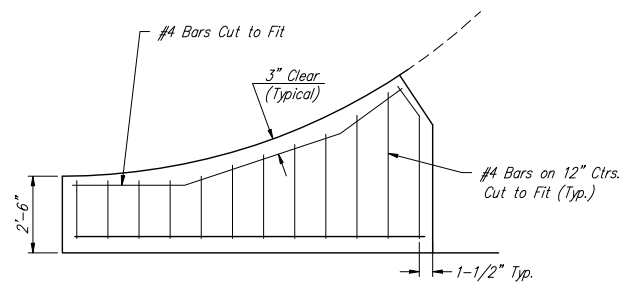

**WING REINFORCING DETAIL**

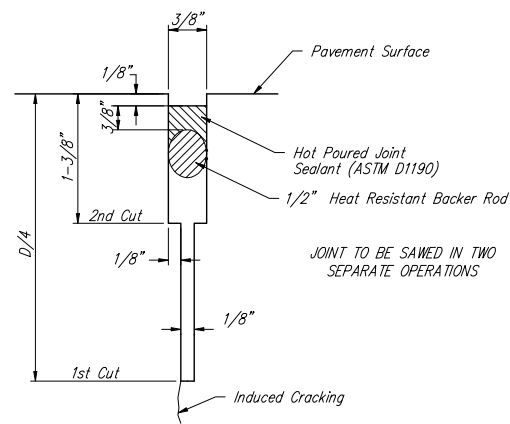

**SAW JOINT DETAIL "A"**

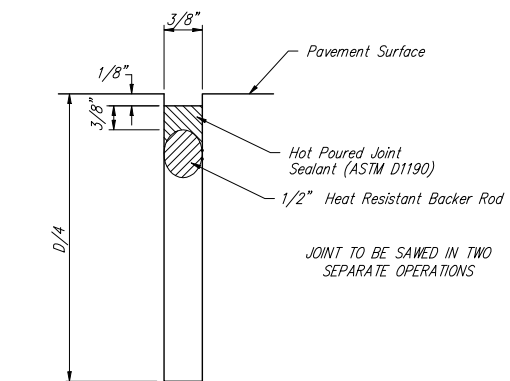

**SAW JOINT DETAIL "B"**

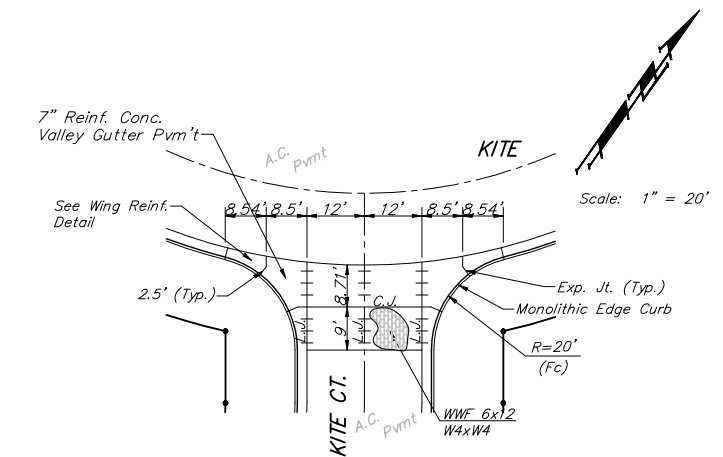
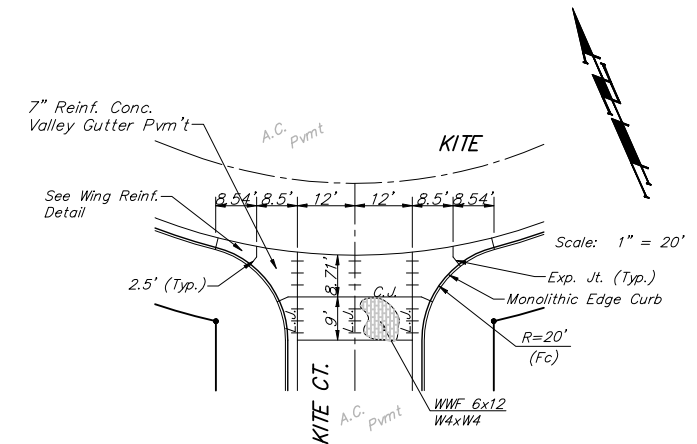

NOTE: 6" X 12" W4XW4 Wire Fabric Reinforcing Shall Be Placed So That The Wires With The 6" Spacing Will Run Parallel With The Longitudinal Joints.

<b>Baughman</b>		<b>VALLEY GUTTER DETAILS</b>	
Baughman Company, P.A. 315 Ellis St. Wichita, KS 67211 P 316-262-7271 F 316-262-0149			
ENGINEERING   SURVEYING   PLANNING   LANDSCAPE ARCHITECTURE			
PROJECT NUMBER 472-84264	DESIGN STAFF	DRAWN STAFF	
REVISIONS:	APPROVED	DATE 01/06	
	SCALE NONE	SHEET <b>5 OF 44</b>	
Falcon\Falls2nd\Phil\Vgdetail		05-10-E376	