

VERTICAL RISER DETAILS ADOPTED AS STANDARD DESIGN BY CITY OF WICHITA, KANSAS JANUARY 2001

SEWER SERVICE TABLE						
NO.	TYPE	LOCATION			FOR INFORMATION ONLY	
		LOT NO.	BLOCK	LINE NO. STATION/DIRECTION	APPROXIMATE LENGTH 4" PIPE	
					VERTICAL	HORIZONTAL
1	TEE SERVICE CONNECTION	19	2	1 21+30.8/LT.	9'	15'
2	TEE SERVICE CONNECTION	18	2	1 22+15.8/LT.	11'	15'
3	TEE SERVICE CONNECTION	17	2	1 23+00.8/LT.	13'	15'
4	TEE SERVICE CONNECTION	16	2	1 23+85.8/LT.	11'	15'
5	TEE SERVICE CONNECTION	15	2	1 24+70.8/LT.	10'	15'
6	TEE SERVICE CONNECTION	14	2	1 25+55.8/LT.	9'	15'
7	TEE SERVICE CONNECTION	13	2	1 26+40.8/LT.	8'	15'
8	TEE SERVICE CONNECTION	12	2	1 27+25.8/LT.	7'	15'
9	TEE SERVICE CONNECTION	1	5	1 41+12.7/RT.	8'	15'
10	TEE SERVICE CONNECTION	3	5	1 42+90.4/RT.	7'	13'
11	TEE SERVICE CONNECTION	53	2	2 11+ 70.8 /LT. 71	3'	13'
12	TEE SERVICE CONNECTION	57	2	2 15+ 140.8 /LT. 64	6'	14.5'
* 13	TEE SERVICE CONNECTION	24	1	2 34+ 80.8 /RT. 75.6	6'	22'
* 14	TEE SERVICE CONNECTION	23	1	2 35+74.8/RT.	6'	22'
* 15	TEE SERVICE CONNECTION	22	1	2 36+59.8/RT.	6'	22'
* 16	TEE SERVICE CONNECTION	20	1	2 38+29.8/RT.	6'	22'
* 17	TEE SERVICE CONNECTION	19	1	2 39+14.8/RT.	7'	22'
* 18	TEE SERVICE CONNECTION	18	1	2 39+99.8/RT.	7'	22'
* 19	TEE SERVICE CONNECTION	17	1	2 40+87.5/RT.	6'	22'
* 20	TEE SERVICE CONNECTION	15	1	2 42+61.3/RT.	6'	22'
* 21	TEE SERVICE CONNECTION	14	1	2 43+46.3/RT.	7'	22'
* 22	TEE SERVICE CONNECTION	47	2	3 14+05.3/LT.	9'	13'
* 23	TEE SERVICE CONNECTION	20	2	3 14+ 100.8 /RT. 19.3	8'	13'
24	TEE SERVICE CONNECTION	46	2	3 14+85.6/LT.	10'	13'
25	TEE SERVICE CONNECTION	21	2	3 15+04.9/RT.	11'	13'
26	TEE SERVICE CONNECTION	22	2	3 15+90.1/RT.	10'	13'
27	TEE SERVICE CONNECTION	45	2	3 15+90.5/LT.	10'	13'
28	TEE SERVICE CONNECTION	23	2	3 16+75.1/RT.	9'	13'
29	TEE SERVICE CONNECTION	44	2	3 16+95.5/LT.	9'	13'

* REVISED 5-24-07

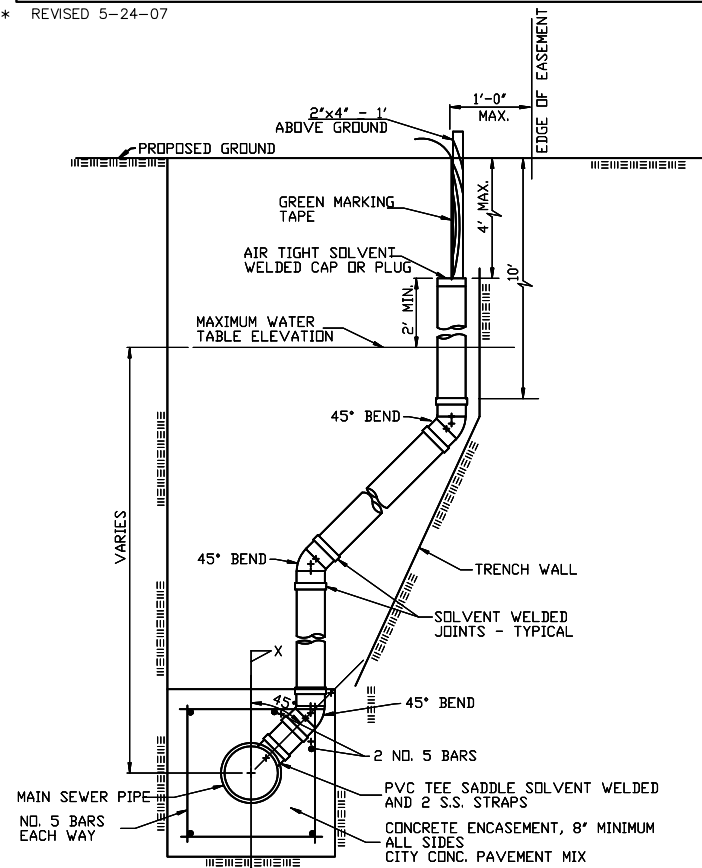

METHOD "A"

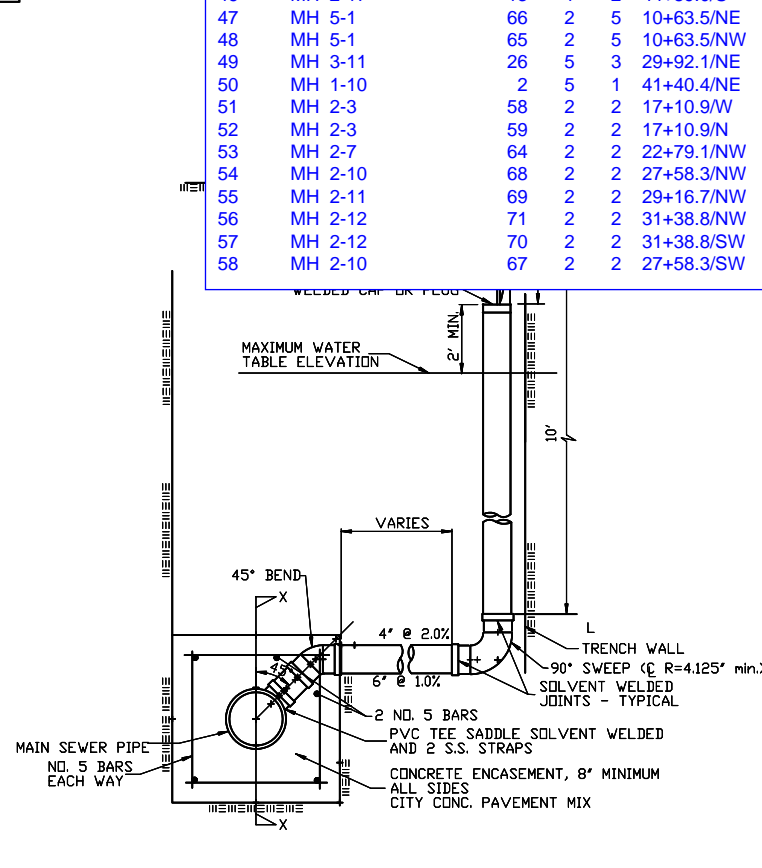

METHOD "B"

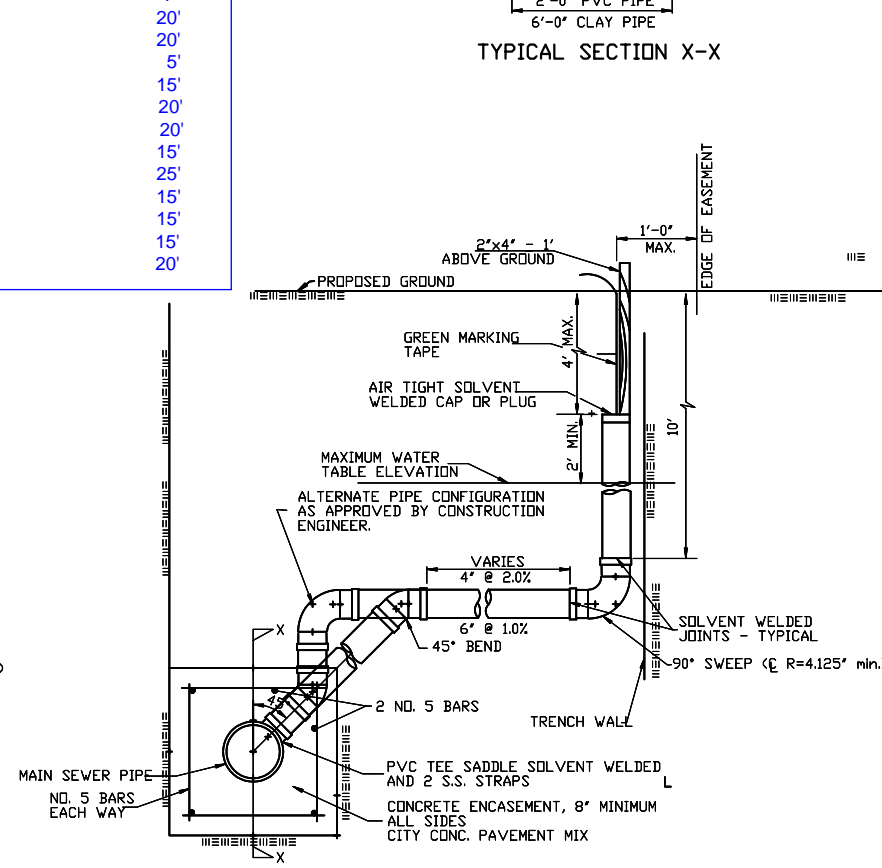

METHOD "C"

NOTE: RISER PIPE REQUIREMENTS AT MANHOLE STUBS SHALL BE SIMILAR TO THOSE SHOWN ABOVE.

SEWER SERVICE TABLE						
NO.	TYPE	LOCATION			FOR INFORMATION ONLY	
		LOT NO.	BLOCK	LINE NO. STATION/DIRECTION	APPROXIMATE LENGTH 4" PIPE	
					VERTICAL	HORIZONTAL
30	TEE SERVICE CONNECTION	43	2	3 18+00.5/LT.	8'	13'
31	TEE SERVICE CONNECTION	42	2	3 19+22.0/LT.	6'	13'
32	TEE SERVICE CONNECTION	24	5	3 28+24.1/RT.	6'	13'
33	TEE SERVICE CONNECTION	4	4	4 11+77.4/LT.	6'	13'
34	TEE SERVICE CONNECTION	3	4	4 13+36.8/LT.	7'	13'
35	TEE SERVICE CONNECTION	2	4	4 14+44.3/LT.	8'	13'
36	TEE SERVICE CONNECTION	11	5	8 14+12.8/LT.	8'	13'
37	TEE SERVICE CONNECTION	10	5	8 14+97.8/LT.	8'	13'
38	TEE SERVICE CONNECTION	9	5	8 15+90.8/LT.	9'	13'
39	TEE SERVICE CONNECTION	8	5	8 16+67.8/LT.	9'	13'
40	TEE SERVICE CONNECTION	6	5	8 17+29.3/RT.	10'	7'
41	TEE SERVICE CONNECTION	7	5	8 17+51.2/LT.	10'	13'
42	TEE SERVICE CONNECTION	10	2	8 20+26.3/LT.	7'	13'
43	TEE SERVICE CONNECTION	11	2	8 21+11.3/LT.	7'	13'
44	TEE SERVICE CONNECTION	12	2	8 21+96.3/LT.	6'	13'
45	MH 2-14	25	1	2 34+15.8/S		22'
46	MH 2-17	13	1	2 44+89.0/S		7'
47	MH 5-1	66	2	5 10+63.5/NE		20'
48	MH 5-1	65	2	5 10+63.5/NW		20'
49	MH 3-11	26	5	3 29+92.1/NE		5'
50	MH 1-10	2	5	1 41+40.4/NE		15'
51	MH 2-3	58	2	2 17+10.9/W		20'
52	MH 2-3	59	2	2 17+10.9/N		20'
53	MH 2-7	64	2	2 22+79.1/NW		15'
54	MH 2-10	68	2	2 27+58.3/NW		25'
55	MH 2-11	69	2	2 29+16.7/NW		15'
56	MH 2-12	71	2	2 31+38.8/NW		15'
57	MH 2-12	70	2	2 31+38.8/SW		15'
58	MH 2-10	67	2	2 27+58.3/SW		20'

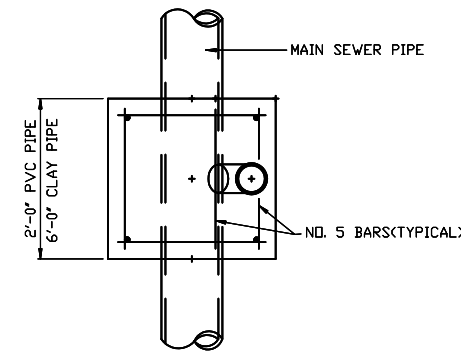

TYPICAL PLAN VIEW

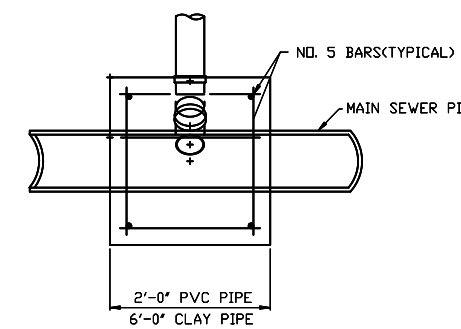

TYPICAL SECTION X-X

GENERAL NOTES

- RISERS.** Risers shall be installed to serve all lots or tracts where the sanitary sewer main is below the water table. Risers shall also be installed to serve all lots and tracts where the sanitary sewer main depth is greater than 12 feet below the proposed ground elevation. Installation of risers because of field conditions shall be as approved by the Construction Engineer. The location of the risers to serve developed property shall be approved by the property owner and the Construction Engineer.
- PIPE STUBS.** Pipe stubs shall be installed in manholes where connection as determined by the Construction Engineer. The vertical distance between the flowline of the manhole pipe stub and the flowline of the sanitary sewer main out of the manhole shall not exceed 2 feet. Risers shall be utilized at manhole pipe stubs as indicated in Note 1. Manhole pipe stubs shall be set such that the top of the stub is not lower than the top of the sanitary sewer main.
- SIZING.** Pipe stubs and risers shall be sized according to the plans and riser table where risers are indicated by the plans. Where risers or pipe stubs are required because of field conditions, the risers and stubs shall be six-inch diameter for commercial or industrial properties and 4" or 6" diameter for residential properties, based on lot size and sanitary sewer main depth. Sizing of risers and stubs shall be approved by the Construction Engineer prior to installation.
- RISER OR STUB MATERIAL.** Risers and stubs shall be constructed of Schedule 40 PVC Pipe, meeting the requirements of the latest revision of A.S.T.M. All pipe joints shall be solvent welded.
- REINFORCED CONCRETE ENCASEMENT.** Riser connections to clay pipe sanitary sewers shall be reinforced concrete encased both ways from the riser centerline. The reinforced concrete encasement shall extend three feet from the riser centerline or stop at the first sanitary sewer pipe joint within three feet of the riser centerline. Riser connections to PVC Sanitary Sewer mains shall be reinforced concrete encased one foot each way from the riser centerline. The concrete encasement shall be reinforced using reinforcing steel as shown in the appropriate detail. The concrete shall conform to the City Standard Specifications for concrete pavement.
- BEDDING.** Bedding around the sanitary sewer riser shall be compacted Pipe Bedding, Type 1 or 2. The bedding shall be placed and compacted from the depth of the sanitary sewer main to the top of the sanitary sewer riser pipe. Compacted Pipe Bedding Type 1 or 2 shall be required for all risers whether constructed in vertical wall or sloped wall trenches. Bedding material and construction practices shall be approved by the Construction Engineer prior to installation.
- SUPPORT OF RISERS.** Sanitary sewer riser pipe shall be supported during trench backfill. The riser pipe shall be held in a vertical position at all times until trench backfill and compaction has been completed. Contractor's methods for supporting and backfilling the riser pipe shall be approved by the Construction Engineer.
- PLUGGING.** The ends of the riser pipes and manhole stubs shall be plugged using an airtight solvent welded cap or plug. Cap or plug fittings shall be approved by the Construction Engineer prior to installation. Caps or plugs which do not provide an airtight seal will not be accepted.
- TOP OF THE RISER PIPE.** The top elevation of the sanitary sewer riser pipe shall be built per plan elevations, unless otherwise directed by the Construction Engineer. Where riser elevations are not shown on the plans, the top of the risers shall be set at an elevation four feet below the proposed ground surface. If ground water is encountered, the top of the riser pipe shall be set at an elevation two feet (min.) above the maximum water table elevation, regardless of the riser elevation shown on the plans.
- MARKING.** Locations of ends of the sanitary sewer riser pipe shall be marked by fastening green colored plastic tape to the end of the riser. The tape shall be supported by a length of wooden 2" x 4", extending from the top of the riser pipe to the proposed ground surface. The green tape shall be visible and extend one foot above the proposed ground surface. The green tape shall be 4 mil Polyethylene film with a minimum width of three inches, specifically manufactured for the purpose of identification of underground sewers.
- LOCATION MEASURES.** The project inspector shall record and document the location of all risers constructed as measured from the nearest manhole, indicating the direction from the manhole, the direction and distance from the main, riser size, and elevation of the top of the riser.
- RISER LOCATION.** The riser shall be located per plan if shown. If not shown on the plan, the riser shall be located at the center of the lot, within one foot of the property side of the easement for the lot being served. All riser locations shall be approved by the Construction Engineer prior to installation.
- PAYMENT.** "Sanitary sewer risers" shall be paid for at the contract unit price per each, which price shall be full compensation for all pipe, fittings, marking tape, length of wooden 2 x 4, reinforced concrete encasement, support during backfill, backfill, labor, site restoration, and any other items necessary to complete the work.
"Manhole stubs" shall be paid for at the contract unit price per each, which shall be full compensation for all labor, material, and incidentals necessary to complete the work including all pipe, fittings, reinforced concrete encasement, and all other items as required and listed for "Sanitary Sewer Risers".

THE CITY OF WICHITA

CITY ENGINEER'S OFFICE
CITY HALL - SEVENTH FLOOR
455 NORTH MAIN STREET
WICHITA, KANSAS 67202
(316) 268-4501
(316) 268-4114 FAX

**VERTICAL
RISER
DETAIL**

JAMES L. ARMOUR, P.E. - CITY ENGINEER

PROJECT NUMBER 468-84321	INDEX CODE 744218
DATE Jan 07	Sheet 4 of 31