

OPTIONAL DOLLAR GENERAL PLAN

NOTE: CONTRACTOR HAS RIGHT-OF-ENTRY TO PERFORM WORK ON THIS PROPERTY.

THE PROPOSED ASPHALT PAVEMENT SHOWN ON THIS SHEET SHALL BE PAID FOR AS "5" ASPHALT PAVEMENT (3" BIT. BASE)(DOLLAR GENERAL)". THIS MATERIAL SHALL CONFORM TO CITY MIX SC-1 FOR THE 2" SURFACE AND BC-1 FOR THE 3" BASE.

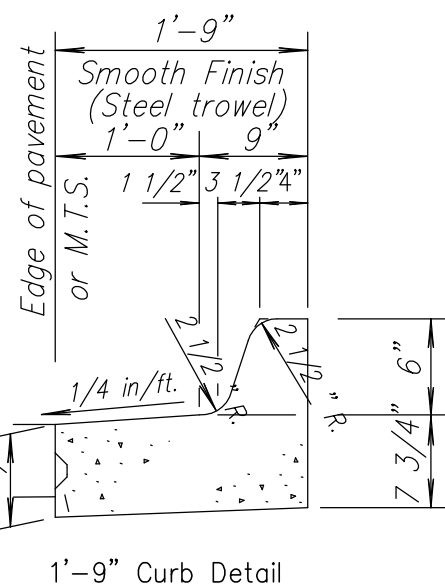

SUMMARY OF QUANTITIES

BID ITEM (LUMP SUM)	QUANTITY	UNIT	REMARKS
DOLLAR GENERAL ITEMS			
Excavation (Dollar General)	60	C.Y.	
Wheelchair Ramp (Dollar General)	1	Each	
Removal of Existing Structures (Dollar General)	1	L.S.	
BID ITEM (MEASURED QUANTITY)			
DOLLAR GENERAL ITEMS:			
Parking Lot Removal (Dollar General)	5,766.66	S.F.	
5" Asphalt Pavement, (3" Bit. Base)(Dollar General)	5,445	S.F.	
Curb (1'-9") (Dollar General)	153.59	L.F.	

J:\Civil\05709\dwg\details\05709-dillons.dwg 01/29/2007 10:56:28 AM CST



CENTRAL AND OLIVER INTERSECTION
PROJECT NAME

SPECIAL GRADING AND PAVING PLAN
SHEET TITLE

JRA DESIGN BY. JSB DRAWN BY. JRA CHECKED BY.

JAN. 2007 DATE 05709 JOB NO. 12 / 68 SHEET/OF