

BENCHMARK:
 BM # 1 - City of Wichita Disc in the Northwest Corner of 37th Street North and Womer Elev. = 1324.06 MSL
 BM # 2 - "C" Cut on the Top of Curb in the NE Corner of the Parking Lot for The Word of Life Church at 37th Street North & Meridian. Elev. = 1323.11 MSL
 BM # 3 - RR Spike in the East Face of Light Pole at the Southwest Corner of 34th Street North & Meridian. Elev. = 1320.32 MSL

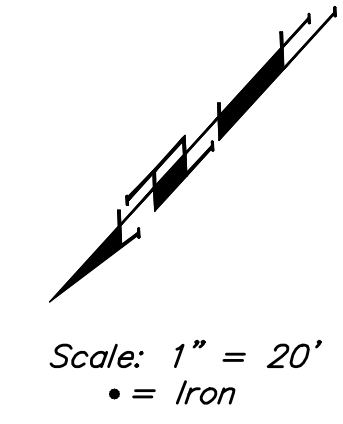

MESA VERDE ADDITION

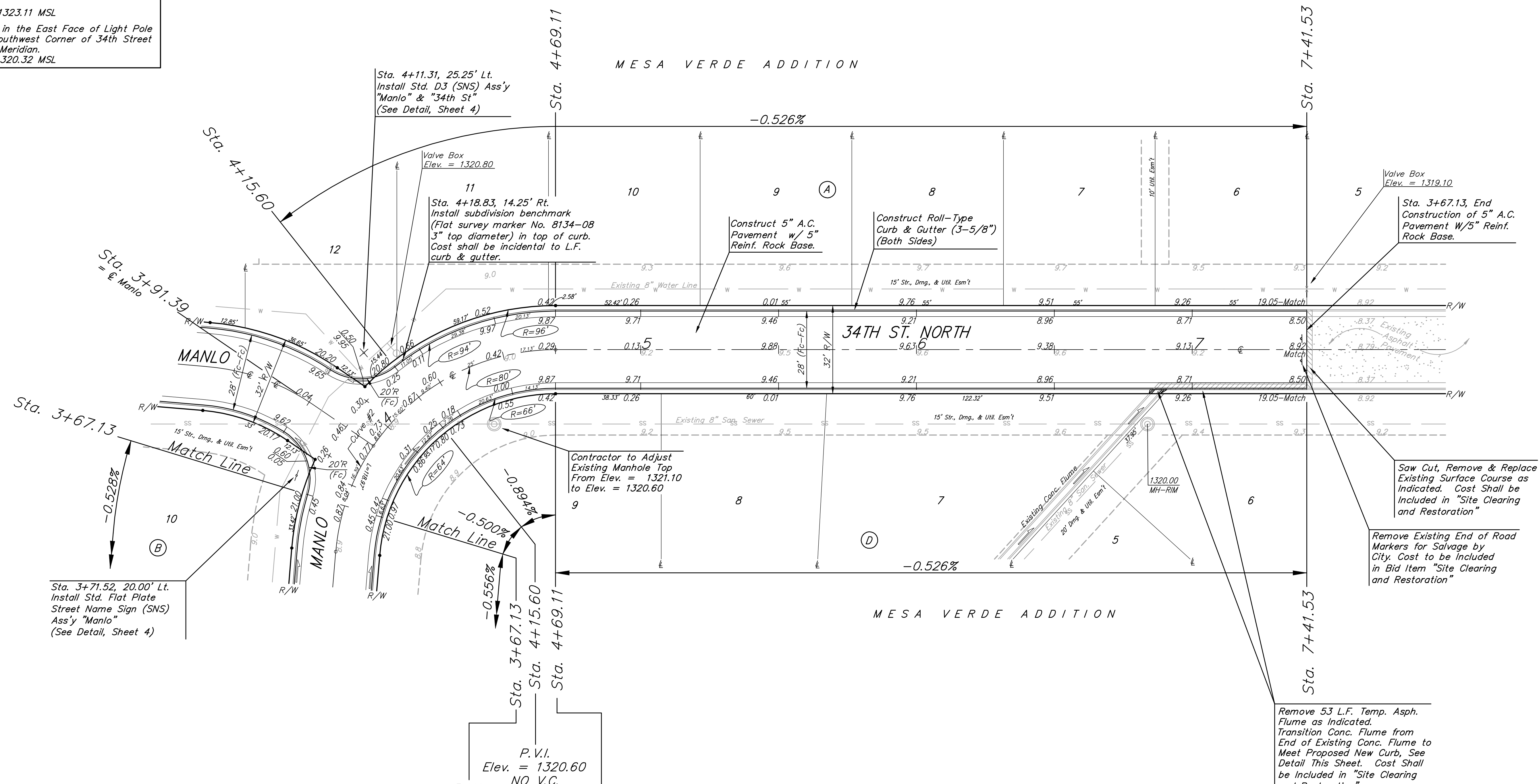

Curve #2
 Curve Data Based on Centerline
 Rad. = 80' Delta = 85° 12' 08" Tangent = 73.57'
 Arc = 118.97' L.C. = 108.30' Def/Ft. = 21.48497 Min.

Station	Arc	FACE CHORD LENGTHS		Defl.	T. Defl.
		B Lt.	B Rt.		
3+50.14	-	-	-	0'00"00"	0'00"00"
3+67.13	16.99'	21.62'	12.29'	6'05"02"	6'05"02"
3+75.00	7.87'	10.03'	5.70'	2'49"05"	8'54"07"
4+00.00	25.00'	31.74'	18.05'	8'57"07"	17'51"14"
4+13.60	15.60'	19.86'	11.29'	5'35"10"	23'26"24"
4+25.00	9.40'	11.98'	6.81'	3'21"58"	26'48"22"
4+50.00	25.00'	31.74'	18.05'	8'57"07"	35'45"29"
4+69.11	19.11'	24.31'	13.82'	6'50"35"	42'36"04"

P.V.I. Elev. = 1321.00 NO V.C.
 P.V.I. Elev. = 1320.60 NO V.C.
 P.V.I. Elev. = 1320.42 NO V.C.

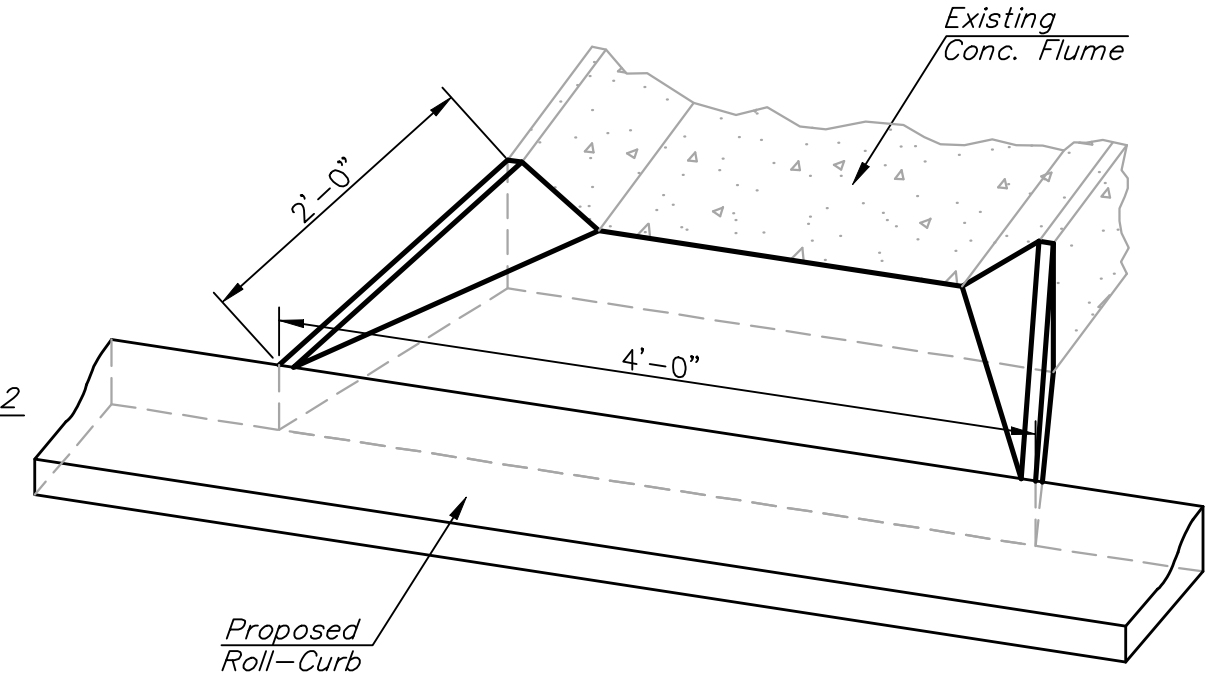
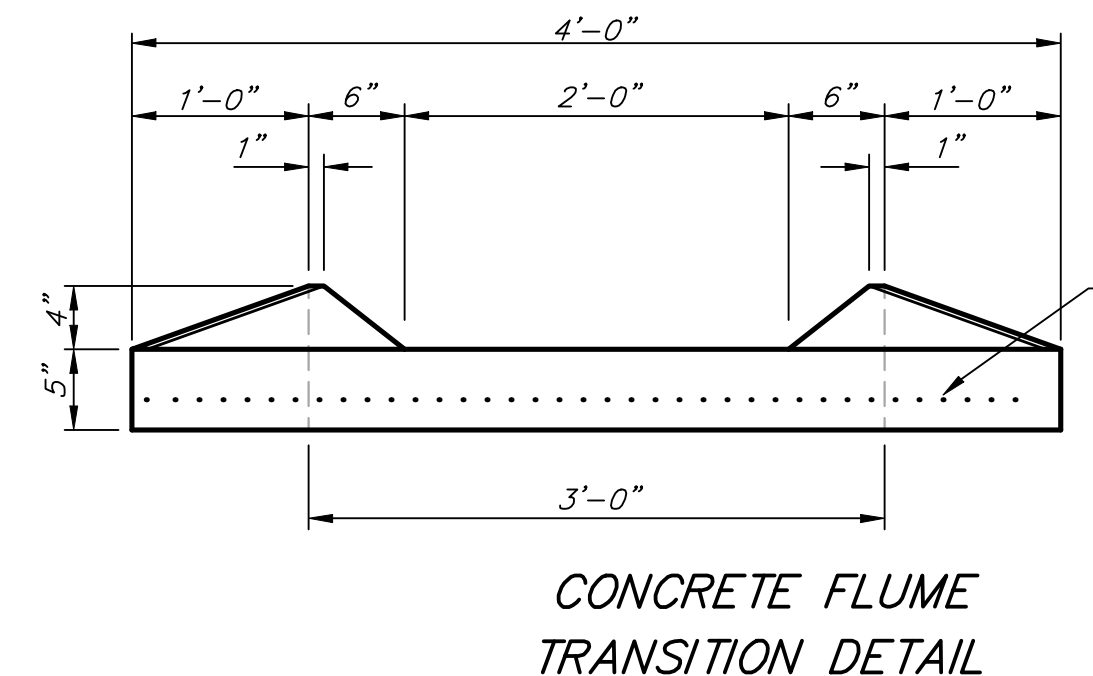

Roll Type Curb & Gutter To Be Constructed On The Pavement On This Sheet. Top Of Curb Elevation Are Given For Full Height Curb.

Baughman Mesa Verde Addition - Phase II
34th STREET
 STA. 3+67.13 TO STA. 7+41.53

Baughman Company, P.A. 315 Ellis St. Wichita, KS 67211 P 316-262-7771 F 316-262-0149
 ENGINEERING | SURVEYING | PLANNING | LANDSCAPE ARCHITECTURE

PROJECT NUMBER 472	DESIGN JAK	DRAWN JAK
REVISIONS:	APPROVED	DATE 5/13/08
SCALE Noted		5 OF 16
SHEET		

Mesa Verde Phase 2 Str 2 08-03-E075