

Sedgwick County East Yard Addition

Nies 4th Addition

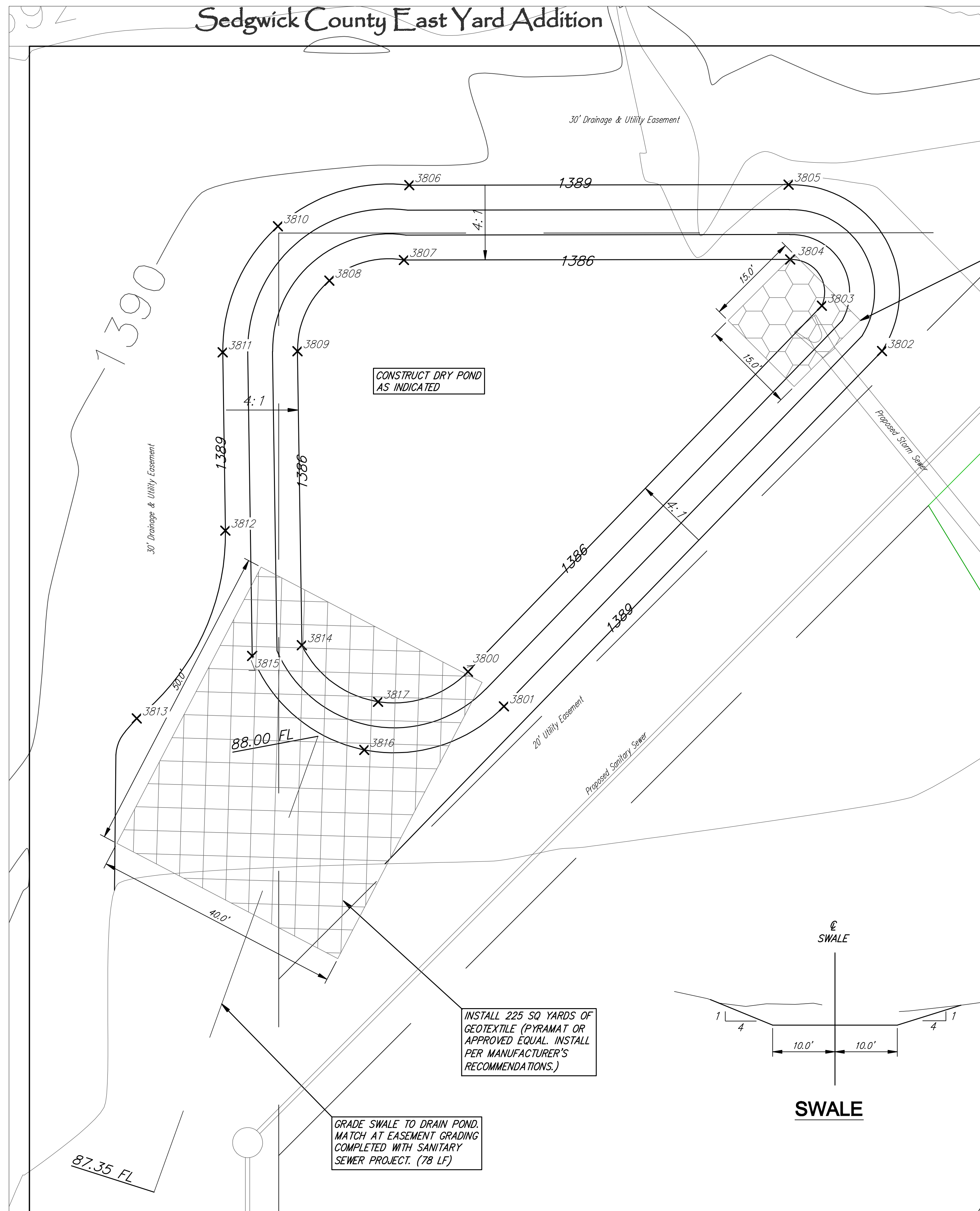

CONSTRUCT DRY POND AS INDICATED

INSTALL 25 SQ YARDS OF LIGHT STONE RIP-RAP.

INSTALL 225 SQ YARDS OF GEOTEXTILE (PYRAMAT OR APPROVED EQUAL. INSTALL PER MANUFACTURER'S RECOMMENDATIONS.)

GRADE SWALE TO DRAIN POND. MATCH AT EASEMENT GRADING COMPLETED WITH SANITARY SEWER PROJECT. (78 LF)

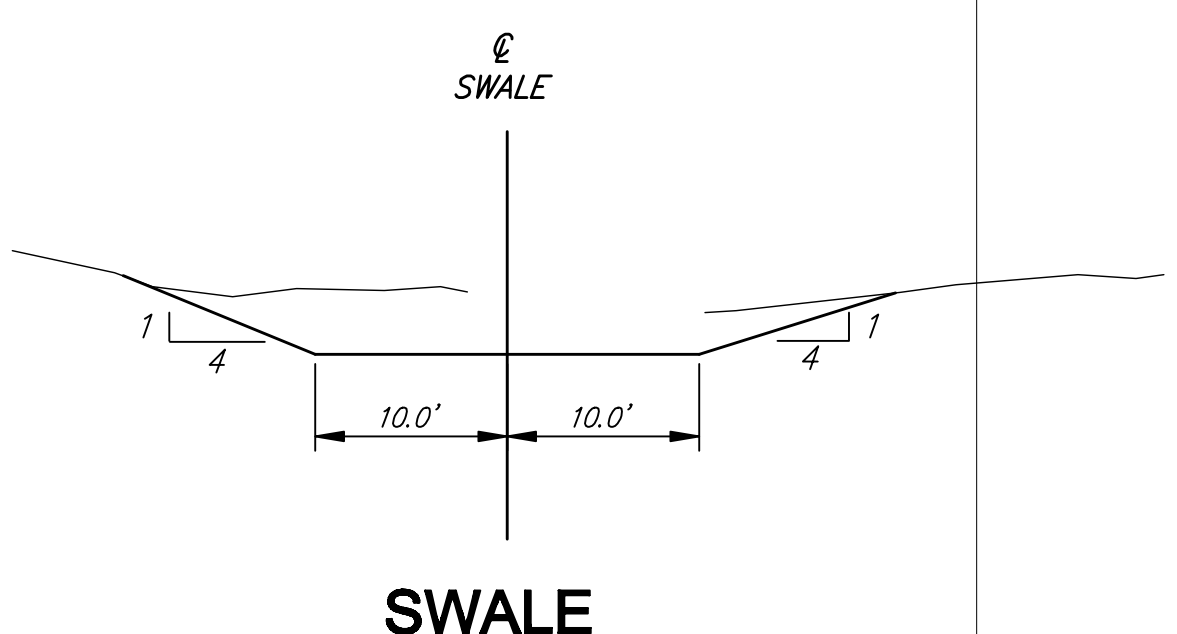

Point Table			
Point #	Northing	Easting	Description
3800	20337.04	20730.37	POND
3801	20331.48	20736.12	POND
3802	20388.48	20796.79	POND
3803	20395.76	20787.14	POND
3804	20403.18	20782.06	POND
3805	20415.18	20781.81	POND
3806	20415.10	20720.94	POND
3807	20403.10	20720.09	POND
3808	20399.79	20708.11	POND
3809	20388.46	20703.00	POND
3810	20408.51	20699.86	POND
3811	20388.28	20691.01	POND
3812	20359.67	20691.43	POND
3813	20329.55	20677.22	POND
3814	20341.28	20703.71	POND
3815	20339.56	20695.73	POND
3816	20324.49	20713.72	POND
3817	20332.22	20715.94	POND

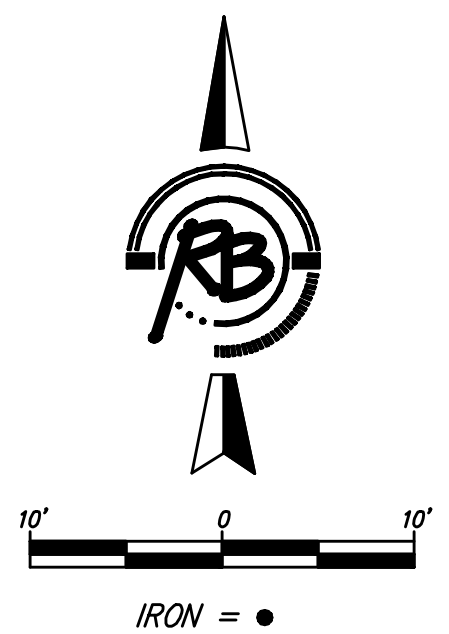

BRENTWOOD SOUTH 3rd ADDITION
Pond Plan
WICHITA, KANSAS



Ruggles & Bohm, P.A.
 Engineering, Surveying, Land Planning

224 North Main
 Wichita, Kansas 67203
 www.rbanessa.com

(913) 264-8288
 (913) 264-8281 fax
 E-mail: info@rbanessa.com

DATE: Mar. 5, 2008
 TIME: 9
 OF: 18

PROJECT FILE: Paving {POND PLAN}

PROJECT NUMBER: 472-84656

DATE: May 13, 2008