

FHWA REGION NO.	STATE	PROJECT NO.	FISCAL YEAR	SHEET NO.	TOTAL SHEETS
7	KANSAS	87N-0378-01	2008	38a	72

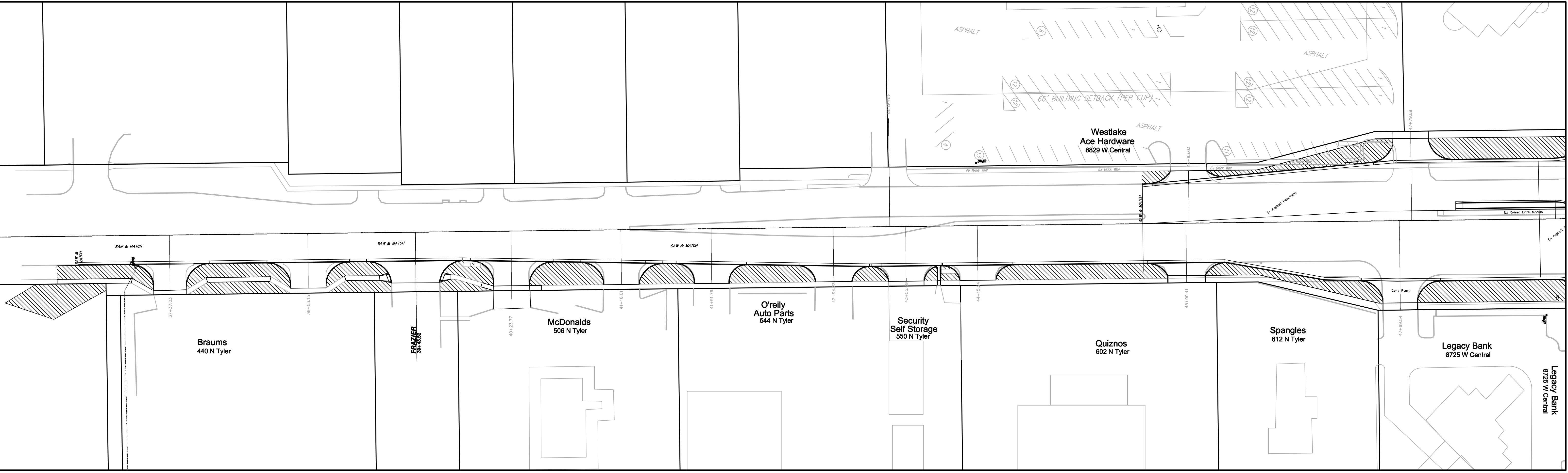
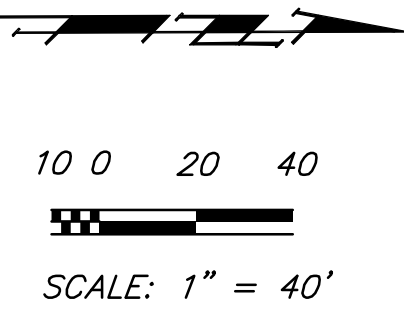

Drawing File: E:\eng\central and tyler intersection\land\base.dwg

Design: T. Azlere  
 Drawn:  
 Approved: J. F. Bradley  
 Scale: 1:20

Project No. 05-10E393 CAPITAL IMPROVEMENT PROJECT  
**CENTRAL & TYLER INTERSECTION  
 SODDING PLAN**  
 PAVEMENT, STORM WATER SEWER, TRAFFIC CONTROL IMPROVEMENTS

**Baughman Company, P.A.**  
 315 Ellis St. Wichita, KS 67211 P 316-262-7271 F 316-262-0149  
**Baughman** ENGINEERING | SURVEYING | PLANNING | LANDSCAPE ARCHITECTURE

MAY 2008  
 SHEET  
**38a**  
 OF  
 72