

**EXPANSION JOINT**

NOTE: Extra Thickness to be Subsidiary to Price of Square Yards Pavement

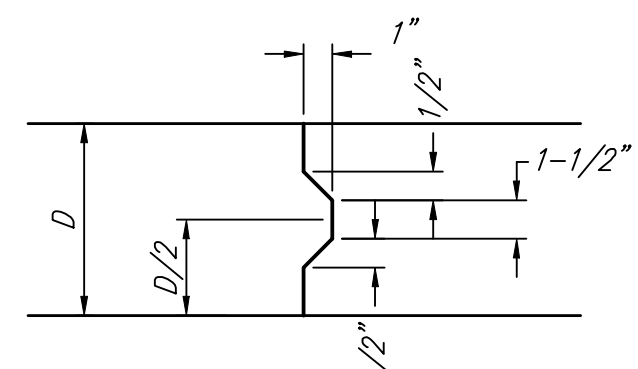

**KEYWAY DETAIL**

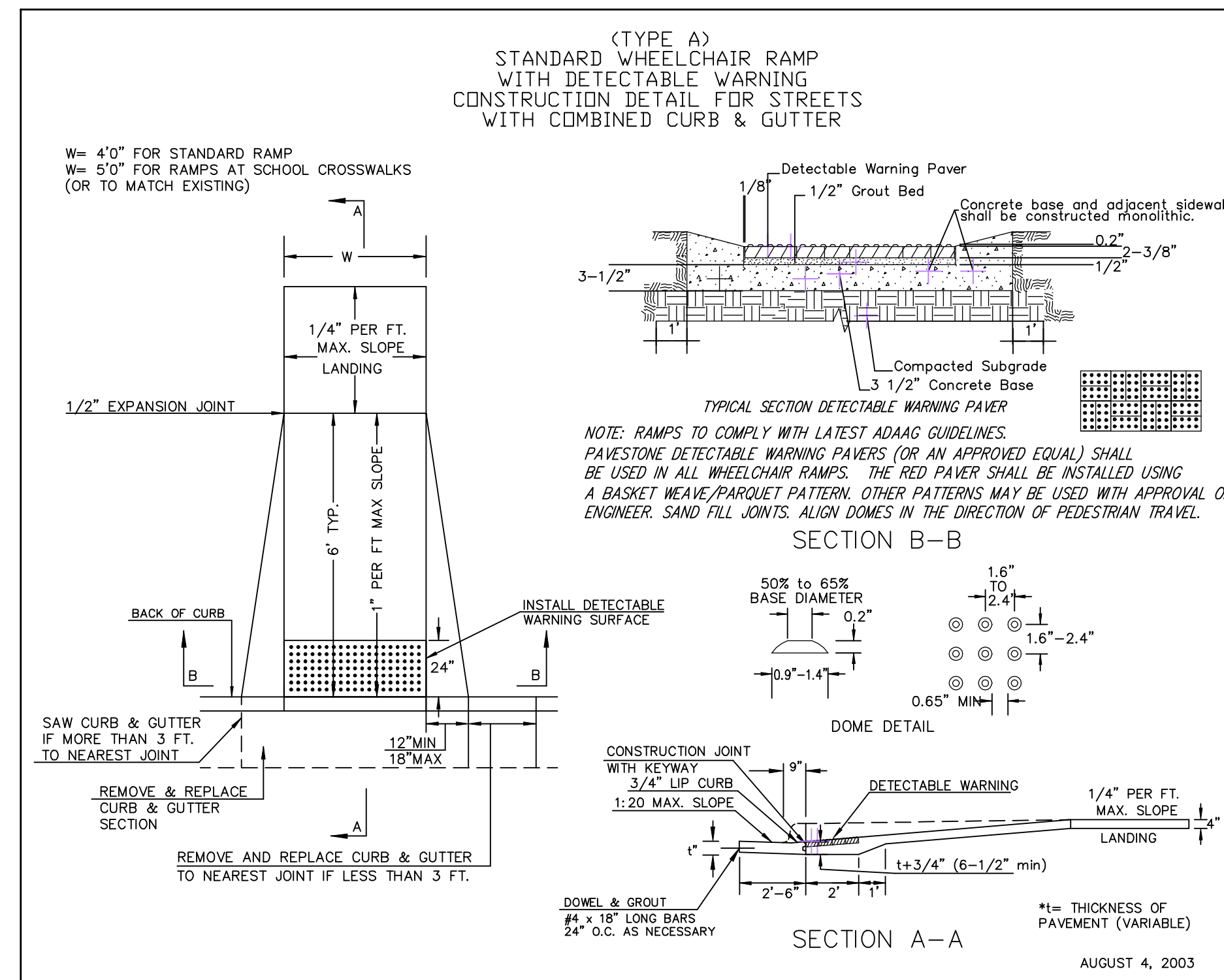

**WHEELCHAIR RAMP DETAIL**

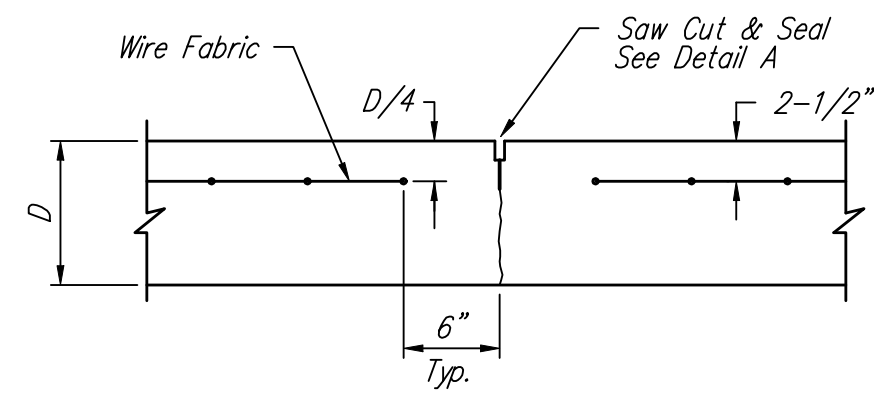

**CONTRACTION JOINT DETAIL (C.J.)**

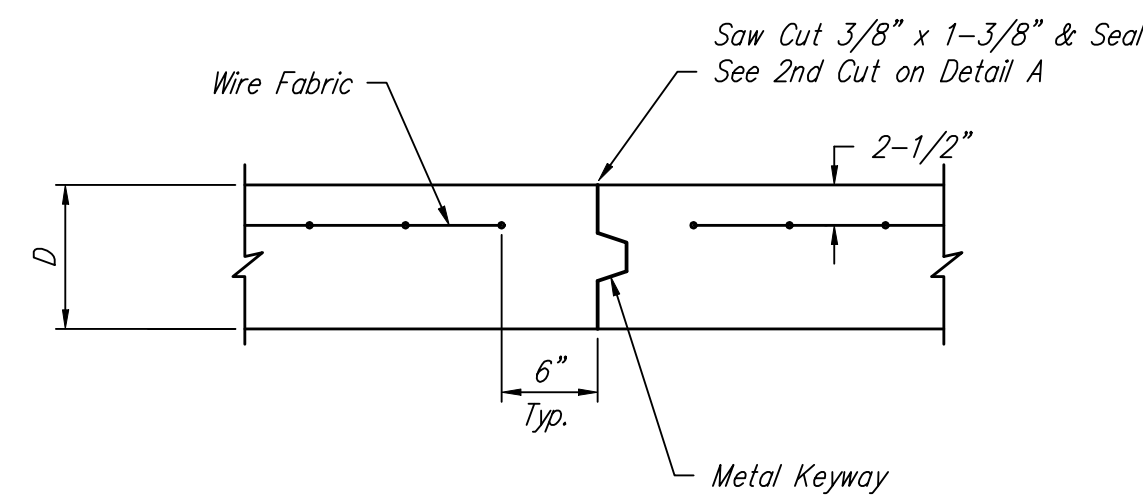

**OPTIONAL CONTRACTION JOINT (CONSTRUCTION JOINT)**

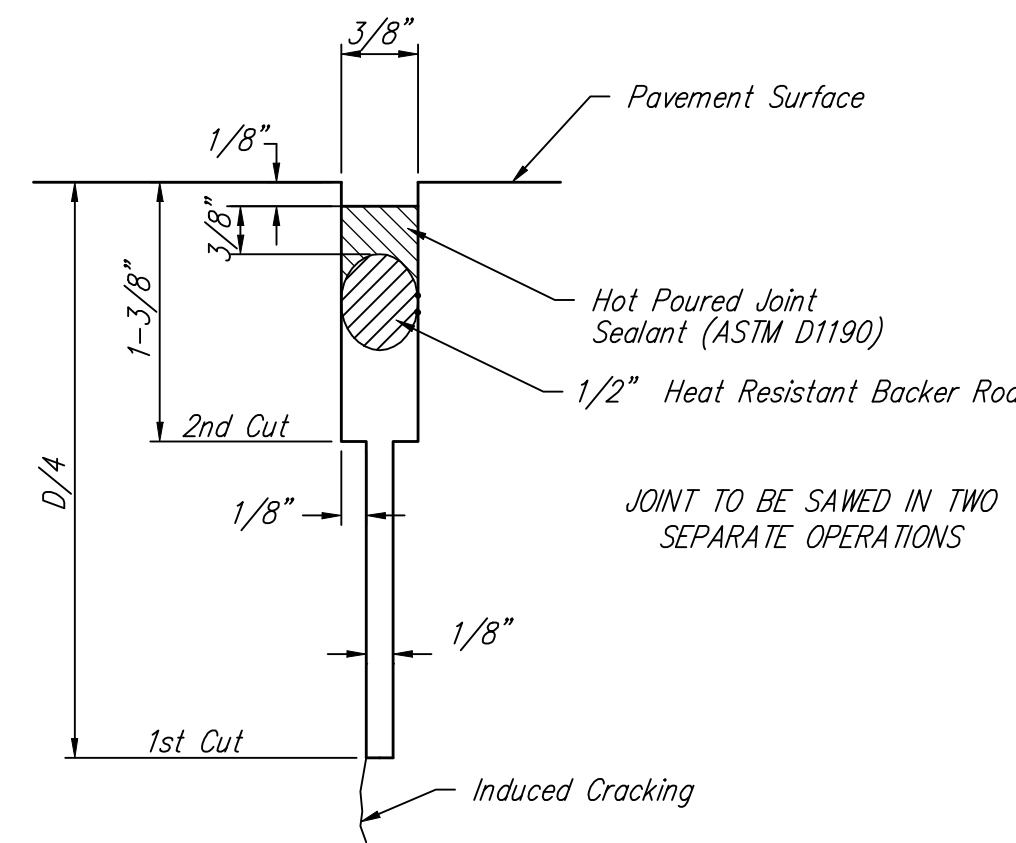

**SAW JOINT DETAIL "A"**

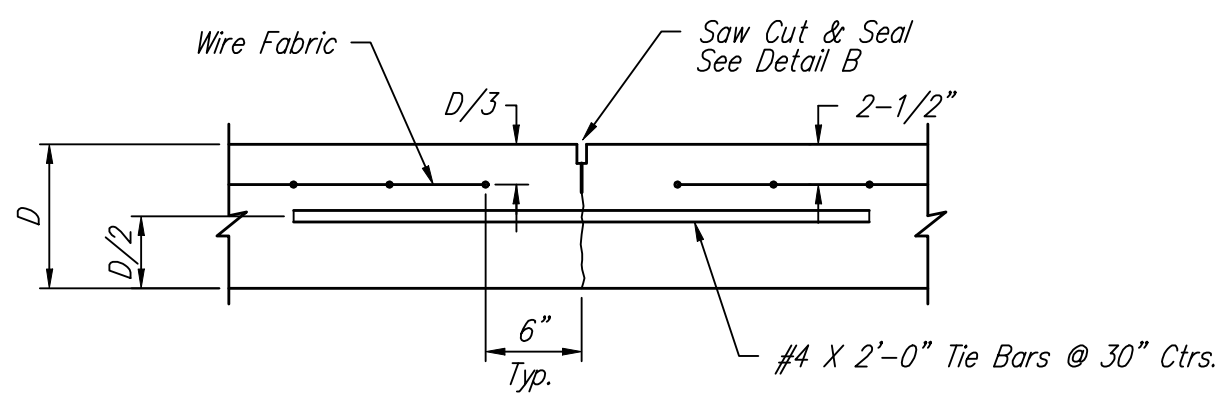

**LONGITUDINAL JOINT DETAIL (L.J.)**

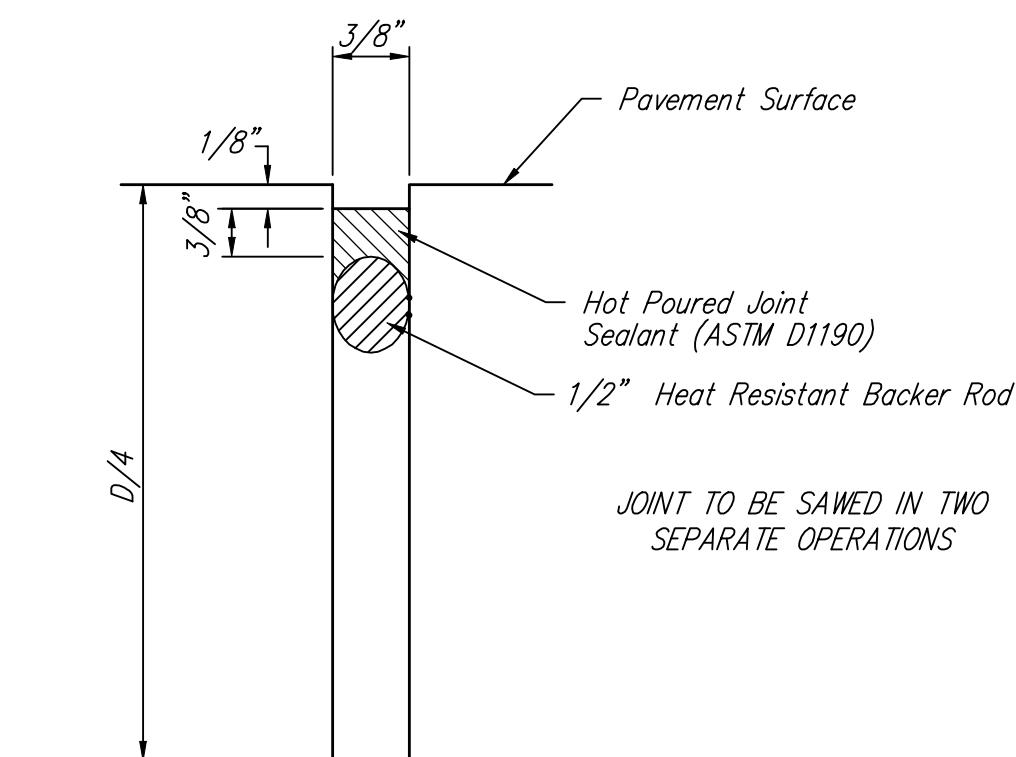

**SAW JOINT DETAIL "B"**

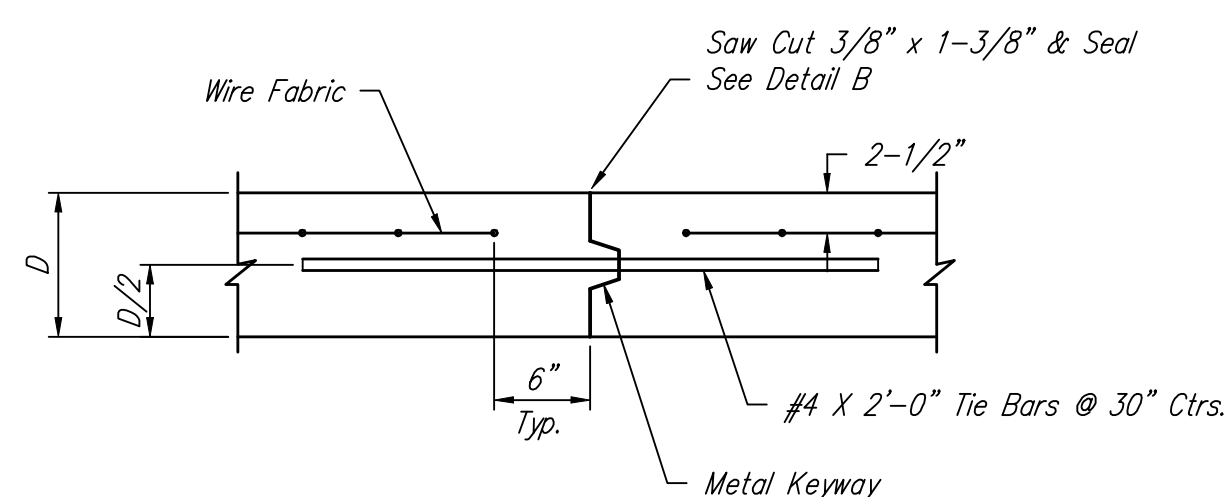

**OPTIONAL LONGITUDINAL JOINT DETAIL (L.J.) (CONSTRUCTION JOINT)**

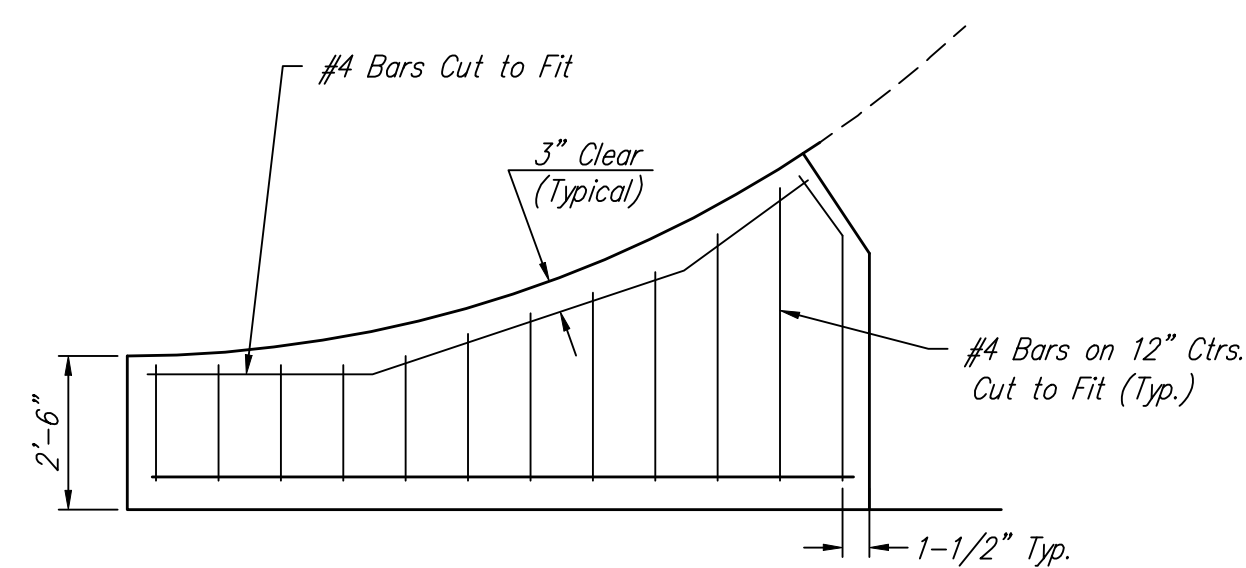

**WING REINFORCING DETAIL**

		<b>MISCELLANEOUS DETAILS</b>	
		<small>Baughman Company, P.A. 315 Ellis St. Wichita, KS 67211 P 316-262-7271 F 316-262-0149 ENGINEERING   SURVEYING   PLANNING   LANDSCAPE ARCHITECTURE</small>	
PROJECT NUMBER	DESIGN STAFF	DRAWN STAFF	
REVISIONS:	APPROVED	DATE	8/11/08
	SCALE	NONE	
	SHEET	<b>6 OF 34</b>	