

GENERAL NOTES:
MATERIAL: Use ASTM A615, Grade 60 reinforcing bars, except for the loop bars (d_1, d_2 and d_3).
 The loop bars (d_1, d_2 and d_3) shall be $\frac{3}{4}$ " smooth steel bars with a minimum yield of 60 ksi, a tensile strength of not less than 1.25 times the yield strength but a minimum of 80 ksi, a minimum 14% elongation in 8 inches, and passing a 180 degree bend test using a 3.5" D pin bend diameter. The loops shall be installed with-in $\frac{1}{8}$ " of the plan dimensions.
 Use air-entrained concrete with $f'c = 5,000$ p.s.i.
SECTION: The section furnished must generally comply with dimensions shown. Requests for minor variations in section geometry and attachments may be submitted to the Engineer for approval.
LIFTING SLOTS: Lifting slots shall be constructed where specified on the plans to facilitate the drainage of water after installation on the roadway.
TEMPORARY CONCRETE SAFETY BARRIER: Furnishing and placing of all materials when required and all labor and equipment required to position the temporary barrier shall be included in the Contract unit price bid for "Concrete Safety Barrier (Type F3)(Temporary)". Any relocation of the barrier required for the project shall be paid in accordance with the Special Provisions under the bid item "Concrete Safety Barrier (Type F3) (Temporary-Relocate)". Unless otherwise noted on the Plans, the Temporary Concrete Safety Barrier shall become the property of the Contractor and shall be removed from the site upon acceptance of the completed project. Approximate weight of one unit equals 2.7 tons.
SURFACE PREPARATION: Barrier shall be placed on a paved surface. All loose dirt and sand shall be removed from the roadway surface just prior to placement of the barrier.
MARKING: The left end (*) of each barrier shall be permanently marked by stamping or forming into the barrier the following information:
 - Type F3
 - Manufacturer code (as specified by KDOT Bureau of Const. & Maint.)
 - Date manufactured (month and year)

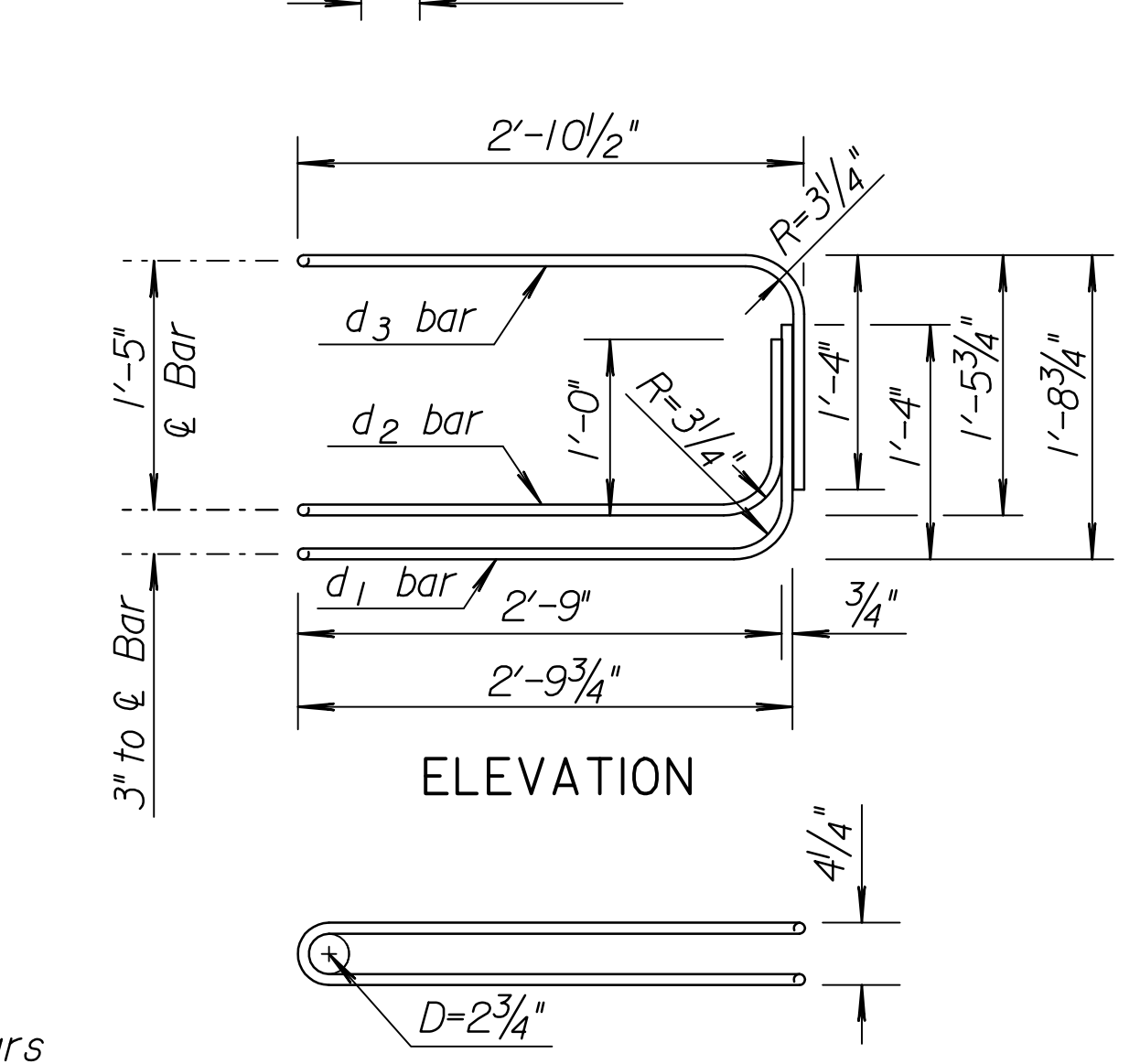
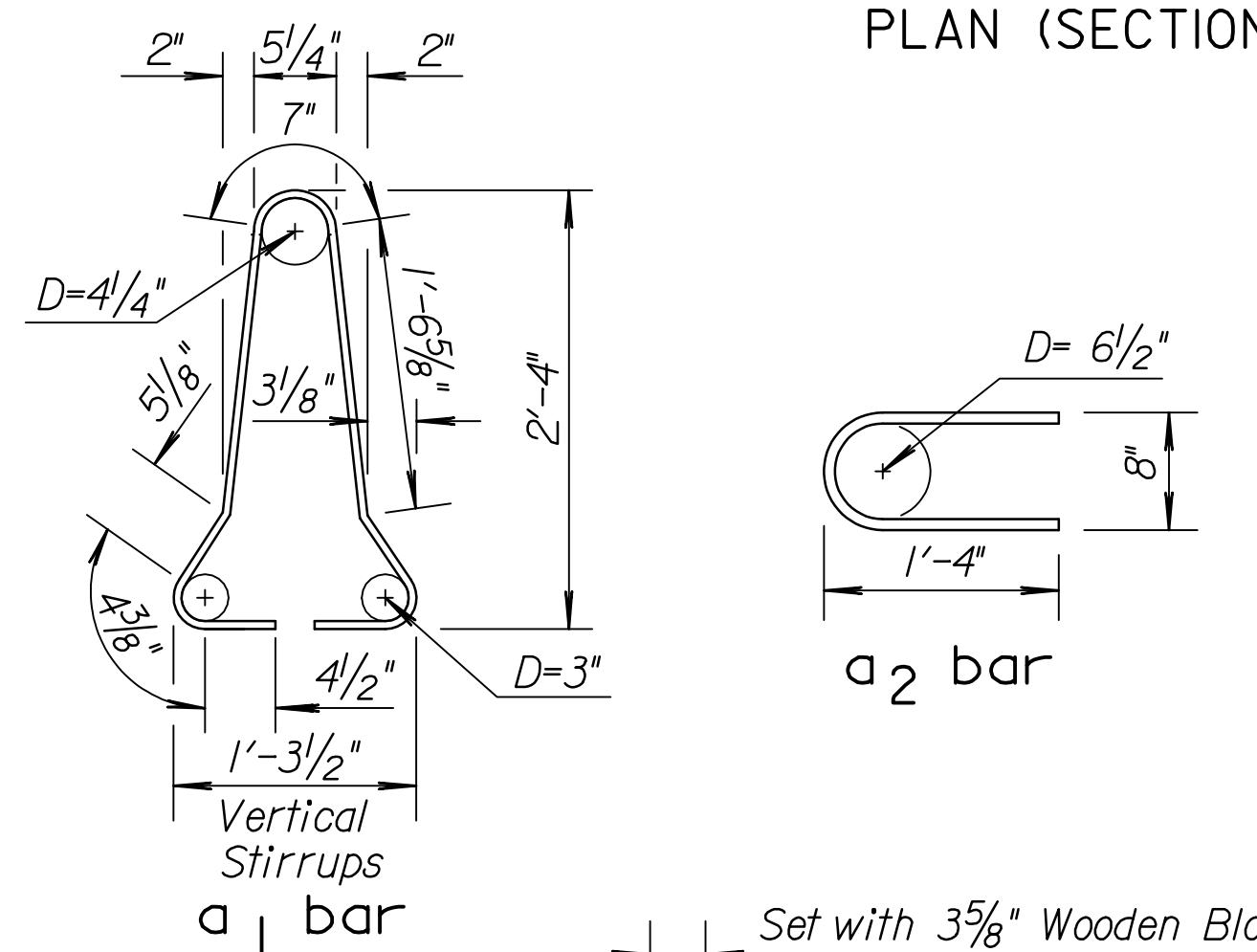
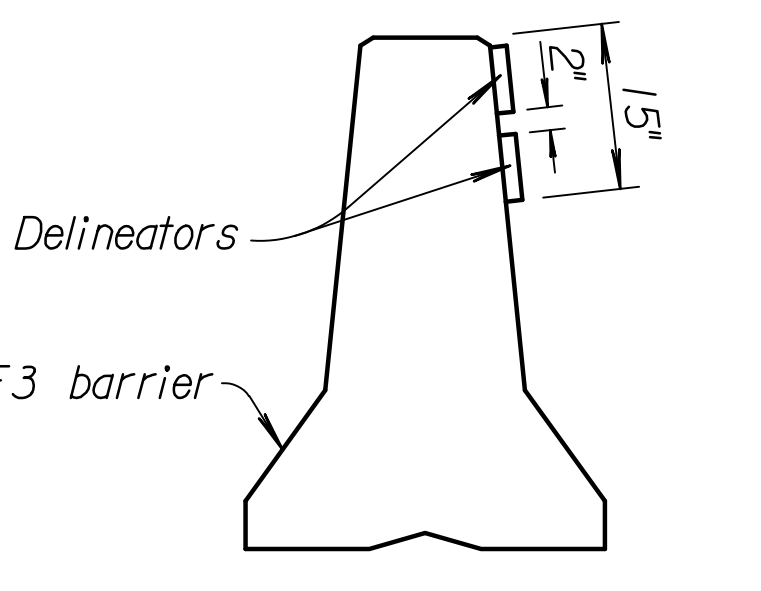
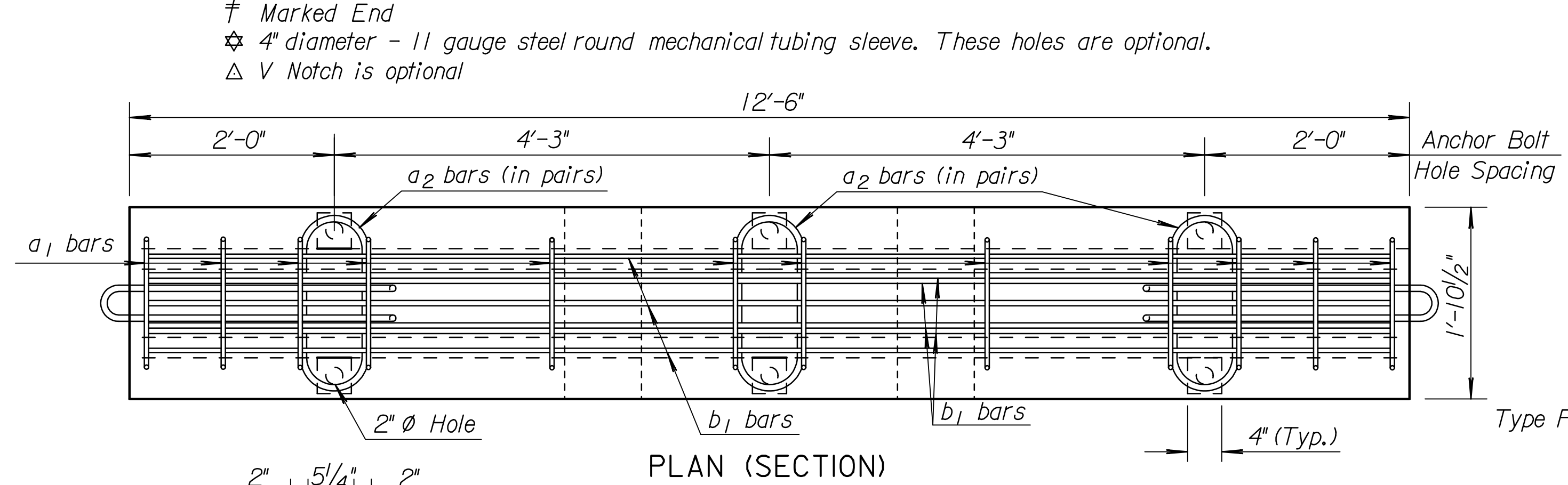
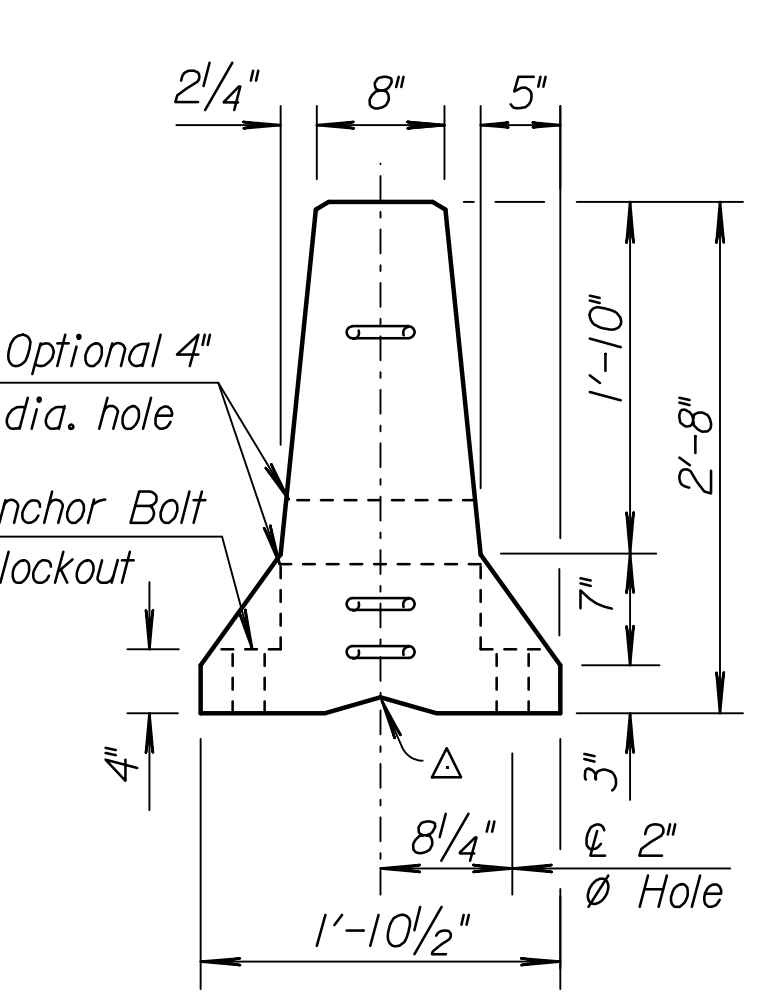

DELINEATOR DETAILS

Per 12'-6" Barrier Section

REINFORCING A615 Gr. 60					
Bar	Bar Size	Shape	No. of Bars	Length Ft.	Weight Lbs.
d_1	#4	U	12	6'-0"	48.1
d_2	#6	C	6	2'-11"	26.3
b_1	#5	—	7	12'-2"	88.8

LOOP ASSEMBLY					
Bar	Bar Size	Shape	No. of Bars	Length Ft.	Weight Lbs.
d_1	#6	U	2	8'-5"	25.3
d_2	#6	U	2	7'-7"	22.8
d_3	#6	U	2	8'-6"	25.5

Concrete Quantity = 1.3 C.Y.
 (Dimensions are out to out of bars unless otherwise noted.)

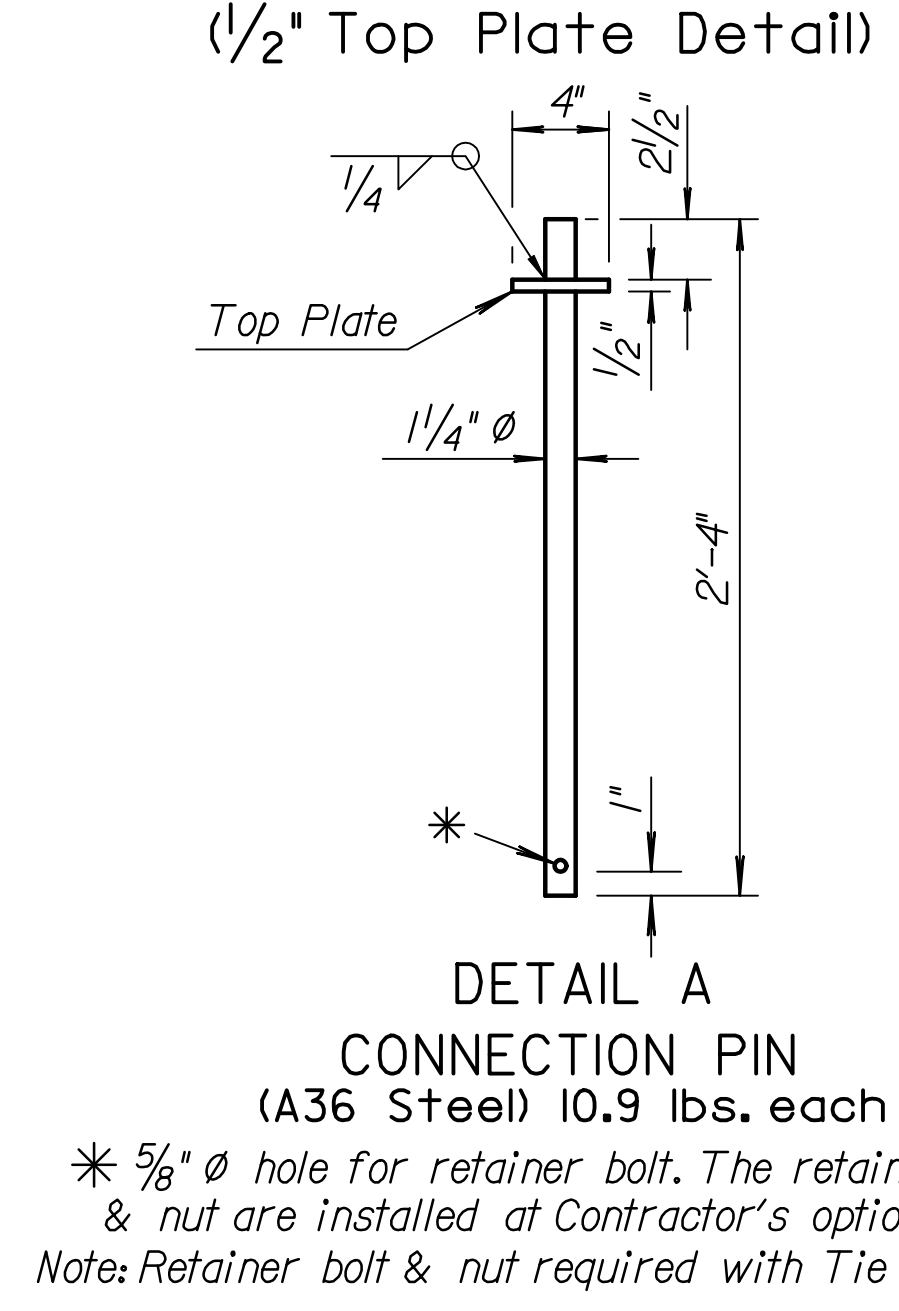
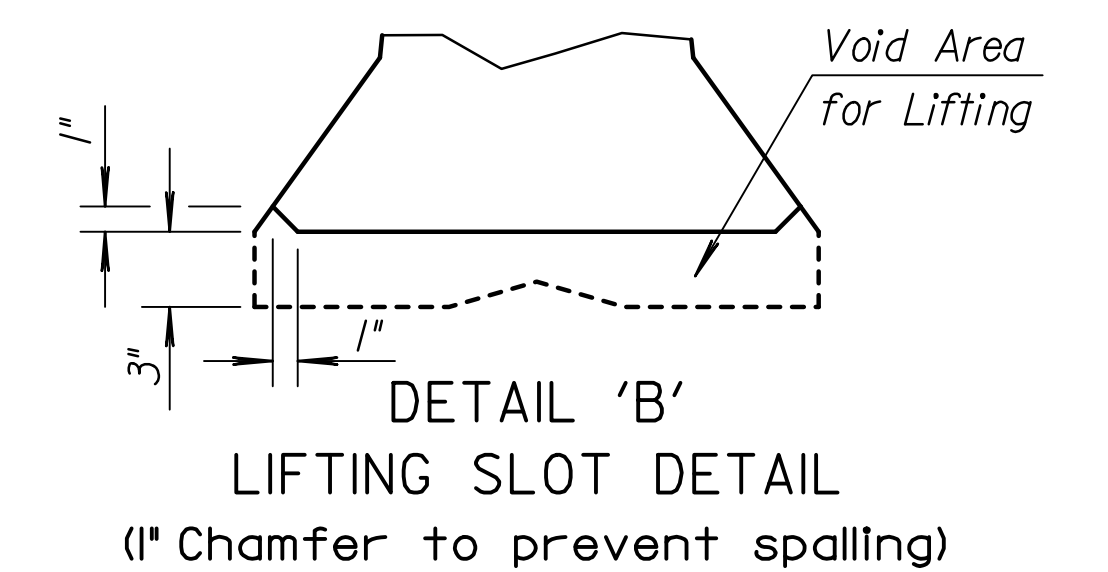

DETAILS OF BARRIER CONNECTION

LOOP BAR ASSEMBLY (Marked end shown, Invert for other end) (Material as stated in General Notes)

NOTE: At no time shall the barriers be lifted, moved, etc. by use of the loop bars: d_1, d_2 or d_3 .

3					
2	2-6-07	Revised additional sheets note	S.W.K.	J.O.B.	
1	1-10-07	Rev. layout & notes, add Delineation	S.W.K.	J.O.B.	
NO.	DATE	REVISIONS	BY	APP'D	

KANSAS DEPARTMENT OF TRANSPORTATION

TEMPORARY CONCRETE SAFETY BARRIER TYPE F3

RD622

DESIGNED	TRACED	QUANTITIES	APP'D
CK.	CK.	CK.	James O. Brewer
DESIGN CK.	DETAIL CK.	QUAN. CK.	TRACE CK.
			Tracy King