

POWER POLE DETAILS

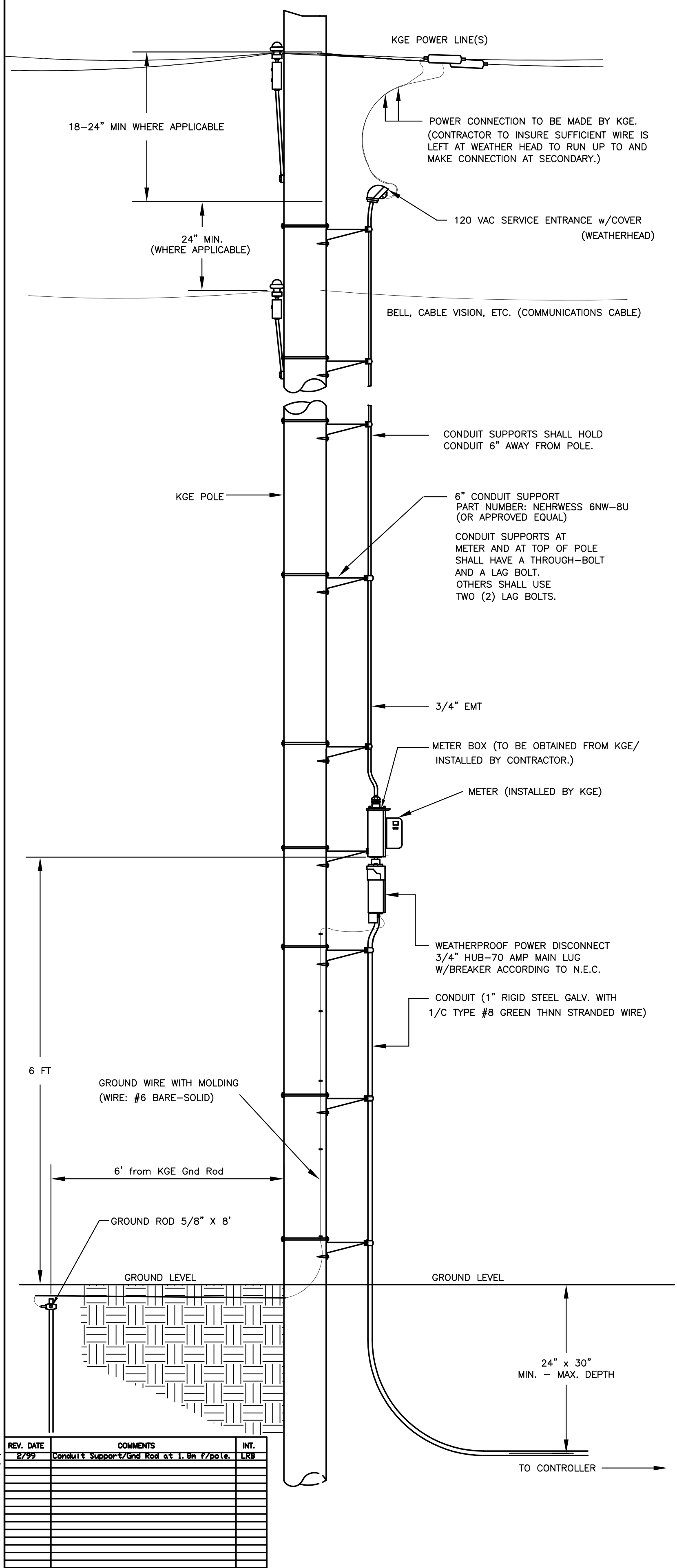

SPANWIRE ASSEMBLY DETAILS

1. MAX. SAG = 5% OF SPAN.
2. STANDARD BACKRAKE = 1.5'
3. HEIGHT OF STRAIN WIRE HOOK-UP TO BE DETERMINED BY FIELD ENGINEER. TRAFFIC SIGNAL CABLE TO BE SECURED TO STRAIN (SPAN) WIRE WEATHERABLE NYLON CABLE HANGERS (12" CTR.) DETAIL 'B'
4. TETHER CLAMP TO BE DESIGNED TO RELEASE UNDER 'HIGH WIND LOAD' TO PERMIT SIGNAL 'FREE SWING'.

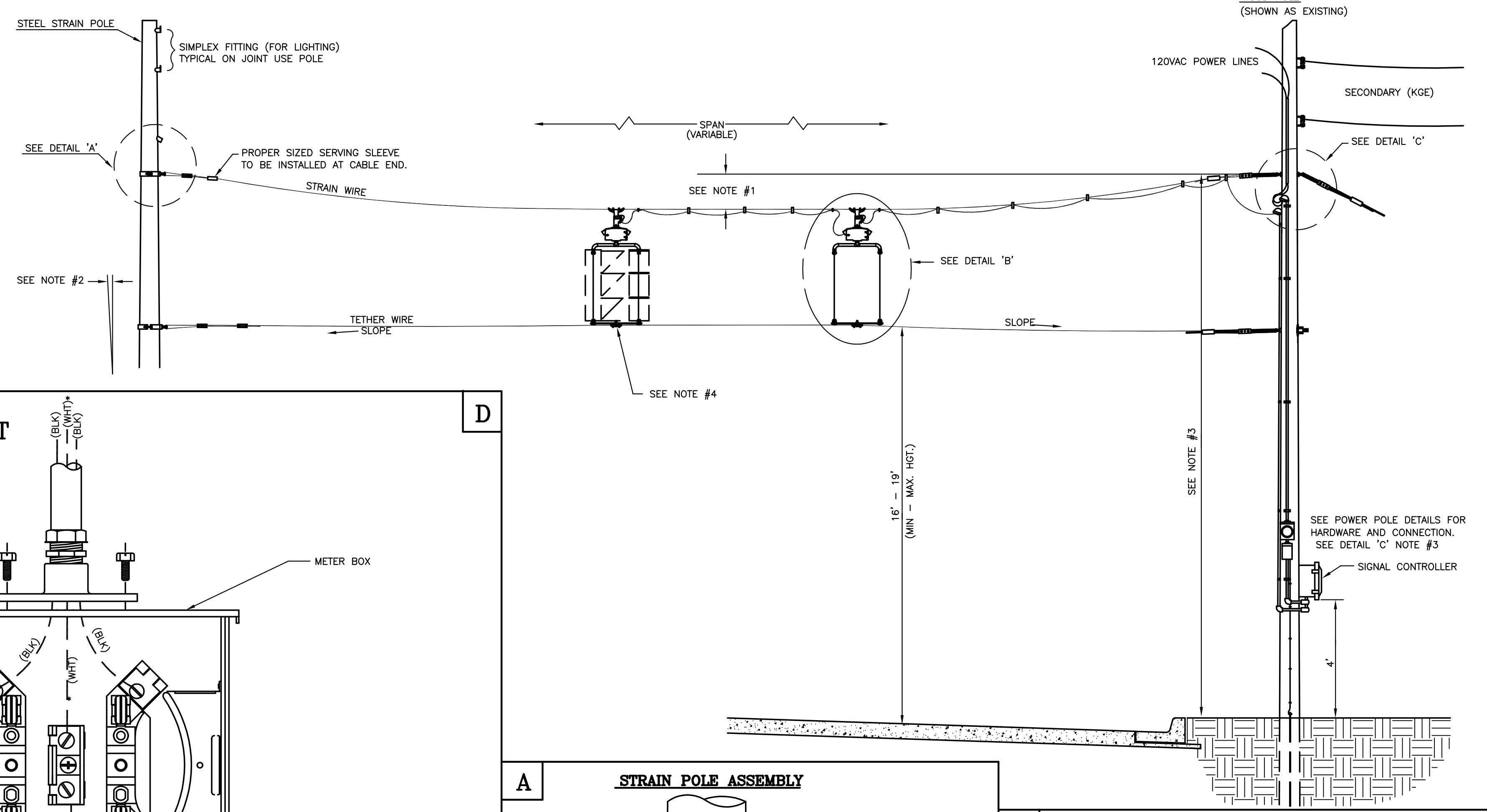

METER BOX & POWER DISCONNECT DETAILS

NOTE:
• TO BE MARKED WITH WHITE TAPE

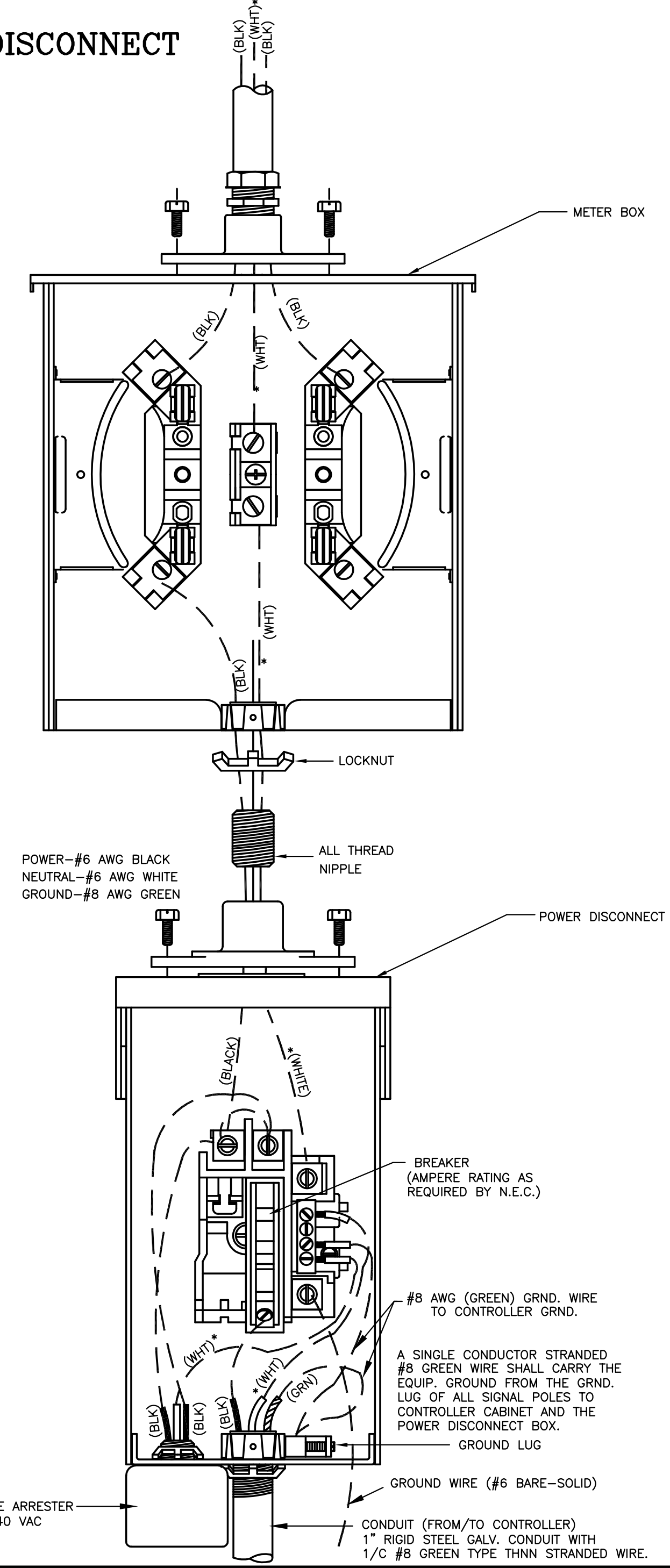

A STRAIN POLE ASSEMBLY

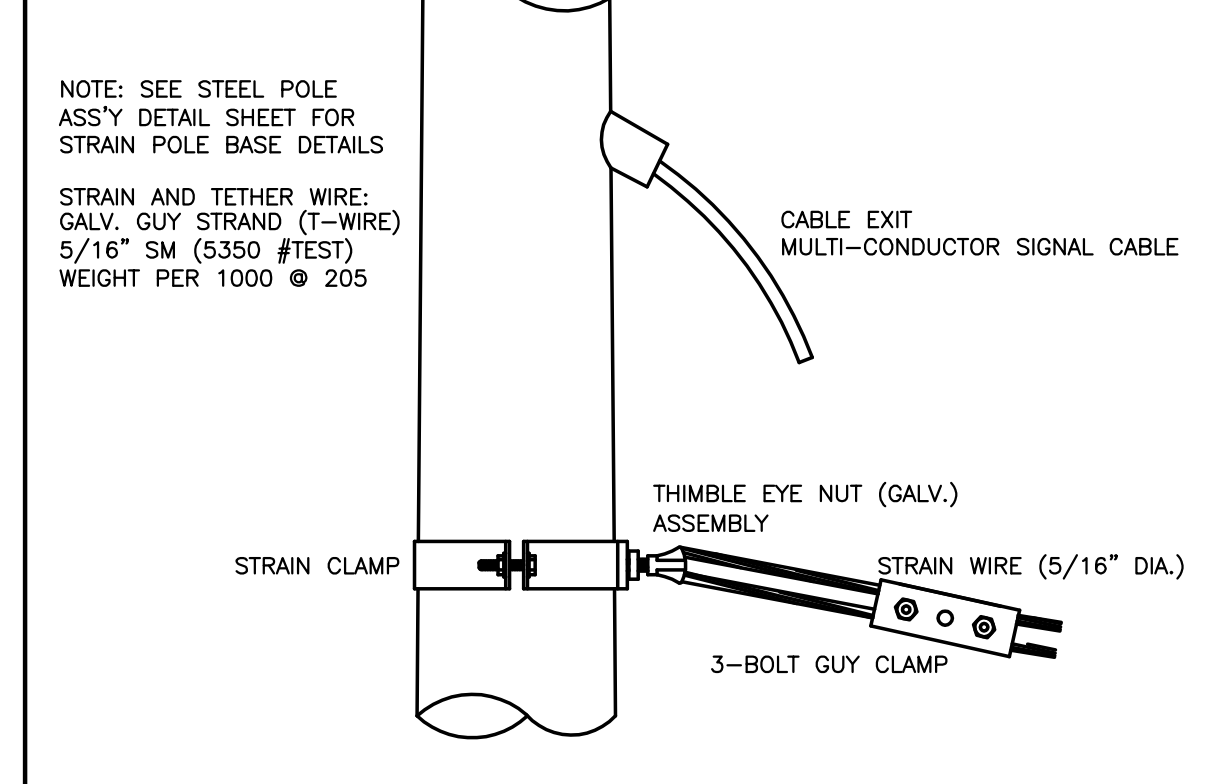

B SIGNAL BRACKET ASSEMBLY DETAILS

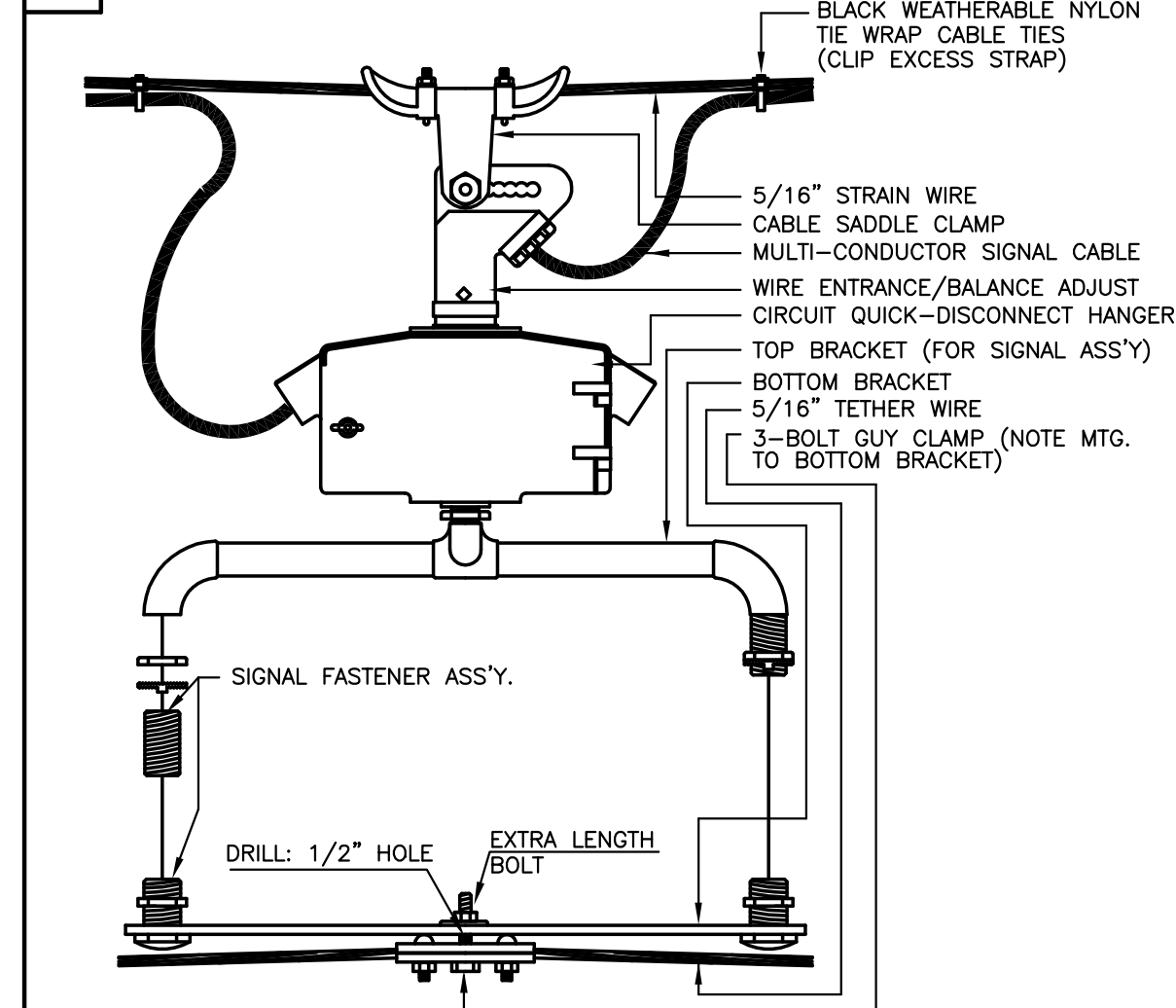

C WOOD POLE ASSEMBLY DETAILS KGE POLE EXCLUDED

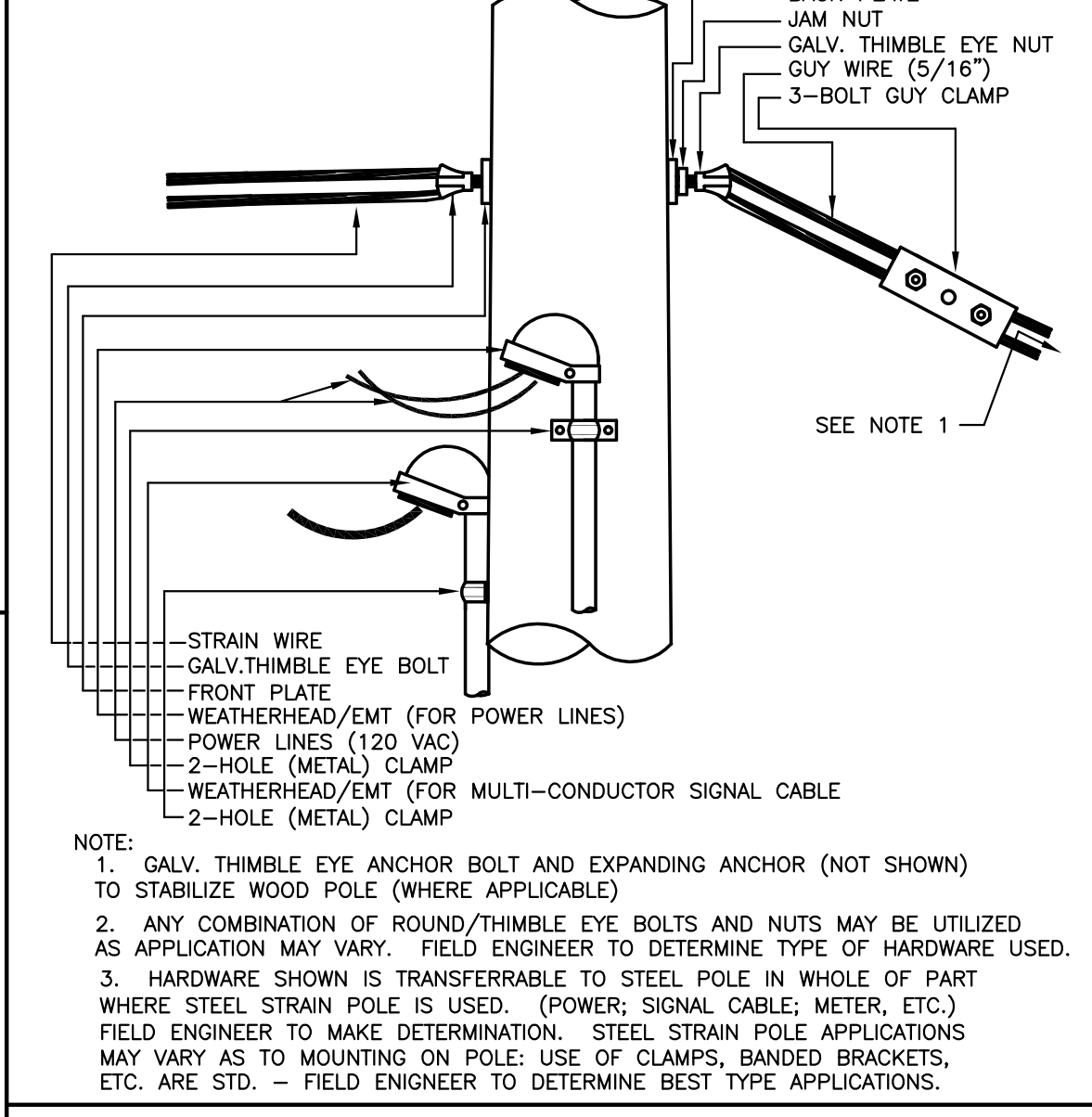

NOTE:
1. GALV. THIMBLE EYE ANCHOR BOLT AND EXPANDING ANCHOR (NOT SHOWN) TO STABILIZE WOOD POLE (WHERE APPLICABLE)
2. ANY COMBINATION OF ROUND/THIMBLE EYE BOLTS AND NUTS MAY BE UTILIZED AS APPLICATION MAY VARY. FIELD ENGINEER TO DETERMINE TYPE OF HARDWARE USED.
3. HARDWARE SHOWN IS TRANSFERABLE TO STEEL POLE IN WHOLE OR PART WHERE STEEL STRAIN POLE IS USED. (POWER; SIGNAL CABLE; METER, ETC.) FIELD ENGINEER TO MAKE DETERMINATION. STEEL STRAIN POLE APPLICATIONS MAY VARY AS TO MOUNTING ON POLE: USE OF CLAMPS, BANDED BRACKETS, ETC. ARE STD. - FIELD ENGINEER TO DETERMINE BEST TYPE APPLICATIONS.

T. MASON, TRAFFIC ENGINEER, 2/1/97. FILE: 01 - PPSP-DTL

REV.	DATE	COMMENTS	INT.
02/99		Conduit Support 1\"/>	

J:\Civil\04221\dwg\details\PPSP-DTL.dwg 06/12/2007 05:22:00 AM CST

PROJECT DESCRIPTION
POWER POLE AND SPAN POLE ASSEMBLY DETAILS

PROJECT NUMBER
87 N-0357-01

DRAWN BY: T.M. APPROVED BY: L.B.
DATE: FEB. 96 DATE: 2/26/99

CITY OF WICHITA
DEPARTMENT OF PUBLIC WORKS

DIVISION OF TRAFFIC ENGINEERING SCALE: 121/185
PAUL GUNZELMAN, P.E. TRAFFIC ENGINEER NO SCALE SHEET / OF