

PLAN

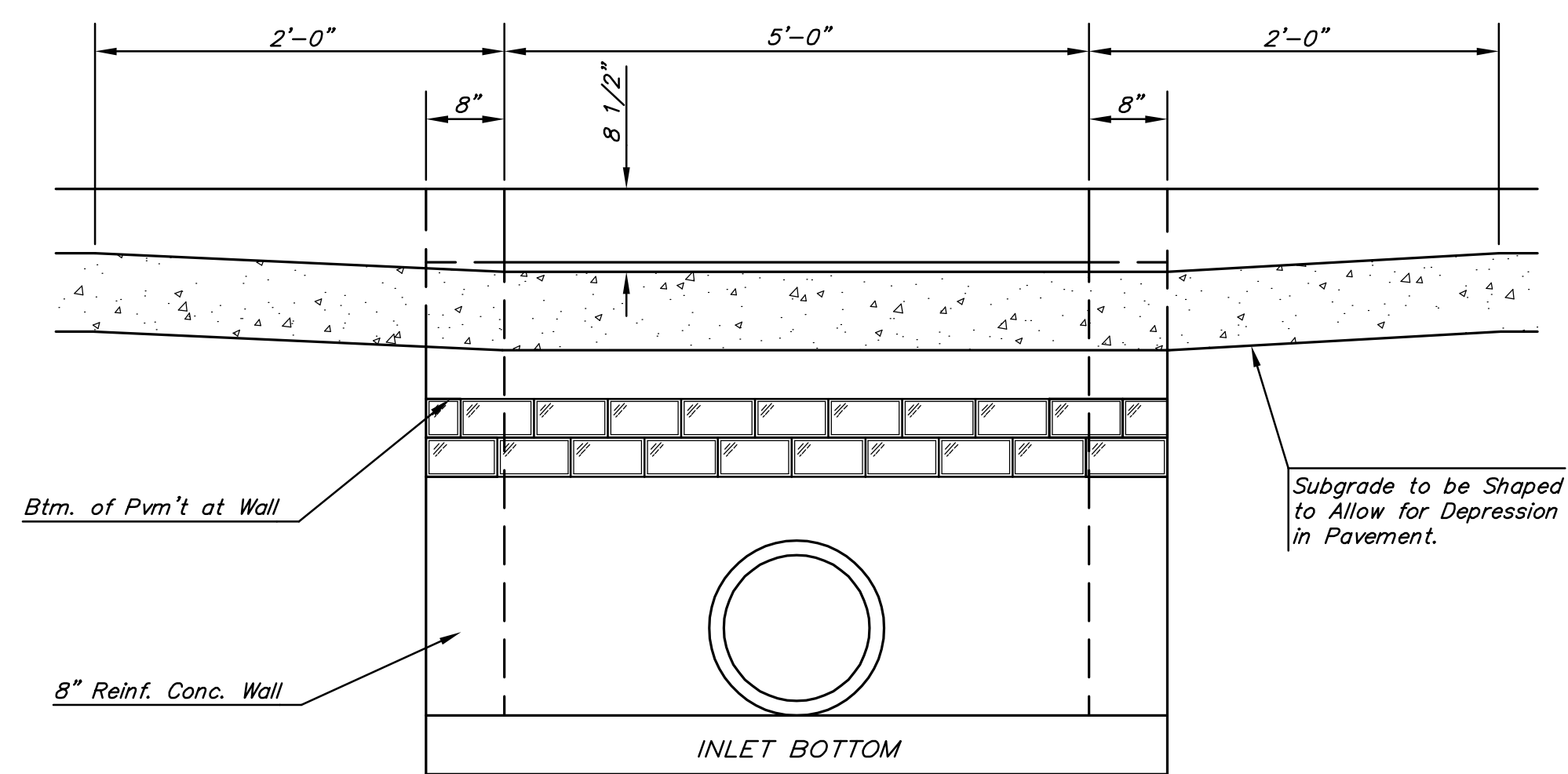

SECTION C-C

STEEL SCHEDULE

BAR	a_1	a_2	a_3	b_1				b_2	b_3	b_4	Wt. Lbs.	
NUMBER	4	4	2	1	3	5	7	9	6	1		
SIZE	#4	#4	#4	#4	#4	#4	#4	#4	#4	#6		
LENGTH	W=4'-4"	5'-7"	6'-7"	4'-0"	6'-1"	-	-	-	1'-9"	6'-2"	4'-8"	60±
	W=5'-4"	7'-7"	8'-7"	5'-0"	6'-1"	-	-	-	1'-9"	6'-2"	4'-8"	81±
	W=6'-4"	9'-7"	10'-7"	6'-0"	-	6'-1"	-	-	1'-9"	6'-2"	4'-8"	101±
	W=7'-4"	11'-7"	12'-7"	7'-0"	-	-	6'-1"	-	1'-9"	6'-2"	4'-8"	121±
	W=8'-4"	13'-7"	14'-7"	8'-0"	-	-	-	6'-1"	1'-9"	6'-2"	4'-8"	141±

Note: a_3 Bars to be Placed Approx. 2" Below Top of Inlet Cover.

W	PRE-CAST TOP SIZE	PIPE SIZE	CU. YD. CONC.
4'-4"	3'-8" 6'-4" 7 1/2"	21" & SMALLER	0.38±
5'-4"	4'-8" 6'-4" 7 1/2"	24" & 30"	0.51±
6'-4"	5'-8" 6'-4" 7 1/2"	36" & 42"	0.64±
7'-4"	6'-8" 6'-4" 7 1/2"	48" & 54"	0.77±
8'-4"	7'-8" 6'-4" 7 1/2"	60" & 66"	0.90±

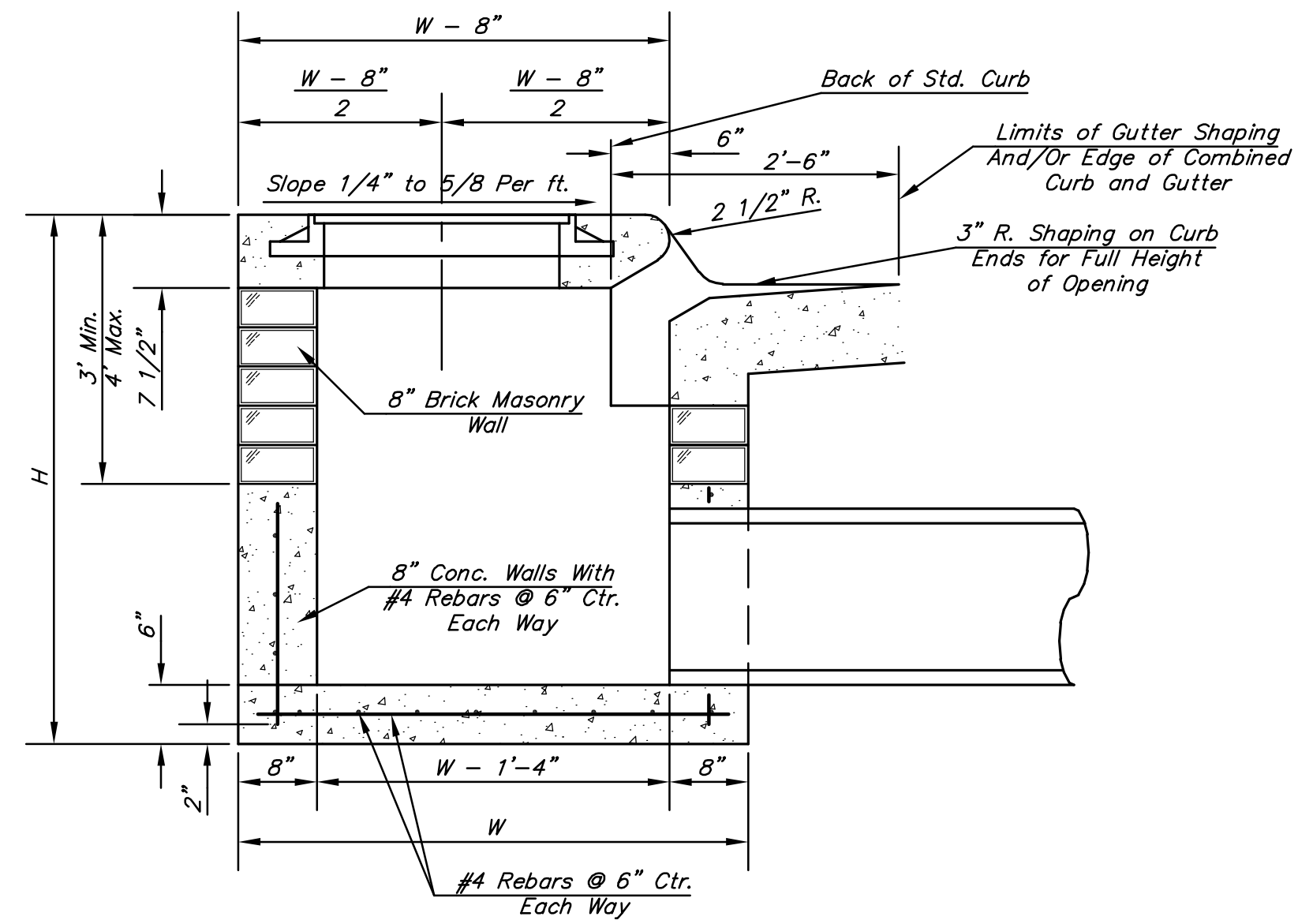

SECTION A-A

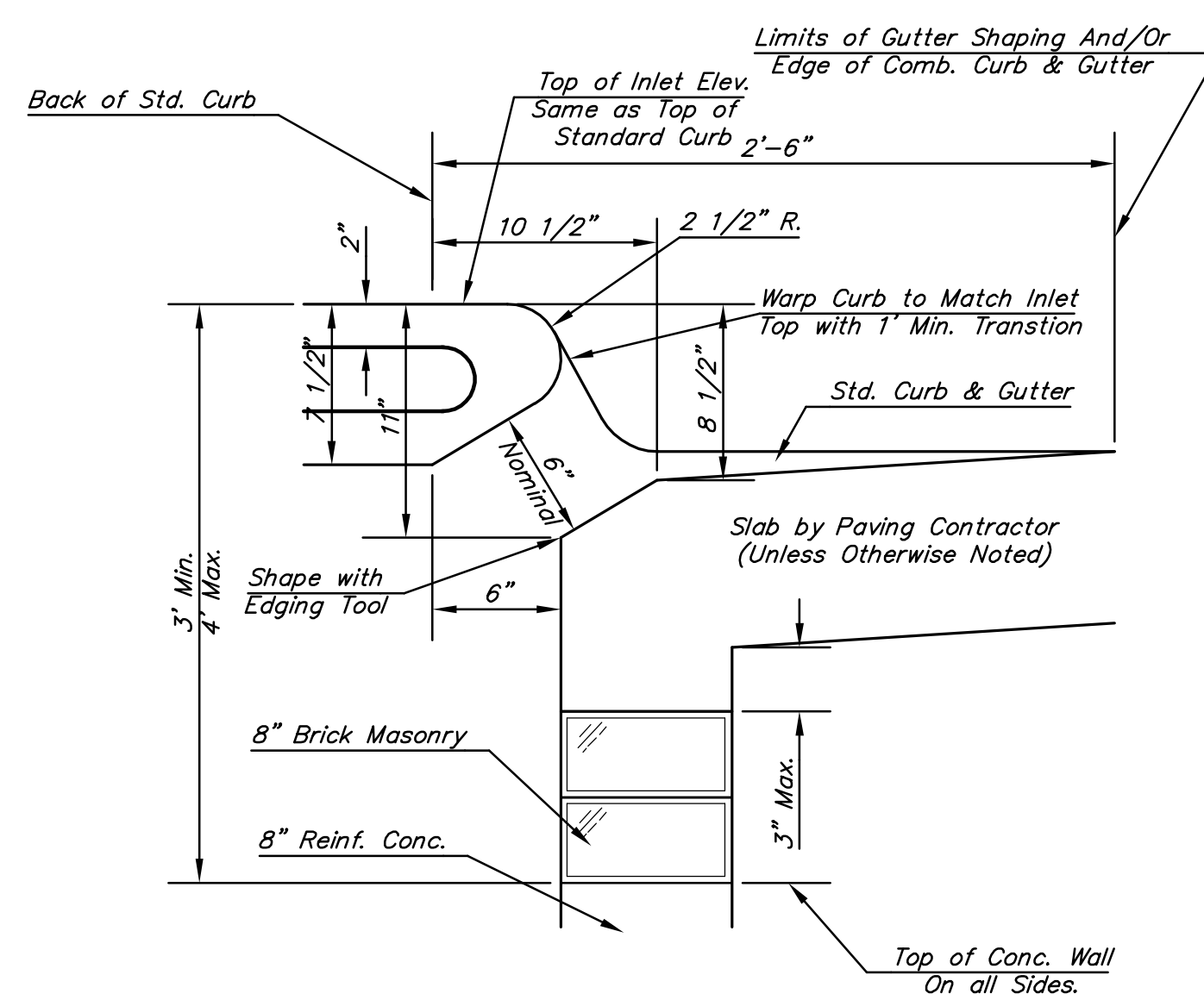

SECTION B-B

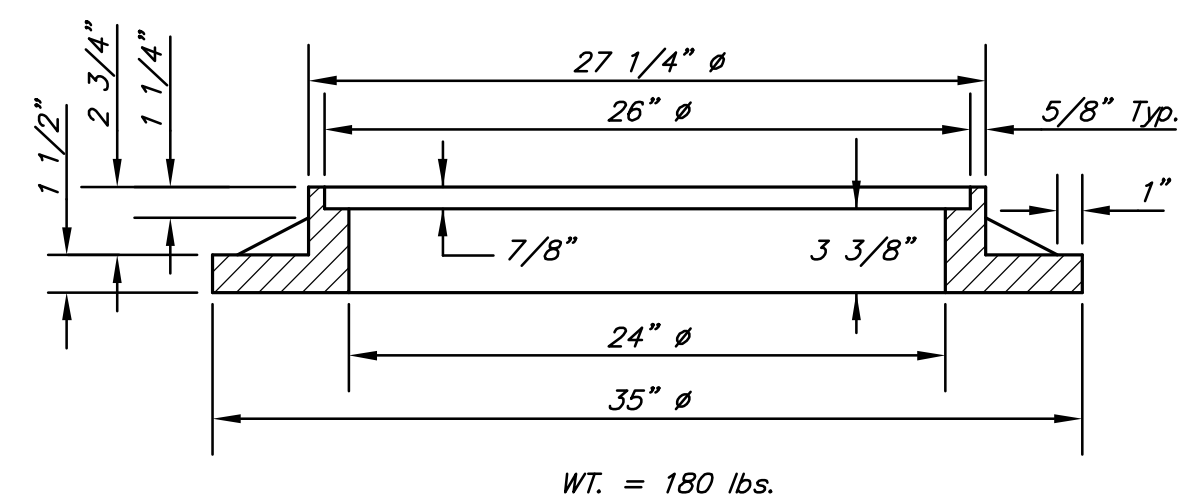
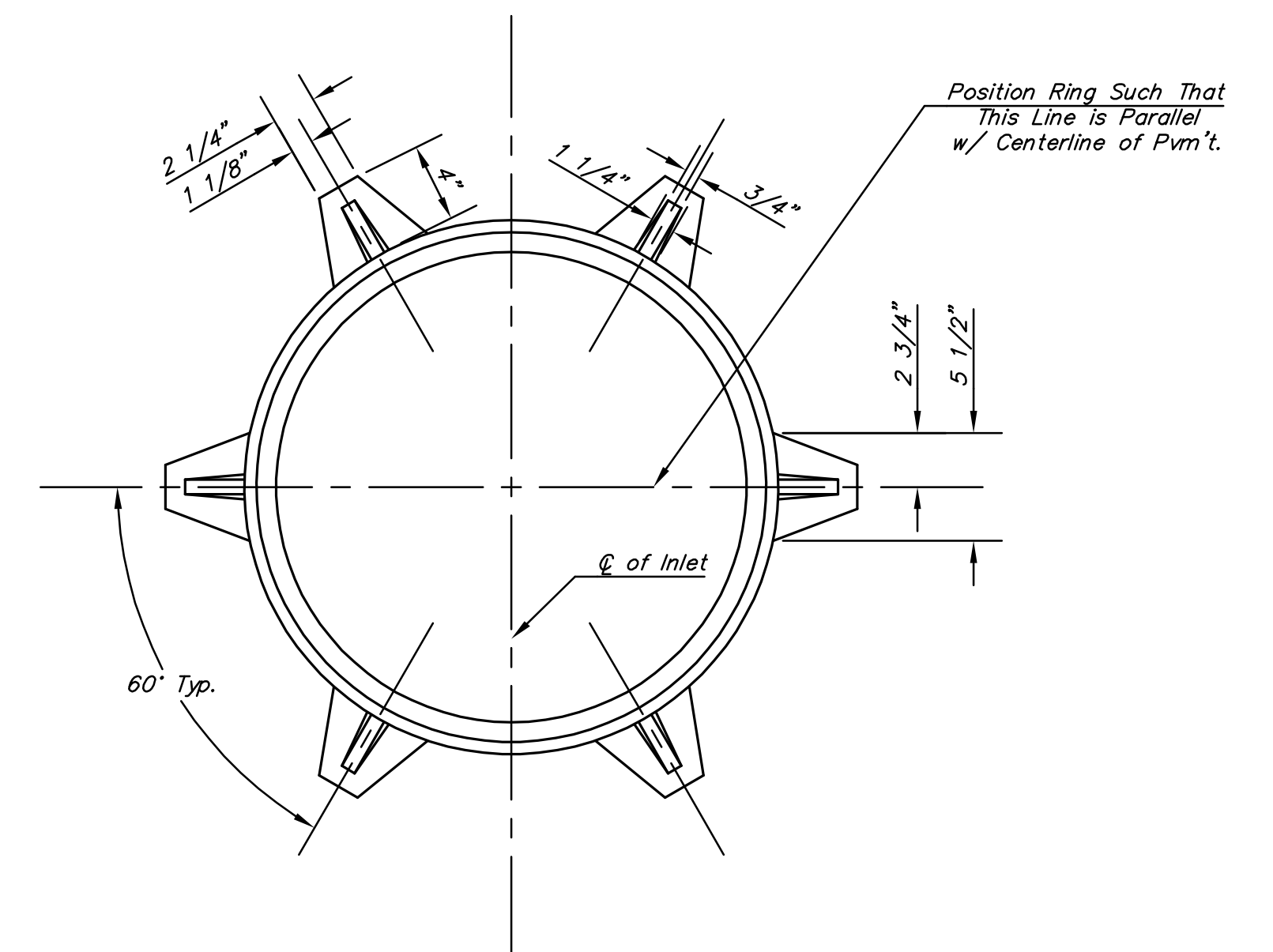

MANHOLE RING AND COVER

*See City of Wichita Standard Manhole Ring and Cover Detail Sheet for Cover Details to Be Used With Inlet Frame.

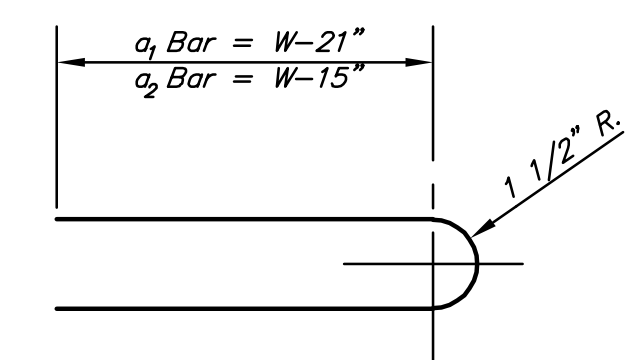

BENDING DIAGRAM

GENERAL NOTES

- Concrete tops to be installed on thin mortar cushion to insure full support along brick walls. Concrete tops may be cast in place or precast. Concrete used for inlet construction shall be concrete pavement mix.
- Contractor shall have the option of constructing 8" brick masonry walls between the concrete inlet base and top on this inlet when W=6'-4" and H=7'-0" or less.
- Inlet invert shall be shaped with 8 sack sand mix concrete to create flow channels and to increase hydraulic efficiency such that the inlet will be self cleaning between all inlet and/or outlet pipes.
- The ends of all pipes installed in inlets shall be cut off flush with the inside face of the inlet wall.

<p>THE CITY OF WICHITA CITY ENGINEER'S OFFICE CITY HALL - SEVENTH FLOOR 406 NORTH MAIN STREET WICHITA, KANSAS 67202 (316) 268-4501 (316) 268-4114 FAX</p>	<p>STANDARD TYPE 1 CURB INLET OPENING = 6" x 5'-0"</p>	
	<p>JIM ARMOUR, P.E. - CITY ENGINEER</p>	
	<p>PROJECT NUMBER 468-84546</p>	<p>INDEX CODE 751481</p>
	<p>DATE Nov 08</p>	<p>Sheet 2 of 12</p>