

EXPANSION JOINT

NOTE: Extra Thickness to be Subsidiary to Price of Square Yards Pavement

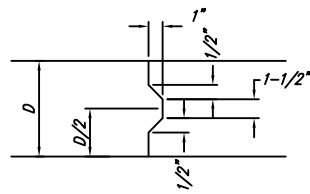

KEYWAY DETAIL

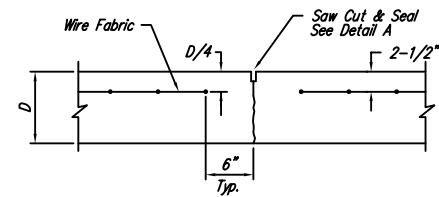

CONTRACTION JOINT DETAIL (C.J.)

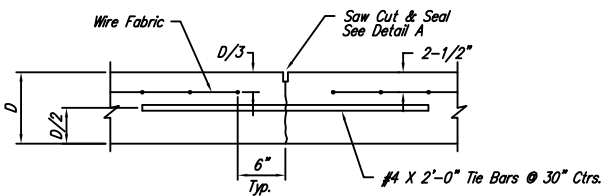

LONGITUDINAL JOINT DETAIL (L.J.)

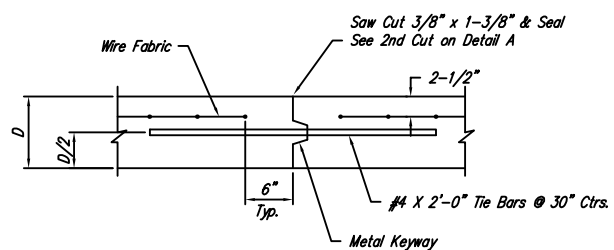

OPTIONAL LONGITUDINAL JOINT DETAIL (L.J.)

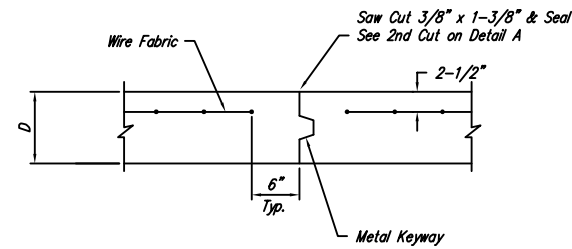

OPTIONAL CONTRACTION JOINT

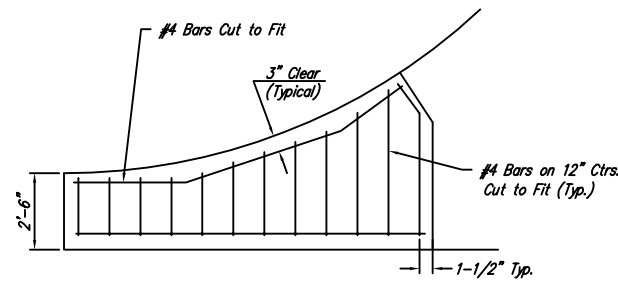

WING REINFORCING DETAIL

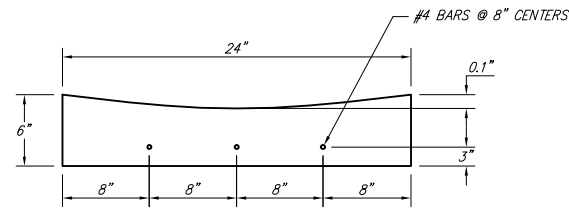

CONCRETE FLUME DETAIL

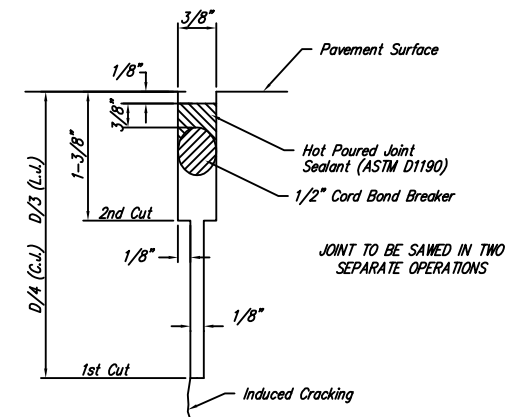

SAW JOINT DETAIL

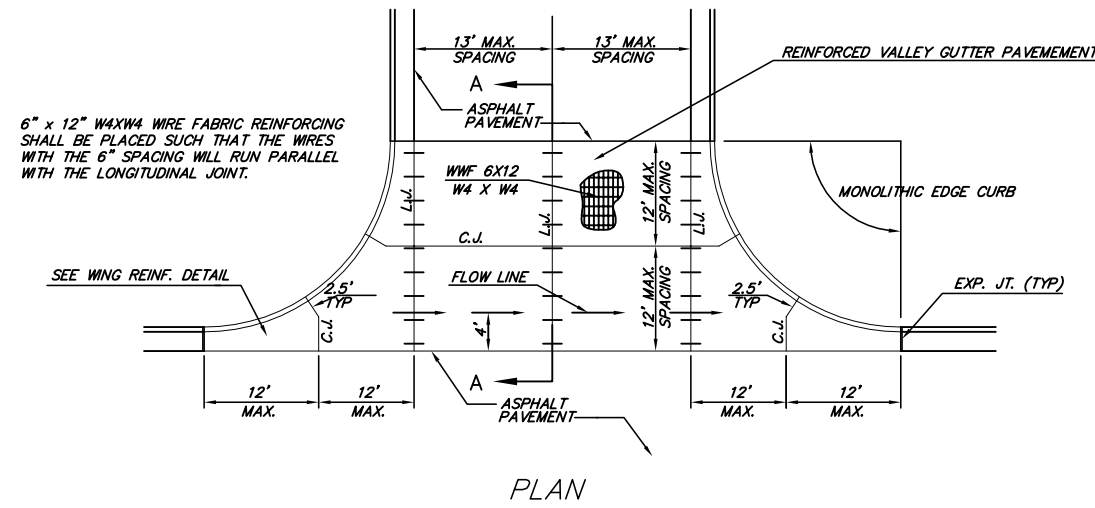

PLAN

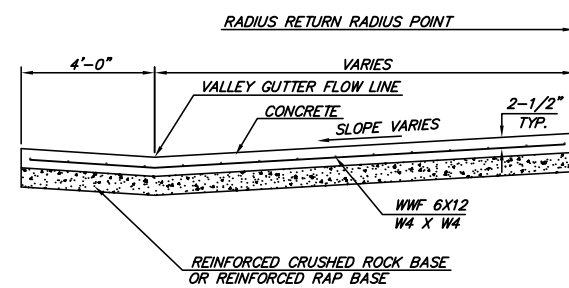

SECTION A-A

REINFORCED VALLEY GUTTER DETAIL

STANDARD WHEELCHAIR RAMP CONSTRUCTION DETAIL FOR CONCRETE STREETS WITH MONOLITHIC CURB (TYPE A)

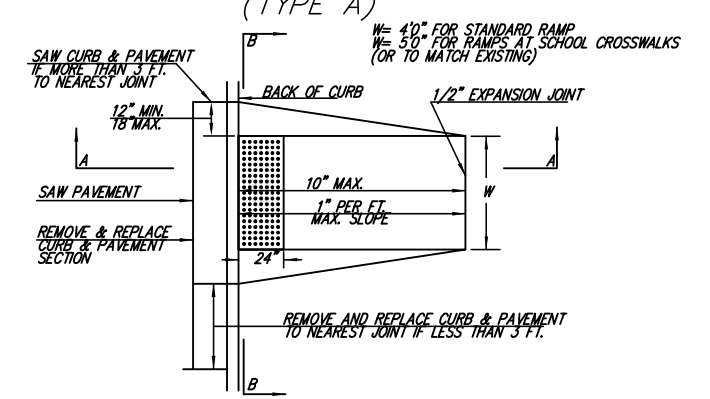

SECTION A-A

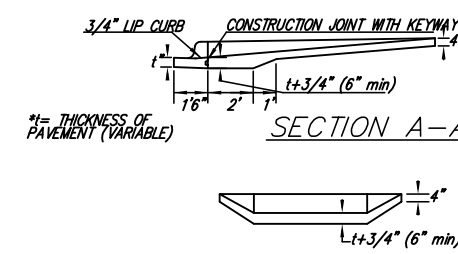

SECTION B-B

STANDARD WHEELCHAIR RAMP CONSTRUCTION DETAIL FOR STREETS WITH COMBINED CURB & GUTTER (TYPE A)

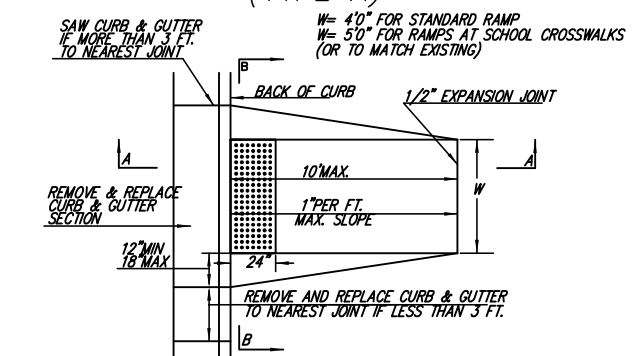

SECTION A-A

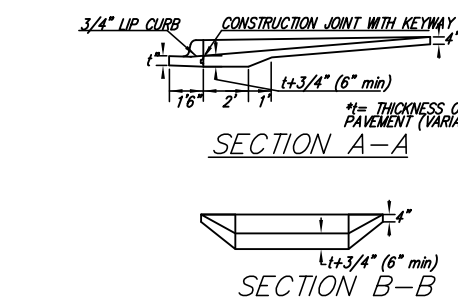

SECTION B-B

<p>THE CITY OF WICHITA</p>	<p>VALLEY GUTTER DETAILS</p>	
	<p>WHEELCHAIR RAMP DETAILS</p>	
<p>CITY ENGINEER'S OFFICE 435 NORTH MAIN STREET WICHITA, KANSAS 67202 (316) 268-4201 (316) 268-4114 FAX</p>	<p>PROJECT NUMBER 472-84426</p>	<p>OCA # 766113</p>
	<p>DATE MAR 96</p>	<p>SHEET 4 OF 33</p>