

**PAVEMENT UNDERDRAIN**

NOTE:  
Refer to "Pipe Connection Detail" on Sheet No. 55 for connections to structures.  
All Underdrain Pipe Shall Maintain a Minimal Slope of 0.5%

**CRUSHED ROCK UNDERDRAIN AGGREGATE GRADATION REQUIREMENTS**

Percent of Aggregate Retained	
1 1/2"	0
3/4"	15-60
# 4	40-80
#40	74-92
P-200	4-12

Rock quality shall be the same as specified for coarse aggregate for asphalt concrete mixes.

Note: Information on this sheet pertains to pavement underdrain only. See sht. 52 for PVC drain pipe details.

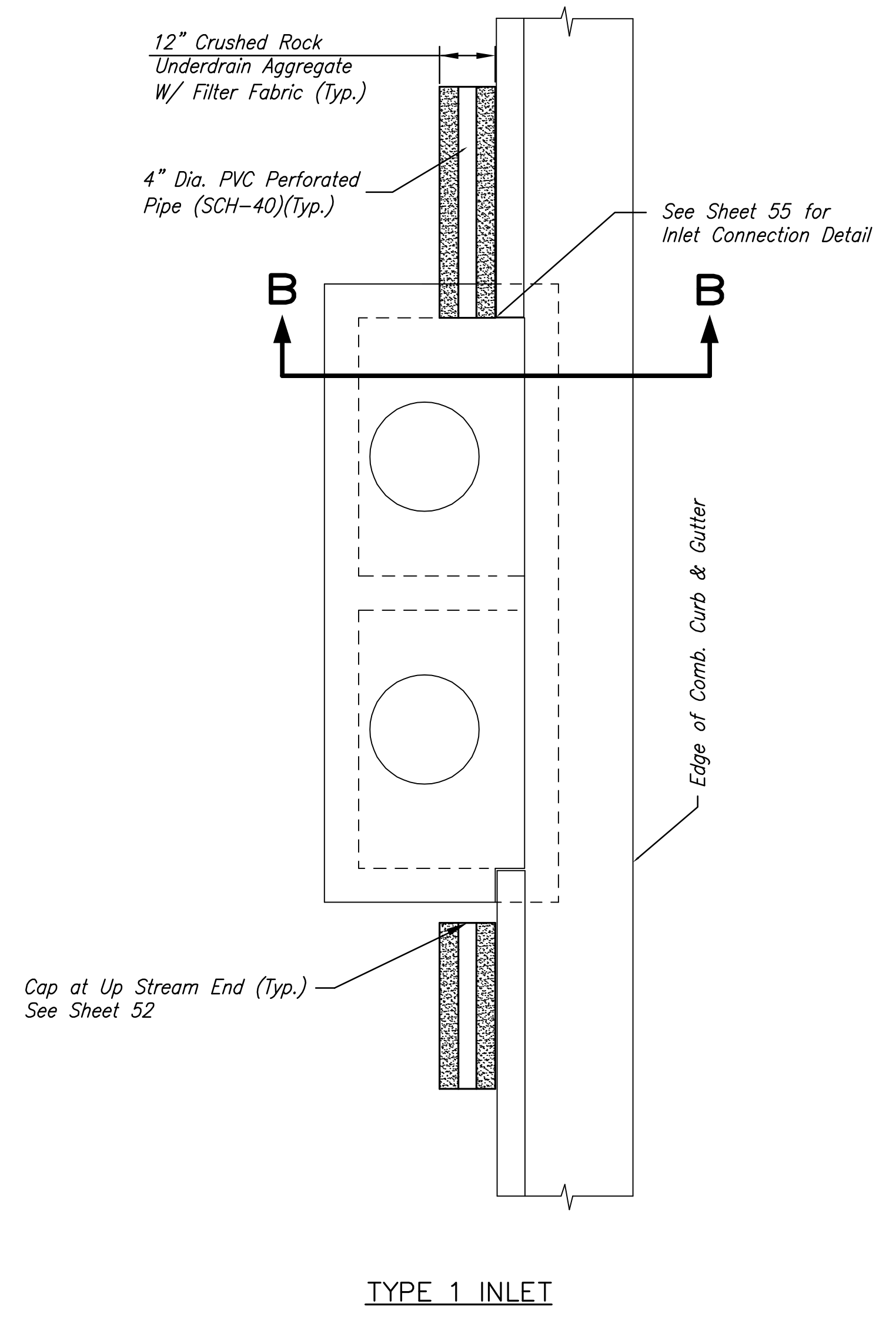
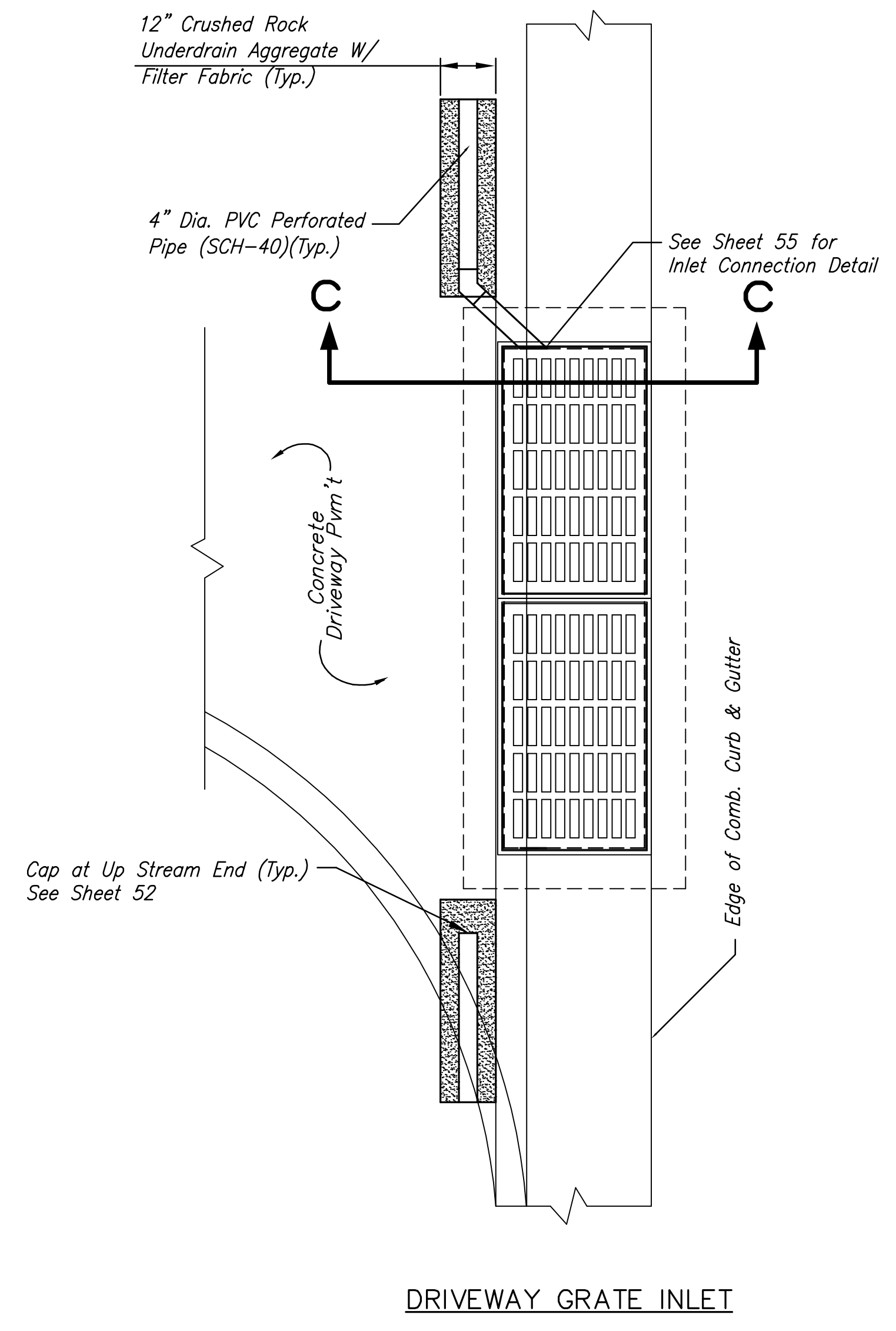

UNDERDRAIN SCHEDULE			
Side of 17th	Upstream Station	Downstream Station	Length
Lt.	50+50 Grove	49+48 17th	47
Rt.	49+50 Grove	49+48 17th	46
Lt.	50+50 Grove	50+51 17th	45
Rt.	49+50 Grove	50+51 17th	47
Lt.	52+70	50+61	209
Rt.	51+65	50+61	104
Lt.	54+20	52+87	133
Rt.	54+20	52+82	138
Lt.	57+05	54+82	223
Rt.	57+00	54+82	218
Lt.	60+40	57+22	318
Rt.	60+35	57+19	316
Lt.	63+15	60+52	263
Rt.	63+10	60+47	263
Lt.	70+20	63+78	642
Rt.	70+20	63+73	647
Lt.	75+70	70+33	537
Rt.	75+65	70+33	532
Lt.	50+55 Hillside	75+81 17th	47
Rt.	49+45 Hillside	75+29 17th	93
Lt.	50+55 Hillside	77+00 17th	44
Rt.	49+50 Hillside	76+98 17th	42
Lt.	81+30	77+10	420
Rt.	81+30	77+08	422
Side of Hillside			
Lt.	47+66 Hillside	49+27 Hillside	161
Rt.	47+50 Hillside	49+30 Hillside	180
Lt.	56+24 Hillside	50+70 Hillside	554
Rt.	54+70 Hillside	50+73 Hillside	397
		TOTAL	7,088

**17th STREET FROM GROVE TO HILLSIDE**

**PAVEMENT UNDERDRAIN DETAILS**

SHEET TITLE  
87 N-0349-01  
PROJECT NUMBER

DESIGN BY: JRA  
DRAWN BY: JSB  
CHECKED BY: JRA

ISSUED: May 28, 2009  
REVISED:

SHEET NO.  
51 of 133