

DEETER #2433 GRATE

24" x 24" Frame and Grate Detail

NOTE: Grates shall be imprinted on the top surface with "CITY OF WICHITA" using letters at least 1" in height. Other marking methods may be approved by the engineer.

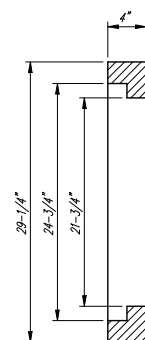
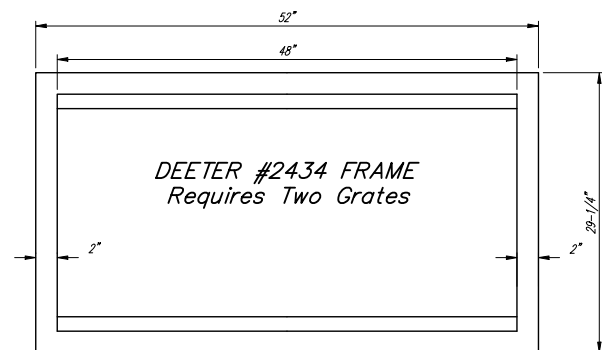

DEETER #2434 FRAME
Requires Two Grates

Double 24" x 24" Frame Detail

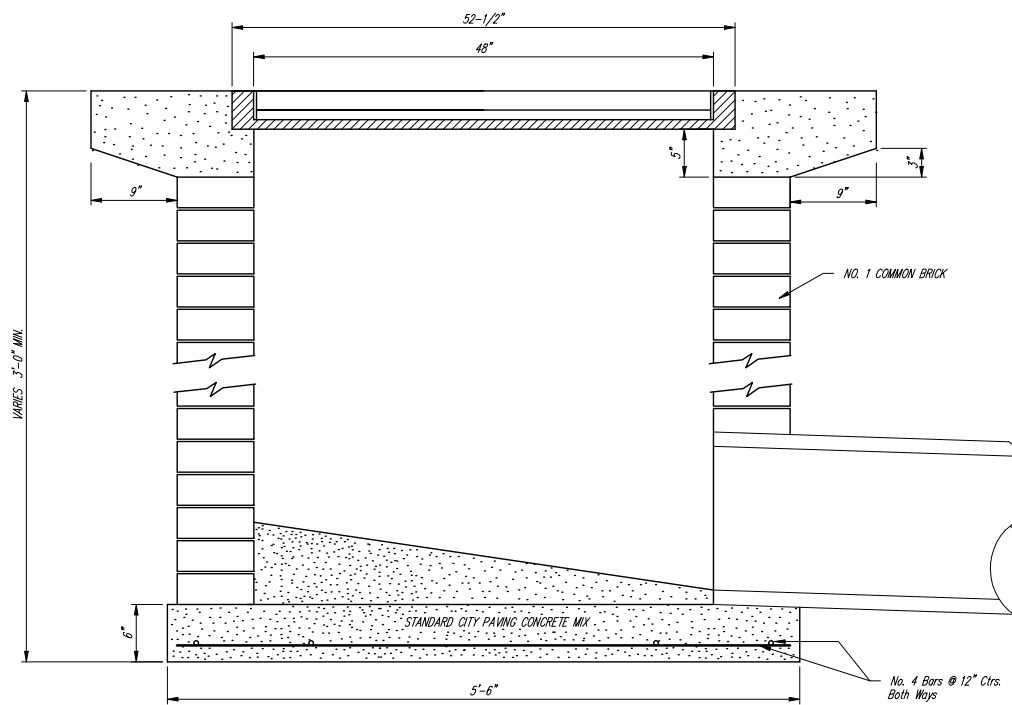
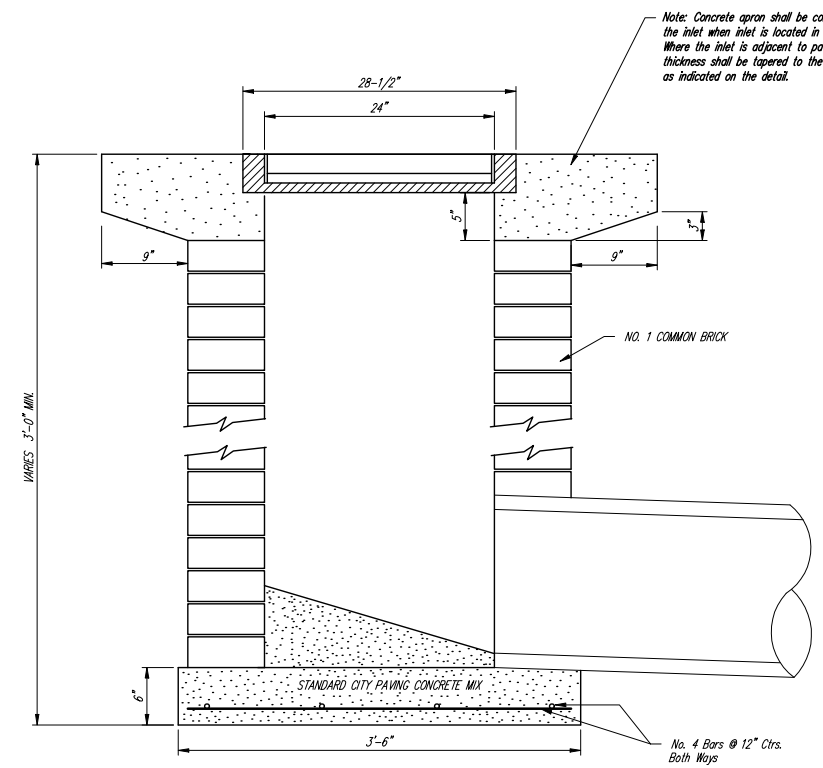
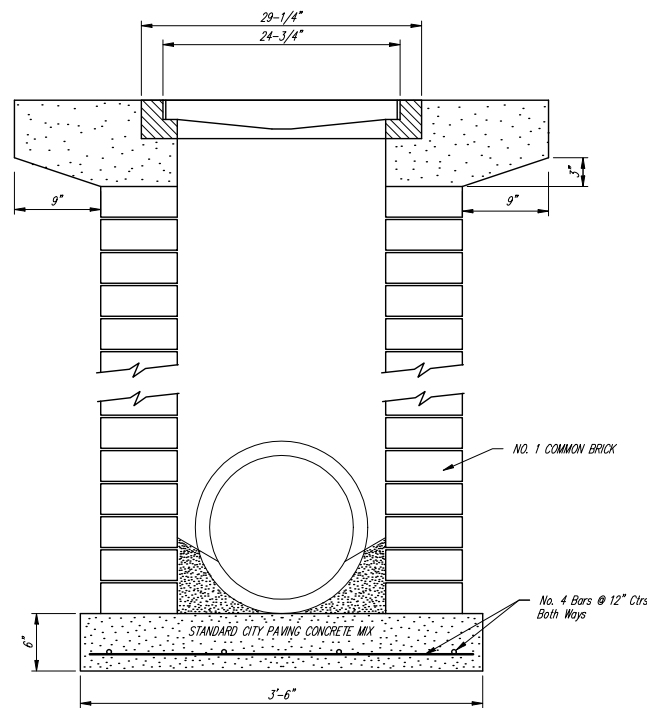

Baughman		City of Wichita Standard	
		Drop Inlet Detail	
Baughman Company, P.A. 315 8th St. Wichita, KS 67211 P 316-262-7271 F 316-262-0149			
ENGINEERING SURVEYING PLANNING LANDSCAPE ARCHITECTURE			
PROJECT NUMBER 472-64291	DESIGN C.O.W.	DRAWN STAFF	
REVISIONS	APPROVED	DATE 06/06	
	SCALE NONE		
	SHEET	35 OF 61	
\DropIn2		06-02-E502	