

GENERAL NOTES

- CONCRETE DRIVEWAY CONSTRUCTION DETAILED ON THIS SHEET IS FOR USE WITH FULL HEIGHT STREET CURBS.
- ONE LONGITUDINAL JOINT SHALL BE CONSTRUCTED ALONG THE CENTERLINE OF CONCRETE DRIVES HAVING A "W" DIMENSION OF 7.310m OR LESS. TWO LONGITUDINAL JOINTS SHALL BE CONSTRUCTED WITH EQUAL SPACINGS NOT TO EXCEED 3.050m FOR CONCRETE DRIVES WITH A "W" DIMENSION GREATER THAN 7.310m.
- JOINT SPACING IN THE DRIVEWAY WALK SECTION SHALL BE A MINIMUM OF 910mm AND A MAXIMUM OF 1830mm AND ARE TO BE EQUALLY SPACED WITHIN THIS RANGE. WALK SECTION SHALL BE CONSTRUCTED TO THE SAME THICKNESS AS THE DRIVEWAY.
- DOWEL BARS SHALL BE OMITTED FROM THE KEYED CONSTRUCTION JOINT ALONG THE BACK OF THE STREET CURB LINE WHEN DRIVEWAYS ARE CONSTRUCTED IN CONJUNCTION WITH NEW CONCRETE PAVEMENT CONSTRUCTION.
- ADDITIONAL THICKNESS OF DRIVE AS INDICATED IN THE DRAWINGS WILL NOT BE PAID FOR DIRECTLY AND THIS COST SHALL BE INCLUDED IN THE UNIT PRICE BID FOR THE DRIVEWAY CONSTRUCTION.
- 13mm (1/2") EXPANSION JOINTS SHALL ALSO BE INSTALLED ALONG THE PROPERTY LINE AND/OR BACK OF WALK LINE WHEN DRIVE CONSTRUCTION ALONG THIS LINE ABUTS CONCRETE PARKING LOTS OR CONCRETE DRIVE EXTENSION.
- ALL CONCRETE RESIDENTIAL DRIVEWAYS SHALL BE A MINIMUM OF 150mm IN THICKNESS AND SHALL BE WITH REINFORCEMENT. DRIVEWAYS MAY BE CONSTRUCTED THICKER THAN 150mm WITH 150mmX300mm W4-W4 WELDED WIRE FABRIC WHEN PROPERLY AUTHORIZED BY THE PROPERTY OWNER WITH THE ENGINEERS CONCURRENCE. NO EXTRA PAYMENT WILL BE MADE FOR DRIVEWAYS THICKER THAN 150mm.
- ALL CONCRETE COMMERCIAL DRIVEWAYS SHALL BE A MINIMUM OF 200mm IN THICKNESS AND SHALL BE WITH REINFORCEMENT. DRIVEWAYS MAY BE CONSTRUCTED THICKER THAN 200mm WITH 150mmX300mm W4-W4 WELDED WIRE FABRIC WHEN PROPERLY AUTHORIZED BY THE PROPERTY OWNER WITH THE ENGINEERS CONCURRENCE. NO EXTRA PAYMENT WILL BE MADE FOR DRIVEWAYS THICKER THAN 200mm.
- COMPACTION OF SUBGRADE BENEATH PROPOSED DRIVES SHALL NOT BE PAID FOR DIRECTLY, BUT SHALL BE INCLUDED IN THE UNIT PRICE FOR THE BID ITEM REIN. CONC. DRIVE PVMT.

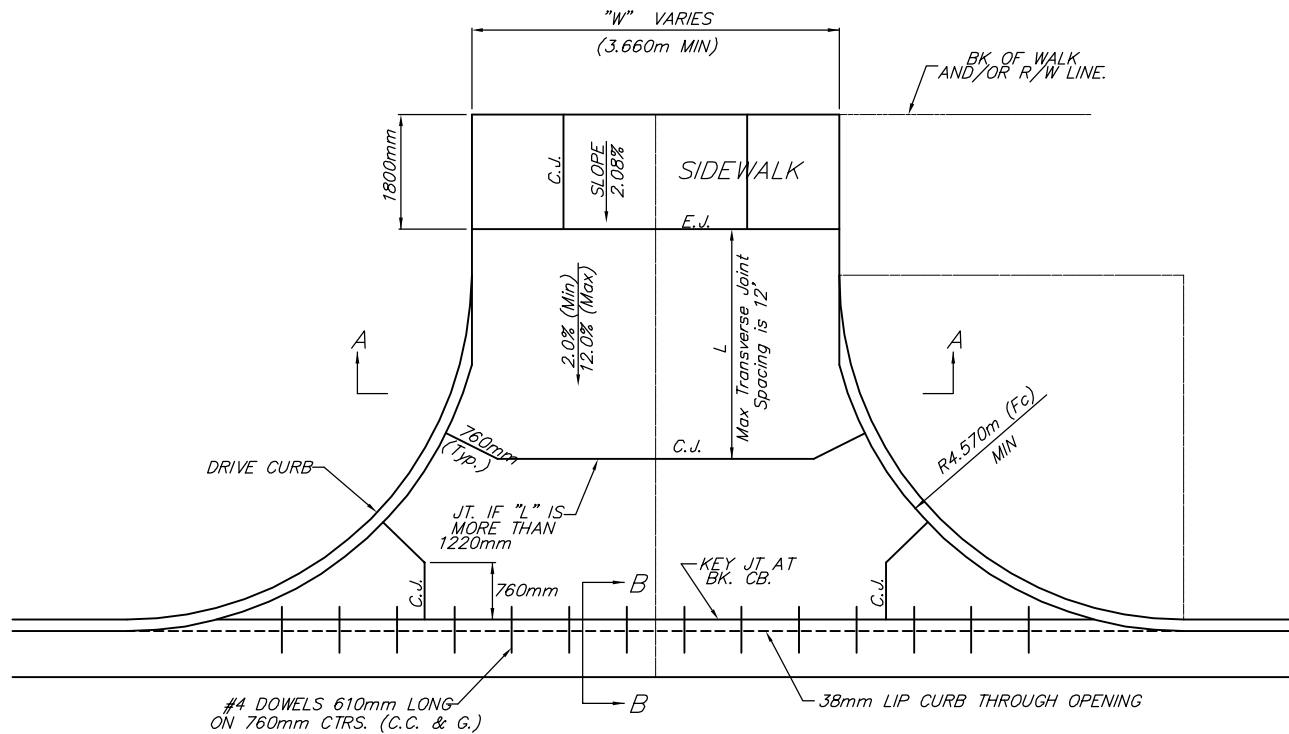

CONCRETE FULL RADIUS DRIVES
(RESIDENTIAL DRIVES)

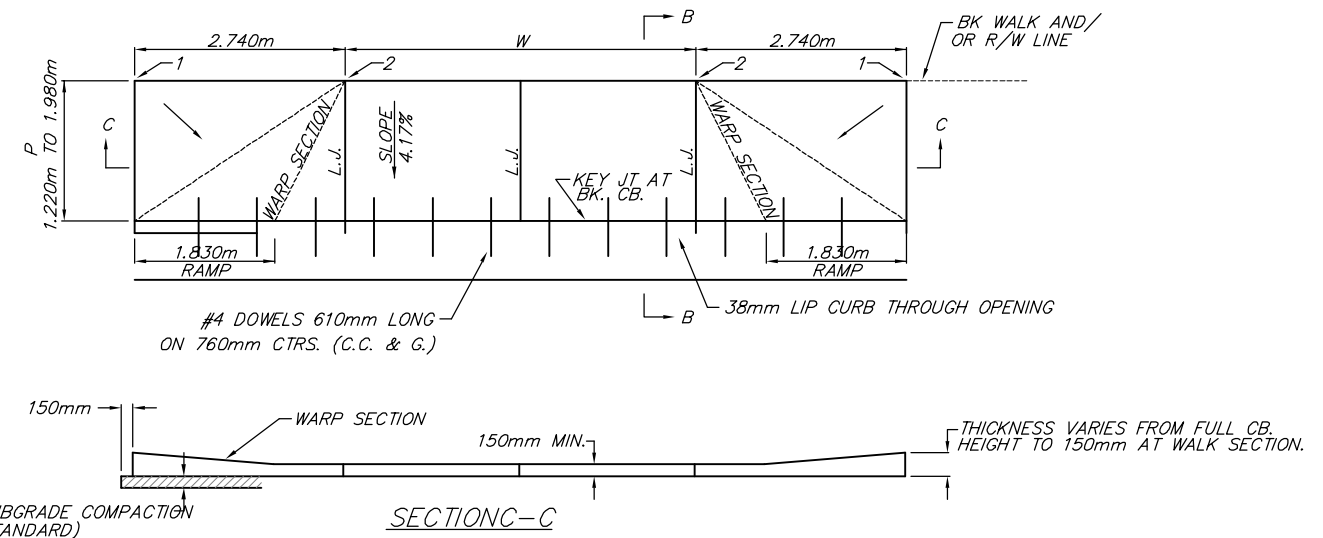
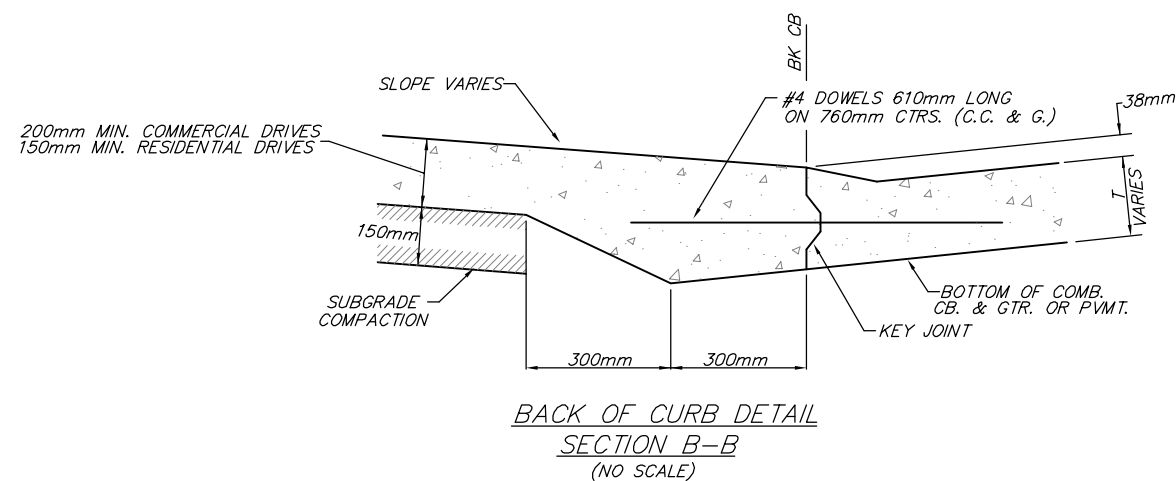
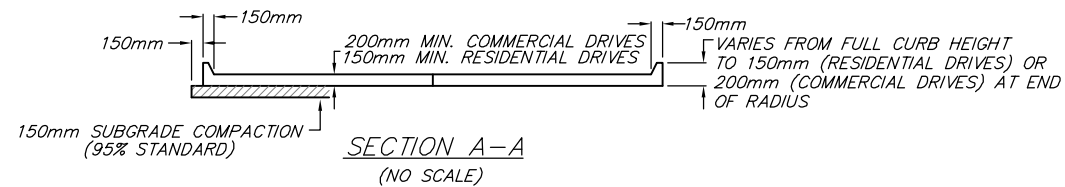

PARKING WIDTH "P"	1.220m	1.370m	1.520m	1.680m	1.830m	1.980m
DIST. OF PT "1" ABOVE TOP OF FULL CURB	24mm	27mm	30mm	37mm	40mm	43mm
DIST. OF PT "2" BELOW TOP OF FULL CURB	-79mm	-73mm	-67mm	-61mm	-55mm	-49mm

FULL RAMP DRIVE (P = 1.220m TO 1.980m)



PROJECT NUMBER 472-83863		SHEET NAME Std Drive		ENGINEERING DIRECTORY F:\29th North\Details	
DESIGN	DRAWN	APPROVED	DATE	SCALE	BAUGHMAN NO
	STAFF	JFB	Oct. 2004	None	02-02-E232

STANDARD DRIVE DETAIL

BAUGHMAN COMPANY, P.A.
ENGINEERING, SURVEYING, & PLANNING
316-262-7271 • 315 ELLIS • WICHITA, KANSAS 67211