

FHWA REGION NO.	STATE	PROJECT NO.	FISCAL YEAR	SHEET NO.	TOTAL SHEETS
7	KANSAS	87 N-0294-01	2004	55	129

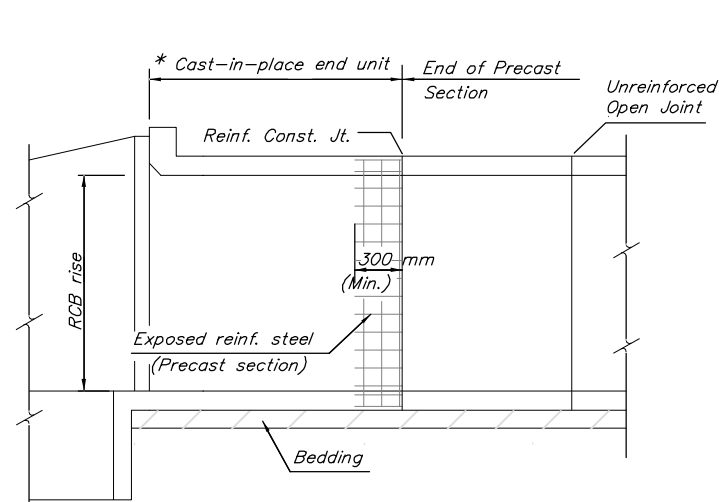

ELEVATION AT HEADWALL

* Minimum barrel length of cast-in-place end unit shall equal the RCB rise or 2 400 mm, whichever is less. This length can be used when the joint between the cast-in-place end unit and the precast section is reinforced as shown.

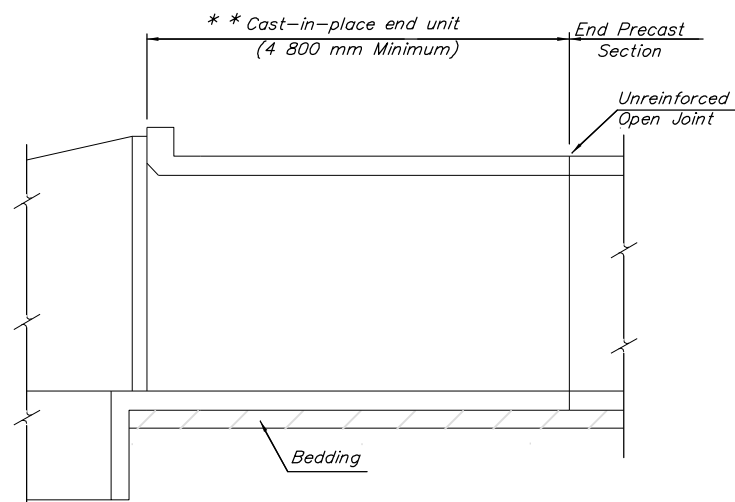

ELEVATION AT HEADWALL

** Minimum barrel length of cast-in-place end unit shall be 4 800 mm when using an unreinforced open joint at the end of the precast section.

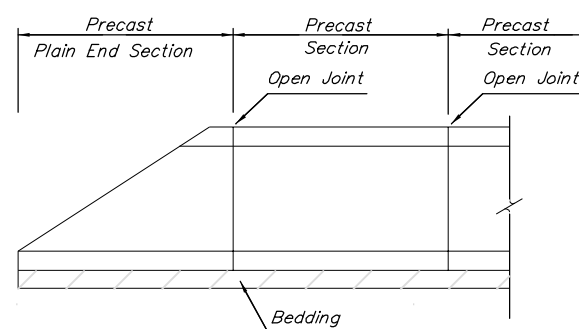

ELEVATION AT PRECAST END SECTION

(Precast End Sections are permitted where straight wings are shown in the plans or at the downstream end for single cell RCB with a rise of 1 830 mm or less.)

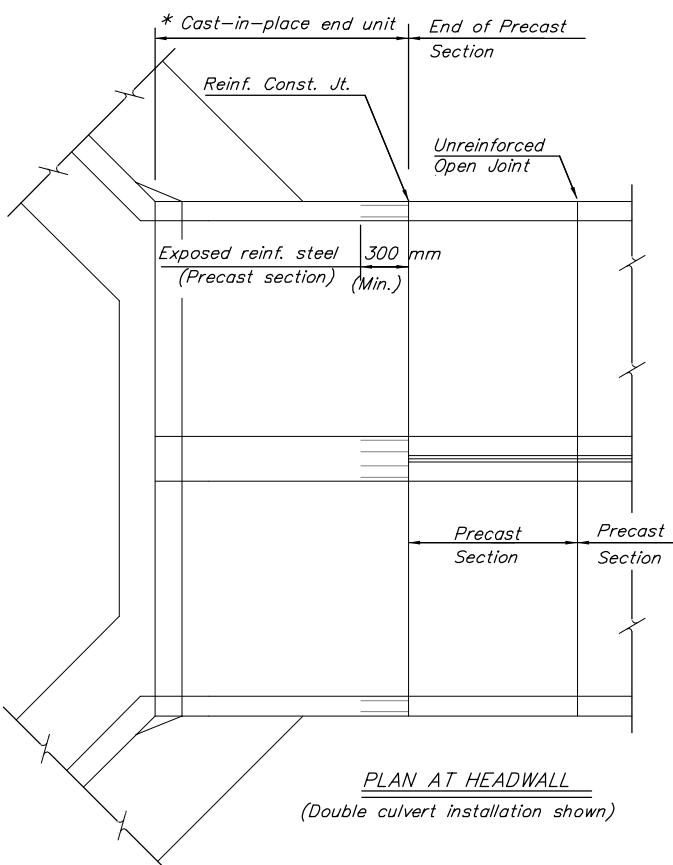

PLAN AT HEADWALL
(Double culvert installation shown)

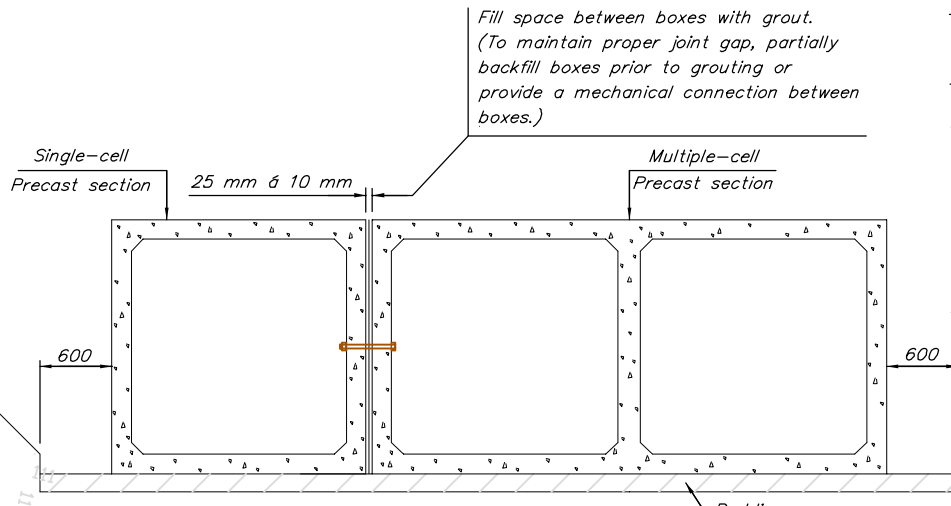

TYPICAL INSTALLATION DETAILS
(Example Only)

NOTE: See "Bridge Excavation" sheet, (Std. No. BR100 SI), for excavation details and basis of payment.

NOTE: Minimum length of precast section shall be 1 200 mm.

NOTE: A single cell box of equivalent area may be substituted for a double cell box with cell spans less than or equal to 1 830 mm. Any revision in the cell height from that shown on the plans will not be permitted, unless approved by the Engineer. Two single cell boxes may be substituted for a double cell box, when approved by the Engineer.

NOTE: See respective RCB Standard Sheets for cast-in-place details.

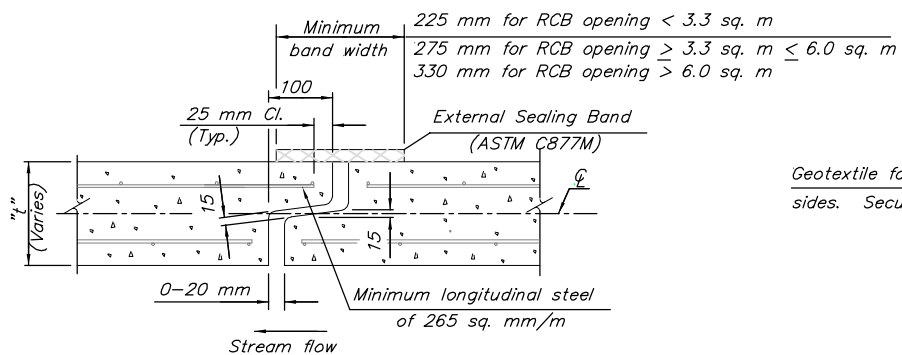

OPTION "B"

OPEN JOINT DETAIL

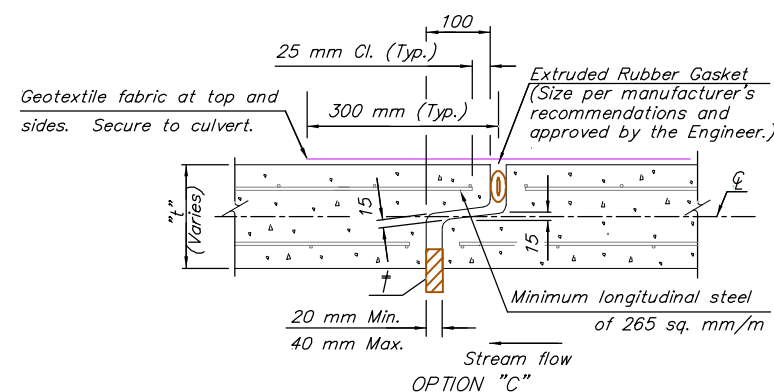

† Insert temporary, 20 mm-25 mm wide, hardwood wedges to prevent over-compressing gasket.

GENERAL NOTES

PRECAST BOX CULVERTS: If precast boxes are specified, construct them at the locations shown in the plans and according to the requirement shown on this sheet. When approved by the Engineer, precast box culverts may be used in lieu of cast-in-place box culverts. If the Contractor chooses the precast option, use the cast-in-place quantities as the cost basis. This cost includes all labor equipment, material and incidentals necessary to complete the installation.

Unless otherwise approved by the Engineer, use cast-in-place collars at horizontal and vertical changes in RCB alignment. Use cast-in-place end sections and wingwalls except as noted on this sheet. The Engineer may require cast-in-place sections at junctions of drainage structures.

Cast-in-place concrete work shall conform to the requirements of the KDOT Specifications and KDOT's "Guidelines for Structural Design and Detail of Reinforced Concrete Box Culverts". Use Grade 28 concrete and Grade 420 reinforcing steel conforming to ASTM A615M for cast-in-place construction.

SPECIFICATIONS: Single-cell Precast Concrete Box Culverts shall conform to the requirements of the following specifications except as noted in the KDOT Specifications. Design multiple-cell precast boxes in accordance with the criteria used to develop the single-cell precast boxes. (See Appendix of ASTM Specification C 1433M, Table 2 and the latest AASHTO Specifications.)

DISTRIBUTION SLAB: Fill heights less than 600 mm require a distribution slab. Construct the distribution slab over the width of the exterior walls of the barrel to the outside edges of the roadway shoulders. Terminate the slab a minimum of 600 mm from the edge of a barrel segment.

A cast-in-place distribution slab shall be a minimum of 150 mm thick, reinforced with #13 bars at 450 mm transversely and #16 bars at 300 mm along the barrel. Substitution of an equivalent welded wire fabric is acceptable.

Precast distribution slabs with the same thickness and reinforcement as a cast-in-place slab may be used when fill heights exceed 300 mm. Center the joints of the precast distribution slabs over the barrel segments. Provide a minimum of 75 mm of granular material between the barrel and the precast distribution slab.

Options:

a) Reinforced concrete pavement (min. 150 mm thick) will meet the requirements of a distribution slab. Reinforce as noted above. Provide a minimum of 75 mm of granular material between the concrete pavement and the precast boxes.

b) Asphalt pavement (min. 150 mm thick) will meet the requirements of a distribution slab. Provide a minimum of 150 mm of granular material between the asphalt and the precast boxes. Also provide a geogrid on top of the granular material.

A special design will be required when the above options are not geometrically possible.

NO.	DATE	REVISIONS	BY	APP'D
4	03-19-02	Concrete from Class to Grade	RAM	KFH
3	07-31-01	Revised Notes	RAM	KFH
2	11-03-00	Revised ASTM / Added Note	RAM	KFH
1	12-20-96	Revise CIP end unit details.	RAM	KFH

KANSAS DEPARTMENT OF TRANSPORTATION

PRECAST CONCRETE BOX CULVERT DETAILS

BR031 SI

FHWA APPROVAL	03-19-02 APP'D	KENNETH F. HURS
DESIGNED	DETAILED	JKI QUANTITIES
DESIGN CK.	DETAIL CK.	LRR QUANCK.
		TRACE CK.