

NOTE:  
Expansion Joint Only in Curb Area with Concrete Pavement.

**PLAN**

\*Left Side Shown Without Slab Reinforcing, Right Side Shown With Slab Reinforcing

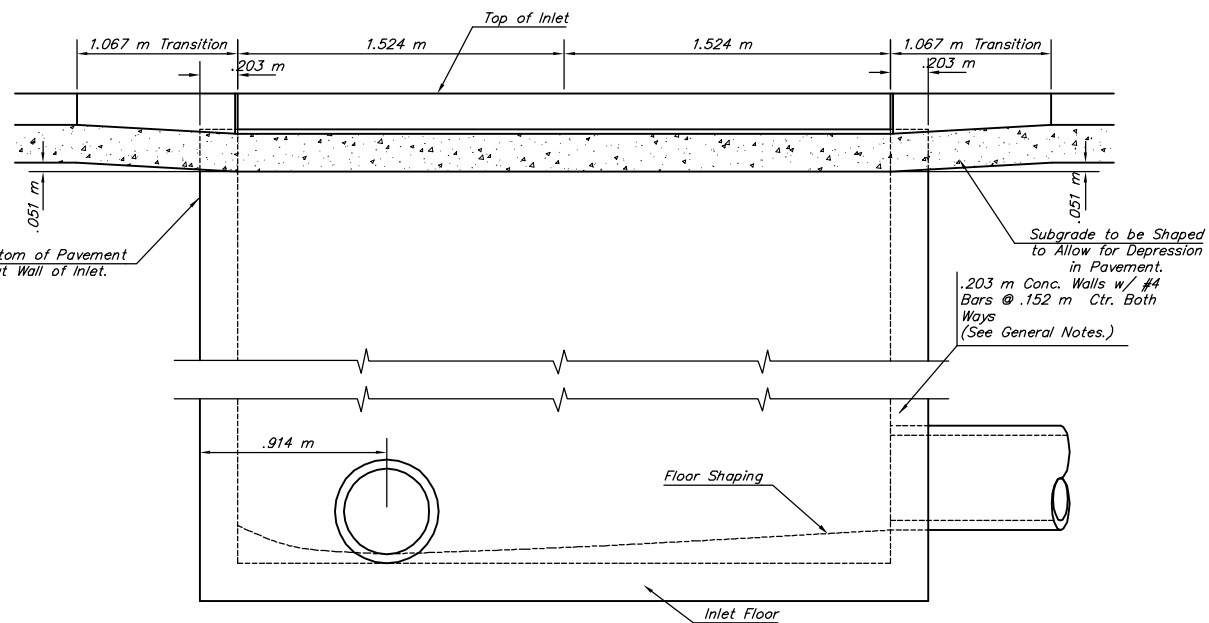

**ELEVATION**

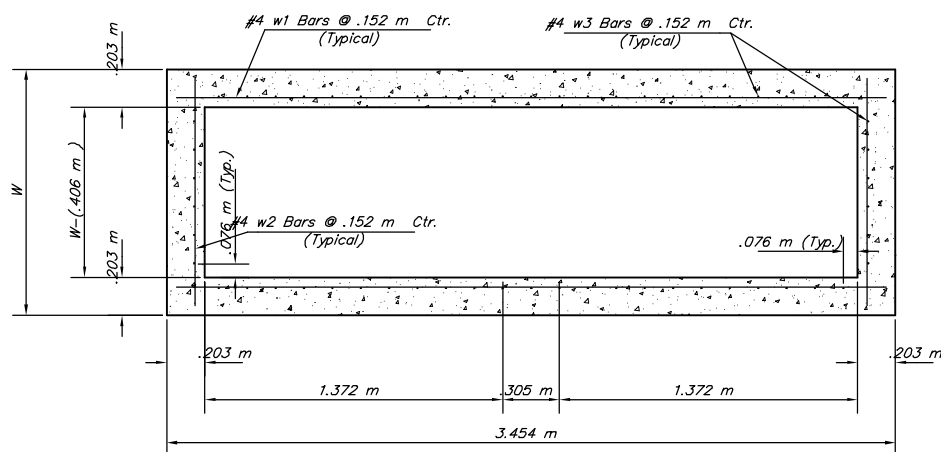

**SECTION B-B**

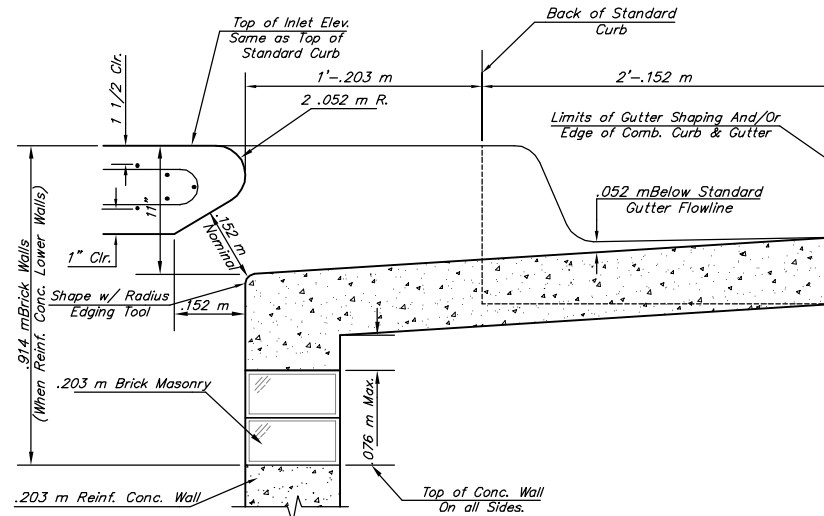

**SECTION C-C**

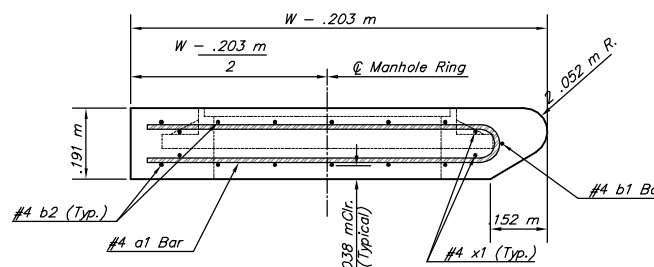

**SECTION A-A**

PRECAST SLAB AND FLOOR REINFORCING											
		W = 1.321 m		W = 1.626 m		W = 1.930 m		W = 2.235 m		W = 2.540 m	
MARK	SIZE	NO.	LENGTH	NO.	LENGTH	NO.	LENGTH	NO.	LENGTH	NO.	LENGTH
* a1	#4	13	2.006 m	13	2.616 m	13	3.226 m	13	3.835 m	13	4.445 m
a2	#4	4	1.829 m	4	2.048 m	4	3.048 m	4	3.658 m	4	11.219 m
a3	#4	23	1.244 m	23	1.544 m	23	1.854 m	23	2.159 m	23	2.464 m
b1	#4	1	2.972 m	1	2.972 m	1	2.972 m	1	2.972 m	1	2.972 m
* b2	#4	23	3.378 m	29	3.378 m	35	3.378 m	41	3.378 m	47	3.378 m
x1	#4	16	1.168 m	16	1.270 m	16	1.372 m	16	1.473 m	16	1.574 m

WALL REINFORCING											
		W = 1.321 m		W = 1.626 m		W = 1.930 m		W = 2.235 m		W = 2.540 m	
MARK	SIZE	NO.	LENGTH	NO.	LENGTH	NO.	LENGTH	NO.	LENGTH	NO.	LENGTH
w1	#4	①	3.378 m	①	3.378 m	①	3.378 m	①	3.378 m	①	3.378 m
w2	#4	①	1.244 m	①	1.544 m	①	1.854 m	①	2.159 m	①	2.464 m
w3	#4	52	②	56	②	60	②	64	②	68	②

\* Field Bend or Cut Reinforcing as Required for Clearance.  
① 4 (H1 - .305 m) (H1 - .533 m) Rounded down to nearest 0.5'  
② H1 - .076 m

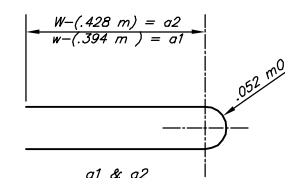

**BENDING DIAGM**

STANDARD CURB INLET PRECAST TOPS				
W	PRE-CAST TOP SIZE	PIPE SIZE	CU. YD. CONC.	
1.321 m	1.118 m 3.454 m .191 m	.533 m & SMALLER	0.83±	
1.626 m	1.623 m 3.454 m .191 m	.610 m & .762m	1.09±	
1.930 m	1.727 m 3.454 m .191 m	.914 m & 1.067 m	1.35±	
2.235 m	2.032 m 3.454 m .191 m	1.219 m & 1.372 m	1.61±	
2.540 m	2.337m 3.454m .191 m	1.524 m & 1.676 m	1.87±	

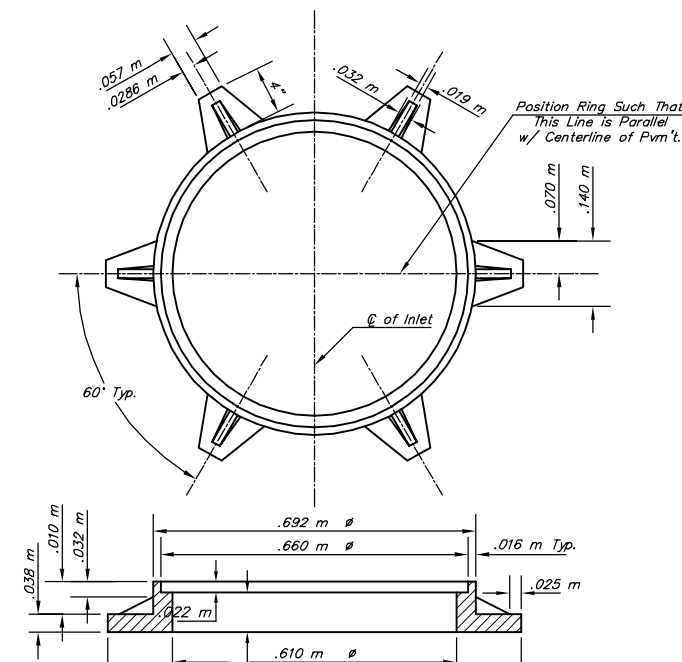

**MANHOLE RING AND COVER**

Weight = 180 lbs.

\*See City of Wichita Standard Manhole Ring and Cover Detail Sheet for Cover Details to Be Used With Inlet Frame.



Revised - Feb. 16, 1989