

**NOTES:**

Curb cut ramps are to be located as shown on the plans or as directed by the Engineer.

The normal gutter line profile shall be maintained through the area of the ramp. If possible, drainage structures should not be placed in line with ramps. Except where existing drainage structures are being utilized in the new construction, location of the ramp should take precedence over location of drainage structure.

Sidewalks shall be ramped where the driveway curb is extended across the walk. Care shall be taken to assure a uniform grade on the ramp, free of sags and short grade changes.

Expansion joints shall be placed in sidewalks as follows: In long runs, expansion joints shall be 3/4" redwood boards flush with the surface, at a maximum spacing of 125'. This same joint should be used at sidewalk junctions as shown in Typical Plan.

Where the end of the sidewalk abuts a curb, a 3/4" redwood board flush with the surface shall be used.

Where the sidewalk is parallel and adjacent to a rigid structure, a 1/2" pre-moulded joint filler (Non-extruding, Type B) shall be used.

Sidewalk shall slope toward the street at a maximum of 1:50, and where necessary, may be de-pressed or sloped to fit alleys and entrances as shown on the plans or as directed by the Engineer.

Where clear width of sidewalk between top of ramp and building or other obstruction is less than 48 inches, the slope of the flared sides shall not exceed 1:12.

Where sidewalk is shown to be constructed back of an entrance it shall be 6" thick with welded wire mesh reinforcement of the same gauge and spacing of wires as in entrance pavement, as shown in the Reinforcement Diagram. Bid item will be "Sidewalk Construction (6") either with or without air entrainment.

Where the plans do not require air entrainment for sidewalk and sidewalk ramps, at the Contractor's option, Class A Concrete (AE) may be used throughout. Payment will be made as square yards of Sidewalk Construction.

At the Contractor's option Class A Concrete (AE) may be used throughout for construction of steps, but payment will be made as Class A Concrete.

Surface texture of the ramp shall be that obtained by a coarse brooming or steel tining transverse to the slope of the ramp and shall be sufficient to provide a ramp surface which contrasts with adjacent surfaces.

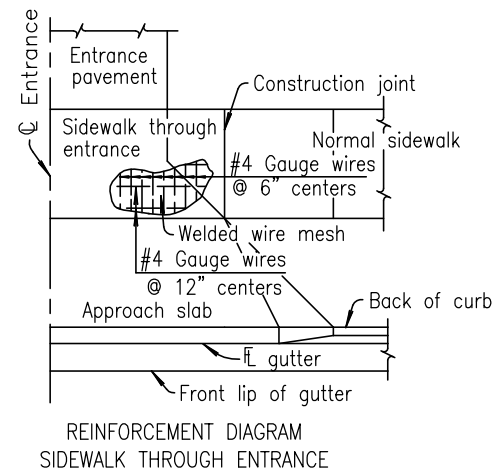

**NOTE:**

Sidewalk shall always have a cross-slope of 1/4 inch per foot or less, even through driveways unless directed otherwise by the Engineer.

Variable width (5'-0" min.). Entrance walk to be same width as approach walk. Sidewalk width of 4'-0" may be used where existing conditions prohibit use of 5'-0".

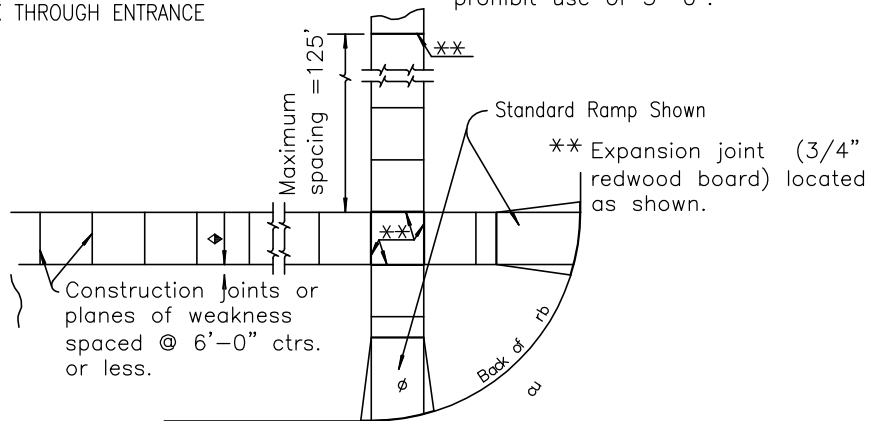

TYPICAL PLAN SIDEWALK

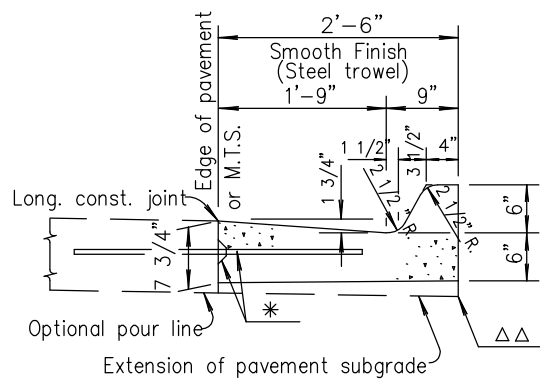

TYPICAL SECTION

COMBINED CURB & GUTTER - TYPE I (2'-6" WIDTH)

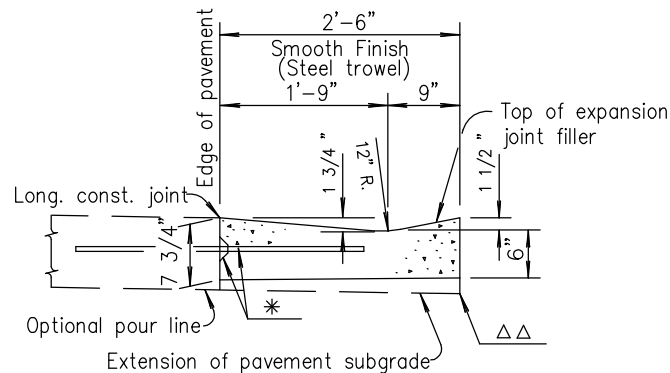

TYPICAL SECTION

COMBINED CURB & GUTTER - TYPE II (2'-6" WIDTH)

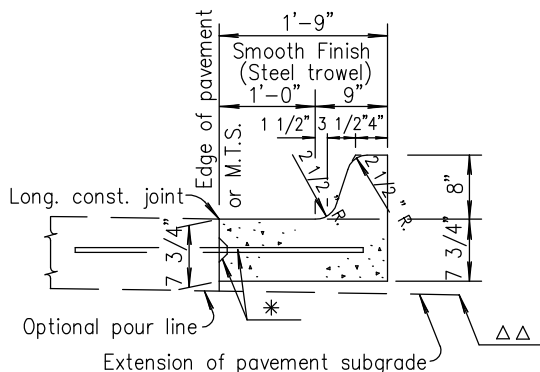

TYPICAL SECTION

COMBINED CURB & GUTTER - TYPE III (1'-9" WIDTH)

\* Longitudinal construction joint and #4 x 3'-0" bars @ 2'-6" ctrs., where concrete pavement is constructed.

ΔΔ Contractor has the option of thickening the curb and gutter as shown.

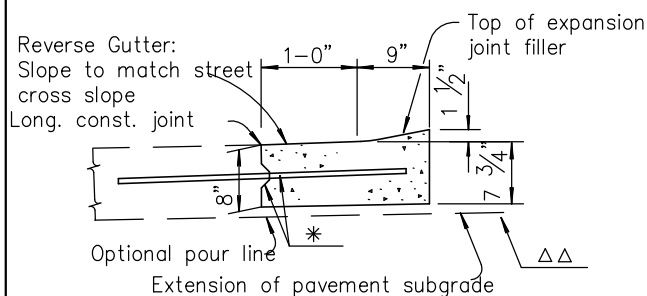

TYPICAL SECTION

COMBINED CURB & GUTTER - TYPE III (1'-9" WIDTH) MODIFIED HEIGHT

STATE	PROJECT NO.	YEAR	SHEET NO.	TOTAL SHEETS
KANSAS	87 N-0307-01	2006	30	89

**GENERAL NOTE**

Combined curb and gutter or gutter adjoining concrete pavement may, at the contractor's option, be poured either monolithically or separately, using either the mix used in the concrete pavement or Class "A" Concrete (AE). The combined curb and gutter or gutter shall have the same section as shown on the plans. If poured monolithically, dowel bars may be omitted from the combined curb and gutter or gutter, but the wire mesh shall be extended to 6" or less from the back of the curb or gutter. Pavement joints shall be continued through curb or gutter and no other planes of weakness will be required. Joints in the combined curb and gutter or gutter are to be filled with the same material as used for the pavement joints.

Expansion joints in the combined curb and gutter are to be placed opposite expansion joints in the pavement.

Where combined curb and gutter or gutter does not abut concrete pavement or concrete base course, omit tie bars and longitudinal construction joint and place a 1" pre-moulded Expansion Joint Filler (Nonextruding, Type B) cut to the dimensions of the combined curb and gutter or gutter, at a spacing of not to exceed 250' and at the ends of curb returns.

Where combined curb and gutter or gutter is adjacent to bituminous construction, planes of weakness shall be constructed at 20'-0" intervals.

A 4' length of transition from normal gutter section to the tapered gutter section shall be used at the ends of each run of gutter except where the gutter abuts a curb, such as at the end of a bridge. Inlets shall be located so as not to fall within this transition section.

Where pressure relief joint (Urethane Foam) is placed across the pavement, and gutter or curb and gutter is continued on for more than 10', use Type B, nonextruding, joint filler through gutter section, shaped to fit gutter or curb and gutter. Material may be solid Type B, approximately 4" thick, or other thickness pieces (Type B), bonded together with cold mastic or other material, as approved by the Engineer.

For expansion joint treatment where combined curb and gutter or gutter abuts a bridge wing on a U type abutment see bridge drawings.

Longitudinal joints shall be sawed and sealed with joint sealant, see Special Provisions for type.

"D" = Pavement thickness

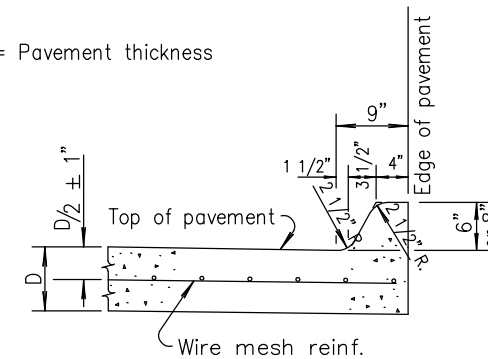

TYPICAL SECTION

6" OR 8" EDGE CURB (MONOLITHIC)

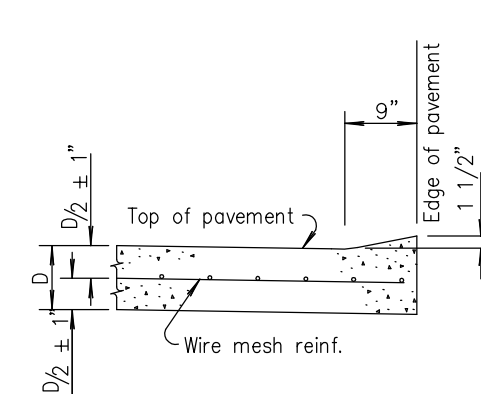

TYPICAL SECTION

1 1/2" EDGE CURB (MONOLITHIC)

Note: Planes of weakness are to be constructed over the contraction joints in the concrete pavement.

A 1" pre-moulded Expansion Joint Filler (Nonextruding, Type B) cut to the dimensions of the Edge Curb shall be used over the expansion joints in the concrete pavement.

EDGE CURB

NO.	DATE	REVISIONS	BY	APP'D
1	3-20-96	Del. Curb & Gutter Ref. to Br. Appr.	R.J.S.	J.O.B.
2	12-4-94	Rev. Joint Sealant	R.J.S.	J.O.B.
1	5-5-89	Rev. U type abut. note, GENERAL NOTE	R.J.S.	J.O.B.
10	10-15-87	Silicone joint sealant GENERAL NOTE	R.J.S.	J.O.B.
9	4-20-85	Note - U type abutments	W.L.H.	J.O.B.

KANSAS DEPARTMENT OF TRANSPORTATION

CURB, GUTTER AND

COMBINED CURB & GUTTER

RD635-

30 OF 89

FHWA APPROVAL	5-16-96	APP'D. James O. Brewer	TRACED Bowser
DESIGNED	DETAIL	QUANTITIES	TRACE CK. Seitz
DESIGN CK.	DETAIL CK.	QUAN. CK.	