

PLAN

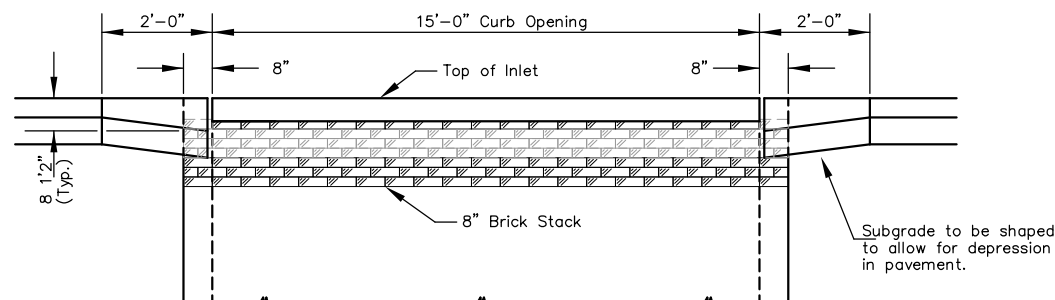

ELEVATION

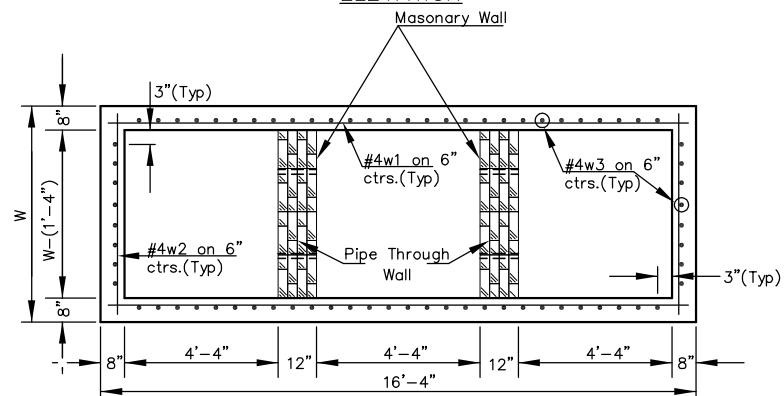

SECTION B-B

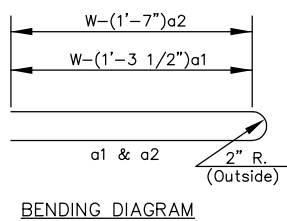

BENDING DIAGRAM

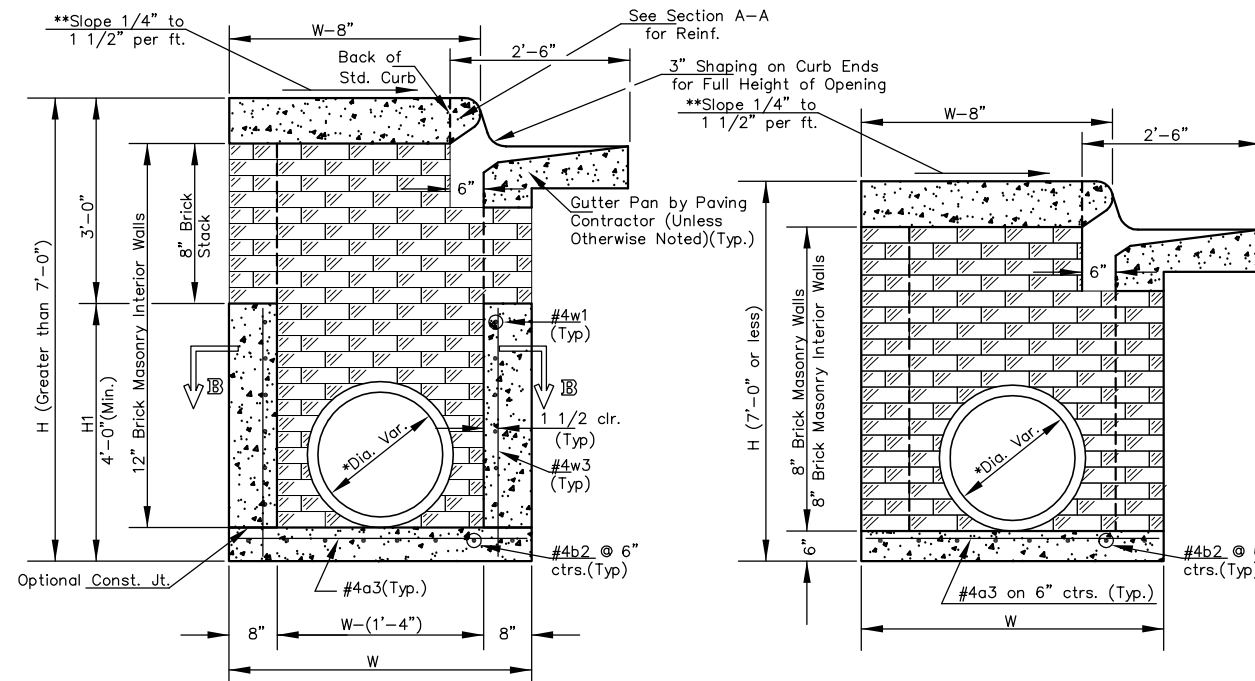

TYPICAL INLET SECTION AT INTERIOR WALL (Reinforced Concrete Walls)

TYPICAL INLET SECTION AT INTERIOR WALL (Masonry Walls)

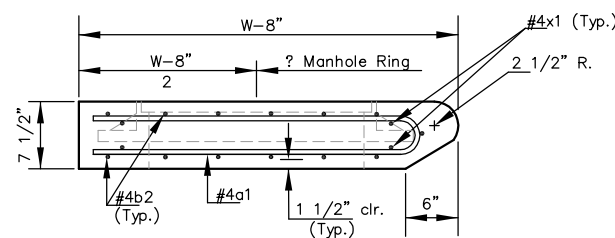

SECTION A-A

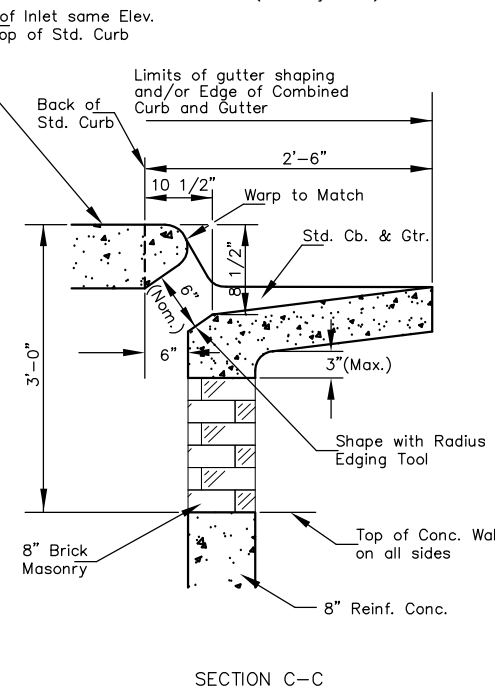

SECTION C-C

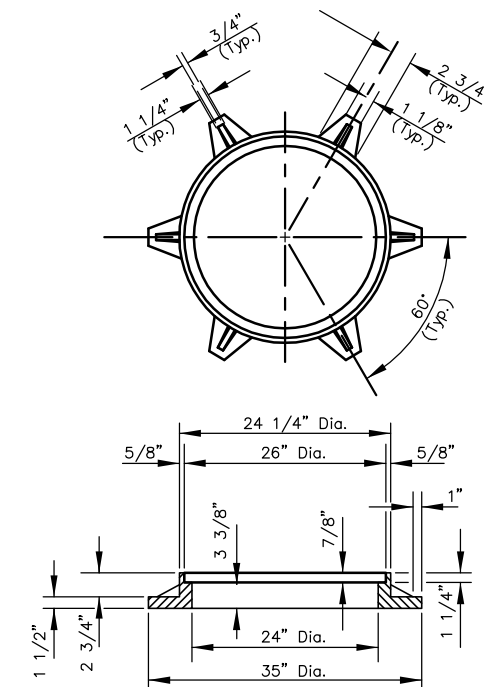

CAST IRON MANHOLE RING

Wt. 180 Lbs.

See City of Wichita Standard Manhole Frame and Cover Detail Sheet for Cover Details to be used with Inlet Frame.

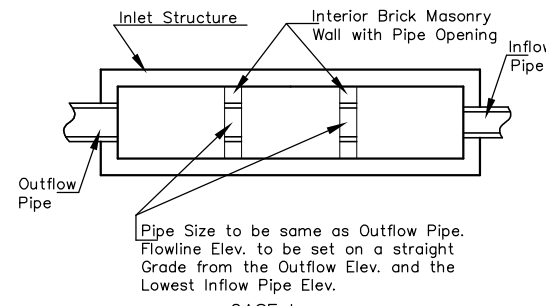

CASE I

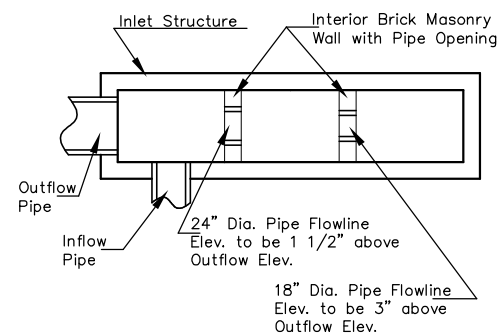

CASE II

NOTE: Interior Wall Pipe Size shall be as specified in the Inlet Construction Note on the Plan/Profile Sheets for those Cases not shown here.

GENERAL NOTES

1. THE CONTRACTOR SHALL BE REQUIRED TO CONSTRUCT 8" BRICK MASONRY WALLS BETWEEN THE CONCRETE INLET BASE AND TOP WHEN W = 6'-4" OR LESS AND H = 7'-0" OR LESS. WHEN 'W' IS GREATER THAN 6'-4" AND 'H' IS LESS THAN 7'-0", THE OUTSIDE INLET WALLS BELOW THE BRICK STACK SHALL BE REINFORCED CONCRETE CONSTRUCTION.
2. INLET INVERT SHALL BE SHAPED WITH 8 SACK SAND MIX CONCRETE TO CREATE FLOW CHANNELS AND TO INCREASE HYDRAULIC EFFICIENCY SUCH THAT THE INLET WILL BE SELF CLEANING BETWEEN ALL INLET AND/OR OUTLET PIPES.
3. CONCRETE SHALL BE C.O.W. STANDARD PAVING MIX. ALL EXPOSED EDGES SHALL BE FINISHED WITH AN EDGING TOOL. REINFORCING BARS SHALL BE FIELD BENT OR CUT TO CLEAR PIPES AND INLET RING. ALL BARS ARE #4 BARS AT 6" SPACING AND SHALL HAVE A MINIMUM CLEARANCE OF 1 1/2" UNLESS OTHERWISE NOTED.
4. CONCRETE TOPS TO BE INSTALLED ON THIN MORTAR CUSHION TO INSURE FULL SUPPORT ALONG BRICK WALLS. CONCRETE TOPS MAY BE CAST IN PLACE OR PRECAST.
5. THE ENDS OF ALL PIPES INSTALLED IN INLETS SHALL BE CUT OFF FLUSH WITH THE INSIDE FACE OF THE INLET WALL.

* An Interior Wall Opening shall be provided by means of a section of Reinforced Conc. Pipe. See CASE I and CASE II.
 ** Slope of Inlet Top to match Sidewalk or Parking Slope within the Limits indicated.

PRECAST SLAB AND FLOOR REINFORCING											
Mark	Size	W=4'-4"		W=5'-4"		W=6'-4"		W=7'-4"		W=8'-4"	
		No.	Length	No.	Length	No.	Length	No.	Length	No.	Length
?a1	#4	20	6'-7"	20	8'-7"	20	10'-7"	20	12'-7"	20	14'-7"
a2	#4	4	6'-0"	4	8'-0"	4	10'-0"	4	12'-0"	4	14'-0"
a3	#4	33	4'-1"	33	5'-1"	33	6'-1"	33	7'-1"	33	8'-1"
b1	#4	1	14'-9"	1	14'-9"	1	14'-9"	1	14'-9"	1	14'-9"
?b2	#4	23	16'-1"	29	16'-1"	35	16'-1"	41	16'-1"	47	16'-1"
x1	#4	24	3'-10"	24	4'-2"	24	4'-6"	24	4'-10"	24	5'-2"

WALL REINFORCING											
Mark	Size	W=4'-4"		W=5'-4"		W=6'-4"		W=7'-4"		W=8'-4"	
		No.	Length	No.	Length	No.	Length	No.	Length	No.	Length
w1	#4	1	16'-1"	1	16'-1"	1	16'-1"	1	16'-1"	1	16'-1"
w2	#4	1	4'-1"	1	5'-1"	1	6'-1"	1	7'-1"	1	8'-1"
w3	#4	72	2	76	2	80	2	84	2	88	2

? Field bend or cut Reinforcing as required for clearance.
 ① 4(HI-12"); (HI-12") Round down to nearest 0.5".
 ② HI-3"

STANDARD CURB INLET PRECAST TOPS			
W	PRE-CAST TOP SIZE	SIDE OF INTERIOR WALL PIPE SIZE	CU. YD. CONC.
4'-4"	3'-8"x16'-4"x7-1/2"	21" & Smaller	1.20±
5'-4"	4'-8"x16'-4"x7-1/2"	24" & 30"	1.58±
6'-4"	5'-8"x16'-4"x7-1/2"	36" & 42"	1.95±
7'-4"	6'-8"x16'-4"x7-1/2"	48" & 54"	2.33±
8'-4"	7'-8"x16'-4"x7-1/2"	60" & 66"	2.70±

THE CITY OF WICHITA

STANDARD TYPE 1 CURB INLET OPENING 6" x 15'-0"

J:\Civil\03392\dwg\details\TYPE1TRL.DWG 7/13/2004 3:16:18 PM CST

JIM ARMOUR, P.E. - CITY ENGINEER

PROJECT NUMBER 87 N-0307-01	INDEX CODE XXXXXX
DATE MAR 96	SHEET 36 OF 89

CITY ENGINEER'S OFFICE
CITY HALL - SEVENTH FLOOR
456 NORTH MAIN STREET
WICHITA, KANSAS 67202
(316) 268-4501
(316) 268-4114 FAX