

NOTE:

SPECIAL FINISH FOR TRAFFIC SIGNAL STRUCTURES: ALL EXTERIOR SURFACES ARE COATED WITH A ZINC RICH EPOXY POWDER TO A MINIMUM DRY FILM THICKNESS OF 2.0 MILS. THE COATING IS ELECTROSTATICALLY APPLIED AND PARTIALLY CURED IN A GAS FIRED CONVECTION OVEN BY HEATING THE STEEL SUBSTRATE TO A MINIMUM OF 250 DEGREES FAHRENHEIT.

THE POWDER PRIMED SURFACE IS COATED WITH AN INTERMEDIATE COAT OF POLYESTER POWDER TO A MINIMUM DRY FILM THICKNESS OF 2.0 MILS. THE COATING IS ELECTROSTATICALLY APPLIED AND CURED BY HEATING THE SUBSTRATE IN A CONVECTION OVEN TO A MINIMUM OF 350 DEGREES AND A MAXIMUM OF 400 DEGREES FAHRENHEIT.

THE INTERMEDIATE COAT IS TOP COATED WITH ONE COAT OF HIGH-BUILD ACRYLIC POLYURETHANE ENAMEL TO A MINIMUM DRY FILM THICKNESS OF 2.0 MILS. THE COATING IS ELECTROSTATICALLY APPLIED AND CURED BY HEATING THE SUBSTRATE IN A CONVECTION OVEN TO A MINIMUM OF 225 DEGREES FAHRENHEIT. THE FINAL TOP COATING COLOR SHALL BE BLACK.

THE COLOR OF EXTERIOR SURFACE OF ALL STRUCTURES, POLES, SIGNAL HEADS, BRACKETS, EQUIPMENT, CABINETS, COVERS, PANELS AND COMPONENTS SHALL BE MATCHING BLACK, UNLESS OTHERWISE NOTED.

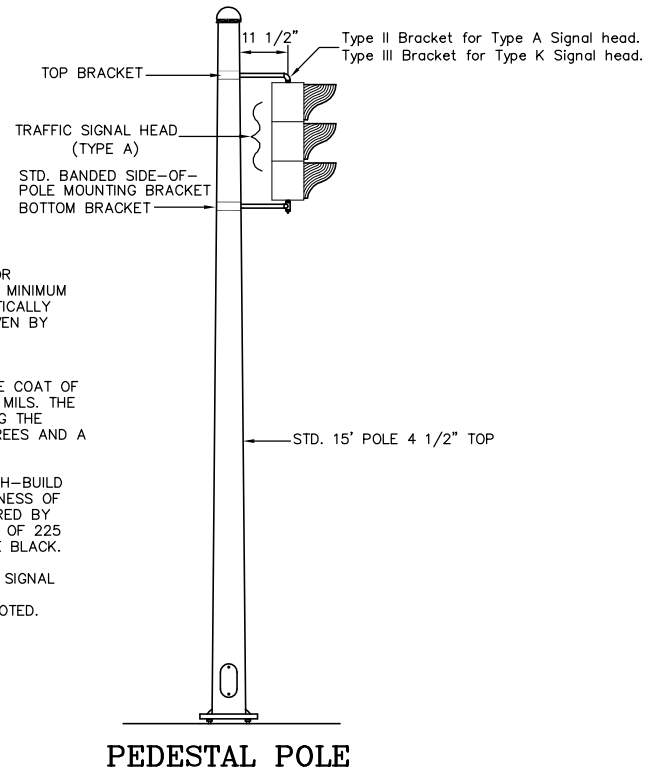
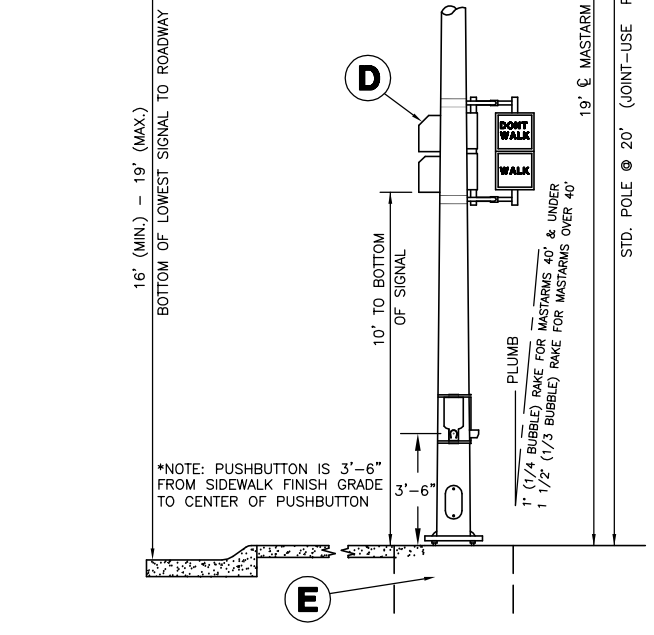

PEDESTAL POLE

BANDED SIGN MOUNTING BRACKET DETAIL

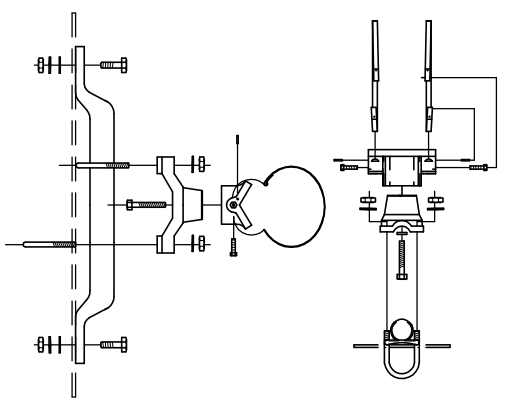

TYPE I SIGNAL MOUNTING BRACKET ASSEMBLY DETAIL

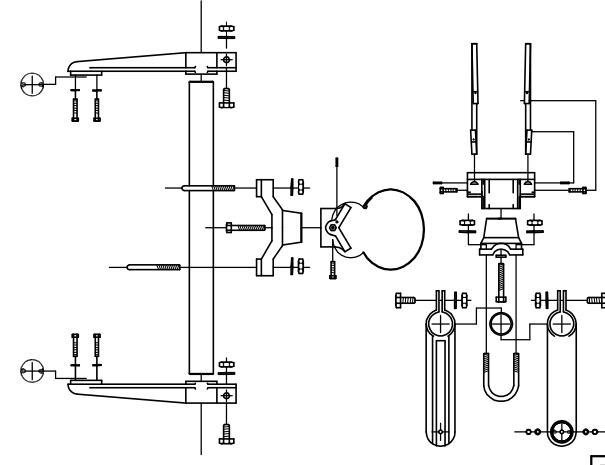

STANDARD SIGNING



CONCRETE BASE DETAILS PEDESTAL POLE

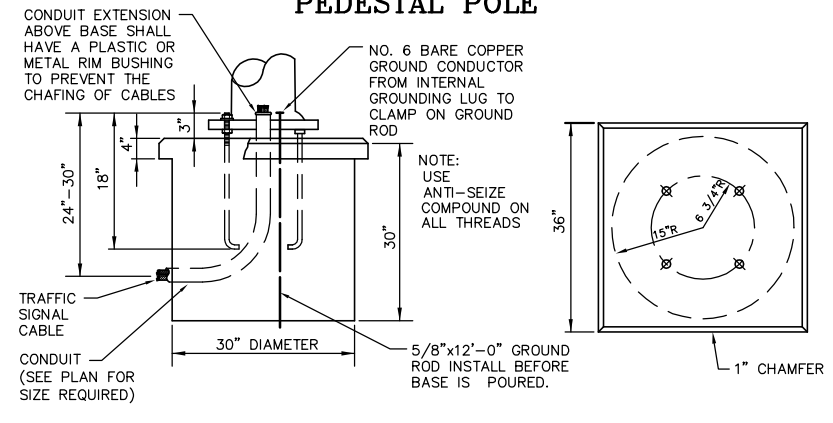

TYPE III SIDE-OF-POLE MOUNTING BRACKET ASSEMBLY

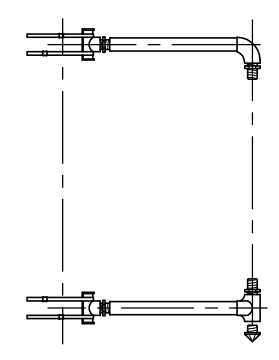

TYPE II SIDE-OF-POLE SIGNAL MOUNTING BRACKET ASSEMBLY

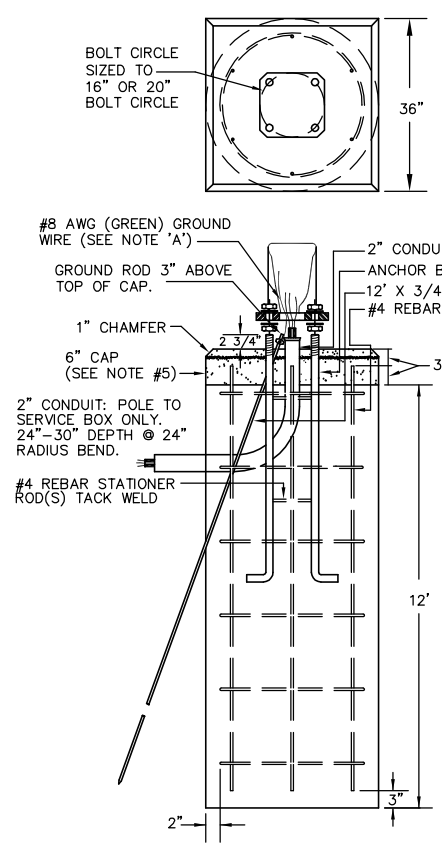
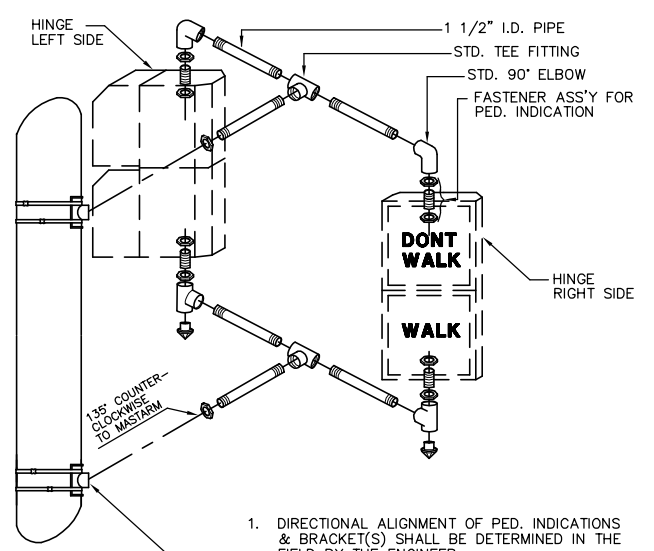

- NOTE:**
- THE ANCHOR BOLTS FOR THE SIGNAL POLE SHALL BE TACK WELDED TOGETHER IN A 16" OR 20" DIA. BOLT PATTERN (ON CENTERS AS SHOWN) TO MAINTAIN REQUIRED BOLT CONFIGURATION PATTERN AND TO AID IN VERTICAL POSITIONING WHILE CONCRETE BASE IS POURED.
 - USE ANTI-SEIZE COMPOUND ON ALL THREADS.
 - 12" x 3/4" GROUND ROD TO BE POSITIONED BEFORE POURING BASE.
 - CLASS 'A' CONCRETE SHALL BE USED TO CONSTRUCT BASE.
 - CONSTRUCT A 6" THICK x 36" SQUARE CONCRETE CAP AFTER POLE HAS BEEN ERECTED & PLUMBED. CHAMFER EDGE 1". MUST BE APPROVED BY ENG. BEFORE POURING.
 - CONDUIT SHALL HAVE PLASTIC (OR METAL) BUSHING (ABOVE BASE) TO PREVENT CABLE CHAFING.
 - USE #6 BARE COPPER GROUND CONDUCTOR FROM CLAMP TO GROUND BOLT IN ACCESS HOLE.

REBAR CAGE

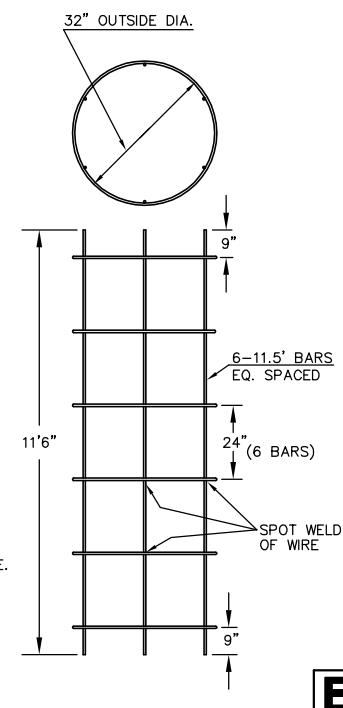

J:\CIVIL\03392\DWG\DETAILS\SSP-DTL.DWG

PROJECT DESCRIPTION

STEEL SIGNAL POLE ASSEMBLY DETAILS

PROJECT NUMBER: 87 N-0307-01

DATE: FEB. 96

APPROVED BY: [Signature]

REVISD BY: T.M.

DATE: MAY, 97

CITY OF WICHITA
DEPARTMENT OF PUBLIC WORKS

DIVISION OF TRAFFIC ENGINEERING

PAUL GUNZELMAN P.E. TRAFFIC ENGINEER

SCALE: NO SCALE

53/89 SHEET / OF