

STATE	PROJECT NO.	YEAR	SHEET NO.	TOTAL SHEETS
KANSAS	87 N-0307-01	2006	67	89

1. MUTCD COMPLIANCE:
ALL TRAFFIC CONTROL DEVICES AND THEIR INSTALLATION AND MAINTENANCE SHALL COMPLY WITH THE REQUIREMENTS OF THE MANUAL ON UNIFORM TRAFFIC CONTROL DEVICES (MUTCD) FOR STREETS AND HIGHWAYS. WHENEVER THE TRAFFIC CONTROL STANDARDS CONFLICT WITH THE MANUAL, THE STANDARDS SHALL GOVERN.

2. DESIGN SPEED:
TRAFFIC CONTROL SHOULD BE DESIGNED AND INSTALLED USING THE POSTED/LEGAL SPEED OF THE ROADWAY PRIOR TO WORK STARTING.

3. CLEAR ZONE:
ALL CONSTRUCTION EQUIPMENT (INCLUDING VEHICLES), MATERIALS, AND DEBRIS SHALL BE STORED OUT OF THE CLEAR ZONE. WHERE THIS CANNOT BE ACHIEVED, THE CONTRACTOR SHALL PLACE APPROPRIATE SIGNS, OBJECT IDENTIFIERS, AND/OR BARRICADES AS DESIGNATED BY THE ENGINEER. TRAFFIC CONTROL DEVICES NEEDED FOR THIS CONDITION SHALL BE CONSIDERED SUBSIDIARY TO OTHER BID ITEMS.

4. MINIMUM LANE WIDTHS:
LANE WIDTHS SHALL BE A MINIMUM OF 11' (MEASURED BETWEEN CENTERLINES OF PAVEMENT MARKINGS) OR AS SHOWN ON THE PLANS, OR AS DIRECTED BY THE ENGINEER. A LANE WIDTH LESS THAN 11' MAY REQUIRE RESTRICTED ROADWAY WIDTH SIGNING.

5. FLAGGER:
A MINIMUM OF ONE FLAGGER SHALL BE STATIONED WITHIN EACH MULTI-LANE ROADWAY WORK AREA WHERE WORK IS IN A CLOSED LANE ADJACENT TO TRAFFIC AND NOT SEPERATED BY CONCRETE SAFETY BARRIER.

6. PAVEMENT MARKING:
ALL CONFLICTING PAVEMENT MARKINGS SHALL BE REMOVED OR MASKED. WHEN THE WORK WILL OCCUPY A LOCATION MORE THAN THREE DAYS, ALL TRANSITION TAPERS, CROSSOVERS, AND EDGE LINES ALONG CHANNELIZING DEVICES SHALL BE MARKED WITH SOLID 4" WIDE PAVEMENT MARKING.

7. FIRST MODULE OF IBS:
THE FIRST MODULE OF EACH INERTIAL BARRIER SYSTEM (IBS) SHALL HAVE A MINIMUM OF 2 SQ. FT. OF FLOURESCENT ORANGE PRISMATIC GRADE RETROREFLECTIVE SHEETING FACING TRAFFIC. EITHER A VERTICAL RECTANGLE OR DIAMOND SHAPE MAY BE USED.

8. PEDESTRIAN / BICYCLE SAFETY:
WORK ZONE SIGNS SHALL NOT INHIBIT PEDESTRIAN AND BICYCLE TRAFFIC ON SIDEWALKS OR OTHER AREAS DESIGNATED FOR PEDESTRIAN OR BICYCLE USE.

CONSIDERATION SHOULD BE MADE TO SEPERATE PEDESTRIAN AND BICYCLE MOVEMENTS FROM BOTH WORK SITE ACTIVITY AND MOTOR VEHICLE TRAFFIC. PEDESTRIANS AND BICYCLISTS SHOULD BE APPROPRIATELY DIRECTED WITH ADVANCE SIGNING THAT ENCOURAGES THEM TO CROSS TO THE OPPOSITE SIDE OF THE ROADWAY. IN URBAN AND SUBURBAN AREAS WITH HIGH MOTOR VEHICLE TRAFFIC VOLUMES, THESE SIGNS SHOULD BE PLACED AT INTERSECTIONS SO THAT PEDESTRIANS AND BICYCLISTS ARE NOT CONFRONTED WITH MID-BLOCK WORK SITES THAT WILL INDUCE THEM TO ATTEMPT SKIRTING THE WORK SITE OR MAKING A MID-BLOCK CROSSING.

9. CHANGED STOP CONDITIONS:
ATTACH TWO FLAGS AND A RED TYPE B HIGH INTENSITY WARNING LIGHT TO ANY STOP SIGN THAT CREATES A NEW STOP CONDITION OR MOVES THE STOP CONDITION TO A NEW LOCATION. LEAVE FLAGS AND LIGHTS IN PLACE FOR AT LEAST THE FIRST 30 DAYS. INSTALL W3-1a (SYMBOLIC STOP AHEAD) SIGN IN ADVANCE OF STOP SIGN IF STOP SIGN IS NOT VISIBLE FOR A MINIMUM OF DISTANCE 'A' (SEE CHART ON TE710) OR IF STOP CONDITION IS MOVED TO LESS THAN DISTANCE 'A' FROM AN EXISTING STOP AHEAD SIGN.

10. LUMP SUM BIDDING:
WHEN TRAFFIC CONTROL IS BID LUMP SUM, ADDITIONAL DEVICES WILL BE PAID FOR AS EXTRA WORK.

11. NIGHT TIME LIGHTING:
WHEN NIGHTTIME WORK IS REQUIRED, FLOODLIGHTS SHOULD BE USED TO ILLUMINATE FLAGGER STATIONS, EQUIPMENT CROSSINGS, AND OTHER AREAS WHERE EXISTING LIGHT IS NOT ADEQUATE FOR THE WORK TO BE PERFORMED SAFELY.

IN NO CASE SHALL FLOODLIGHTS BE PERMITTED TO CREATE A DISABLING GLARE FOR THE DRIVER. THE ADEQUACY OF THE FLOODLIGHT PLACEMENT AND ELIMINATION OF POTENTIAL GLARE SHOULD BE CHECKED BY DRIVING THROUGH THE PROJECT.

12. NCHRP REPORT 350 CRASHWORTHY REQUIREMENTS:
TRAFFIC CONTROL DEVICES SHALL MEET THE EVALUATION CRITERIA IN NCHRP REPORT 350 AS SUPPLEMENTED BY FHWA MEMORANDUM "IDENTIFYING ACCEPTABLE HIGHWAY SAFETY FEATURES," DATED JULY 25, 1997. AVAILABLE ON THE INTERNET AT http://safety.fhwa.dot.gov/fourthlevel/pro_res_road_nchrp350.htm.

THE CONTRACTOR SHALL:
1) PROVIDE TO THE ENGINEER A COPY OF THE MANUFACTURER'S SELF-CERTIFICATION THAT ANY CATEGORY 1 (i.e. - PLASTIC TRIMLINE CONES, TUBULAR MARKERS, DRUMS WITHOUT ATTACHMENTS) AND CATEGORY 2 (i.e. - PORTABLE SIGN STANDS (WITH SIGNS), TYPE II AND III BARRICADES, AND VERTICAL PANELS) DEVICES USED ON THE PROJECT ARE NCHRP REPORT 350 COMPLIANT.

2) PROVIDE TO THE ENGINEER, UPON REQUEST, A COPY OF THE ENTIRE FHWA NCHRP REPORT 350 ACCEPTANCE LETTER (WZ-xxx) FOR ANY CATEGORY 2 DEVICE (i.e. - PORTABLE SIGN STANDS (WITH SIGNS), TYPE II AND III BARRICADES, AND VERTICAL PANELS) USED ON THE PROJECT. WORK ZONE FHWA NCHRP REPORT 350 ACCEPTANCE LETTERS (WZ-xxx) ARE AVAILABLE ON THE INTERNET AT <http://safety.fhwa.dot.gov/fourthlevel/hardware/listing.cfm?code=workzone>.

3) CERTIFY THAT THE TRUCK MOUNTED ATTENUATORS (TMA'S) (WHICH ARE DEFINED AS CATEGORY 3 DEVICES BY THE FHWA MEMORANDUM) WERE PURCHASED PRIOR TO OCTOBER 1, 1998, AND INCLUDE A COPY OF THE ENTIRE FHWA ACCEPTANCE LETTER STATING THAT THE TMA'S ARE NCHRP REPORT 230 COMPLIANT; OR IF THE DEVICES WERE PURCHASED AFTER OCTOBER 1, 1998, INCLUDE A COPY OF THE ENTIRE FHWA'S ACCEPTANCE LETTER STATING THAT THE TMA'S ARE NCHRP REPORT 350 COMPLIANT.

ALL CATEGORY 1 & 2 DEVICES USED ON PROJECTS LET AFTER JANUARY 1, 2002 SHALL BE NCHRP REPORT 350 COMPLIANT. TMA'S PURCHASED PRIOR TO OCTOBER 1, 1998, MAY BE USED UNTIL THE END OF THEIR SERVICEABLE LIVES.

BUFFER SPACE:

SPEED (MPH)*	20	25	30	35	40	45	50	55	60	65	70
LENGTH (ft)	35	50	85	115	165	215	280	330	410	500	575

NEITHER WORK ACTIVITY NOR STORAGE OF EQUIPMENT, VEHICLES, OR MATERIAL SHOULD OCCUR IN THE BUFFER SPACE. WHEN A PROTECTION VEHICLE IS PLACED IN ADVANCE OF THE WORK SPACE, ONLY THE SPACE UPSTREAM OF THE VEHICLE CONSTITUTES THE BUFFER SPACE.

* POSTED SPEED PRIOR TO WORK STARTING

IF TEMPORARY CONCRETE SAFETY BARRIER IS USED TO SEPERATE APPROACHING TRAFFIC FROM THE WORK ACTIVITY, THE BARRIER SHALL BE CONSIDERED PART OF THE WORK AREA. A FULL LANE WIDTH SHOULD BE AVAILABLE THROUGHOUT THEN LENGTH OF THE BUFFER SPACE. FOR EXAMPLE:

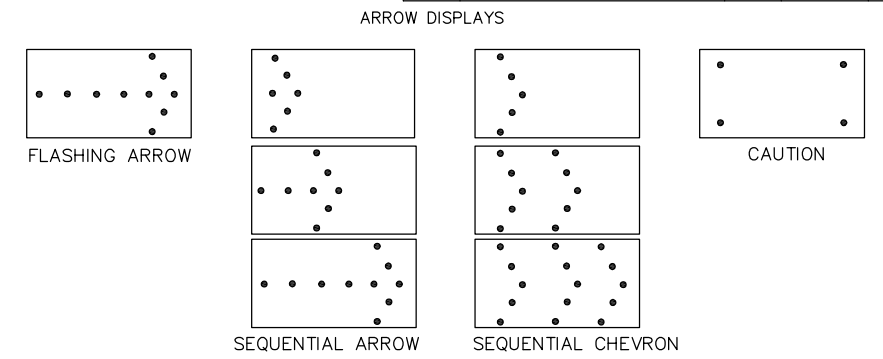
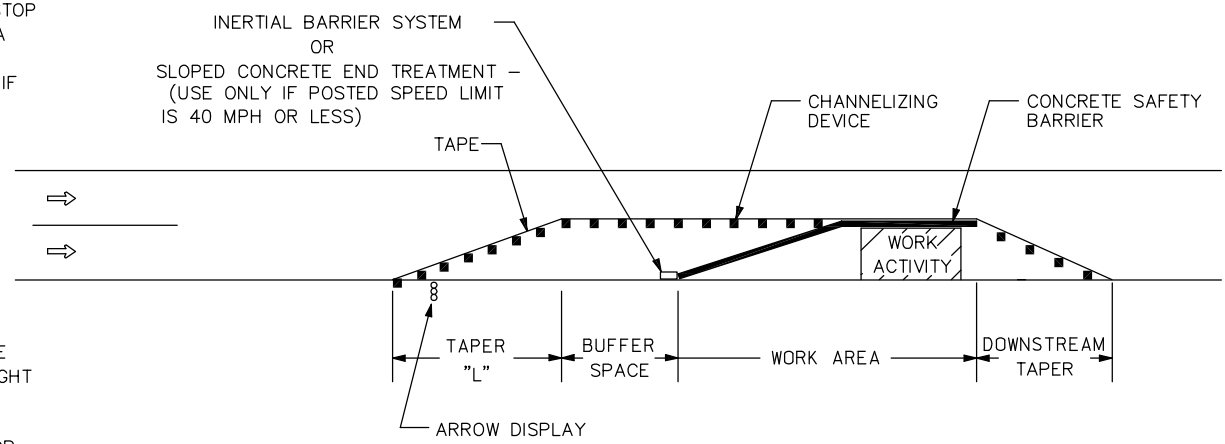

ARROW DISPLAY ELEMENTS SHALL BE CAPABLE OF A MINIMUM 50 PERCENT DIMMING FROM THEIR FULL-RATED LAMP VOLTAGE. FULL LAMP VOLTAGE SHOULD BE USED FOR DAY AND DIMMED MODE SHALL BE USED FOR NIGHT. AN ARROW DISPLAY IN THE CAUTION MODE SHALL BE USED ONLY FOR SHOULDER WORK OR ROADSIDE WORK NEAR THE SHOULDER.

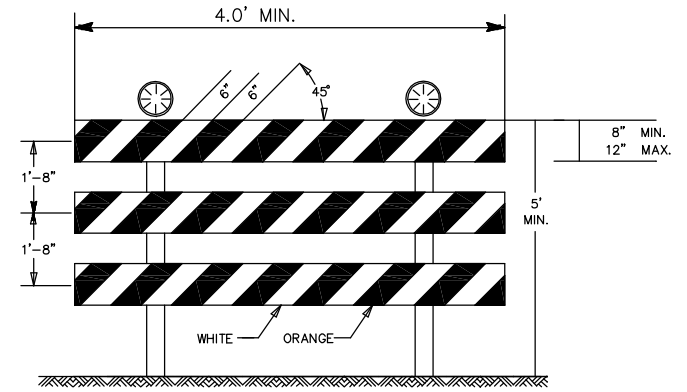

BARRICADES:
WHEN CLOSING A ROAD, TYPE III BARRICADES SHALL BE PLACED END-TO-END TO SUFFICIENTLY COVER THE ROADWAY. WHEN AUTHORIZED ACCESS MUST BE ALLOWED, THE BARRICADES SHALL BE LONGITUDINALLY STAGGERED TO MAINTAIN THE APPEARANCE OF A CLOSED ROADWAY. IF THE ACCESS IS FOR CONSTRUCTION VEHICLES, THE BARRICADES SHALL BE REALIGNED TO DENY ANY ACCESS WHEN THE CONSTRUCTION ACTIVITY HAS CEASED FOR THE DAY. IF THE ACCESS IS FOR LOCAL TRAFFIC, THE BARRICADES SHALL REMAIN LONGITUDINALLY STAGGERED AND A SECOND LINE OF END-TO-END BARRICADES SHALL BE PLACED AT THE WORK AREA TO CLOSE THE ROAD

FOR WOODEN BARRICADES, NOMINAL LUMBER DIMENSIONS WILL BE SATISFACTORY.

THE ENTIRE AREA OF BARRICADE RAILS, BOTH FRONT AND BACK, SHALL BE FULLY REFLECTORIZED WITH TYPE III HIGH PERFORMANCE RETROREFLECTIVE SHEETING.

THE STRIPES SHALL SLOPE DOWNWARD TO THE SIDE TRAFFIC IS TO PROCEED OR TOWARD THE CENTER OF THE ROADWAY AT ROAD CLOSURES.

SIGNS MOUNTED ON TYPE III BARRICADES SHOULD NOT COVER MORE THAN 50% OF THE TOP TWO RAILS OR 33% OF THE TOTAL AREA OF THE THREE RAILS.

A MINIMUM OF TWO TYPE A LIGHTS SHALL BE USED AT EACH LOCATION WHERE A TYPE III BARRICADE OR BARRICADES ARE USED. A LIGHT SHALL BE MOUNTED ON THE OUTSIDE CORNER OF THE END BARRICADES WHEN MORE THAN ONE BARRICADE IS USED.

WARNING LIGHTS SHALL COMPLY WITH THE CURRENT ITE PURCHASE SPECIFICATIONS FOR FLASHING AND STEADY BURN WARNING LIGHTS. THE LENS SHALL BE A MINIMUM OF 7 INCHES IN DIAMETER AND BE MOUNTED AT A MINIMUM HEIGHT OF 5 FEET.

TYPE A LOW INTENSITY FLASHING WARNING LIGHTS SHALL BE MAINTAINED SO AS TO BE CAPABLE OF BEING VISIBLE ON A CLEAR NIGHT FROM A DISTANCE OF 3000 FEET.

3	11-19-03	CHANGED BORDER	B.H.	S.A.B.
2	3-17-03	MODIFIED NOTE 12	M.H.	S.A.B.
1	9-26-02	MODIFIED NOTES	M.H.	S.A.B.
NO.	DATE	REVISIONS	BY	APP'D

KANSAS DEPARTMENT OF TRANSPORTATION
GENERAL TRAFFIC CONTROL

TE700		67 OF 89	
FHWA APPROVAL 11-26-2003	APP'D Michael P. McKenna	DESIGNED L.E.R.	TRACED
DESIGN CK.	DETAIL CK.	QUANTITIES	TRACE CK.