

LONGITUDINAL SECTION

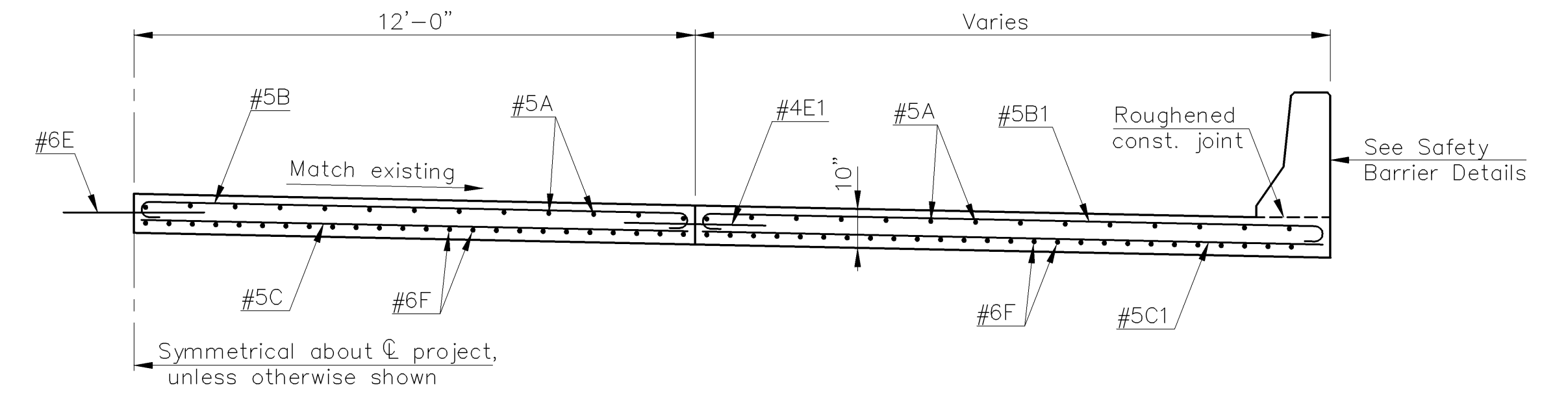

HALF TRANSVERSE SECTION

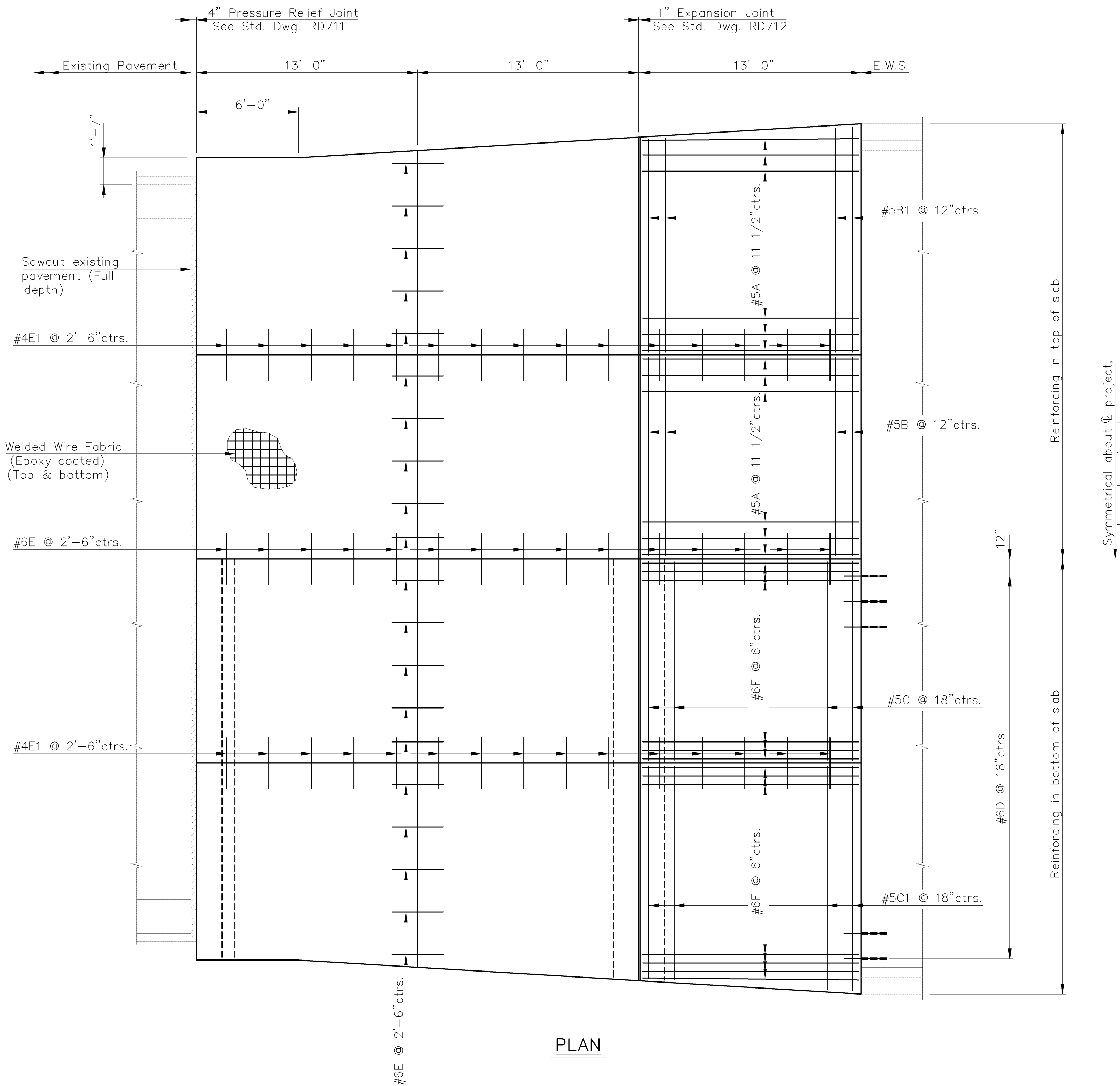

PLAN

GENERAL NOTES

Special Concrete Bridge Approach shall be paid for as square yards of Concrete Pavement (10" Unif.)(AE) and includes all work and materials required to construct the approach slab and sleeper slab as shown on this sheet.

All work and materials required for installation of expansion joints and pressure relief joints shall be subsidiary to this bid item.

All preformed joint material shall be installed perpendicular to pavement surface. Formed joints shall be edged with a 1/4" radius tool for length of joint.

At the Contractors option, #4 X 3'-0" tie bars at 15" centers may be substituted for the #6E bars at 2'-6" centers.

All reinforcing shall be epoxy coated.

See Std. Dwg. RD711 and RD712 for details of joints and reinforcing mesh.

Clearance from the face of concrete for all reinforcing steel shall be 2", unless otherwise shown.

Standard reinforcing bar hooks in accordance with the latest ACI specifications shall be used throughout.

It is recommended that the Contractor confirm the the dimensions of the existing bridge and pavement in the field prior to ordering reinforcing and joint material.

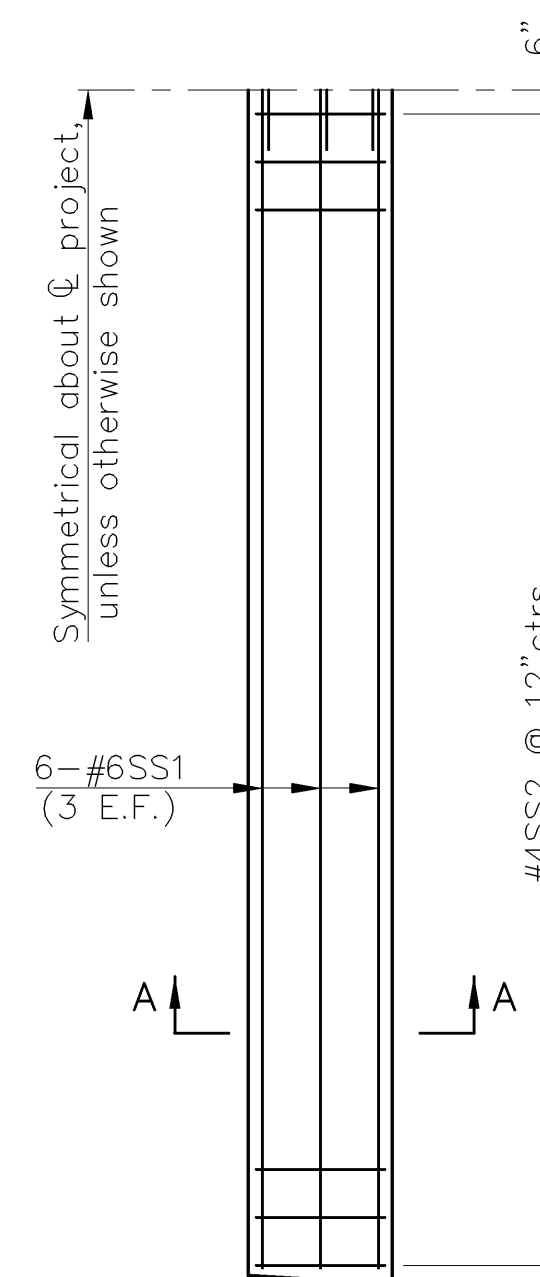

SLEEPER SLAB

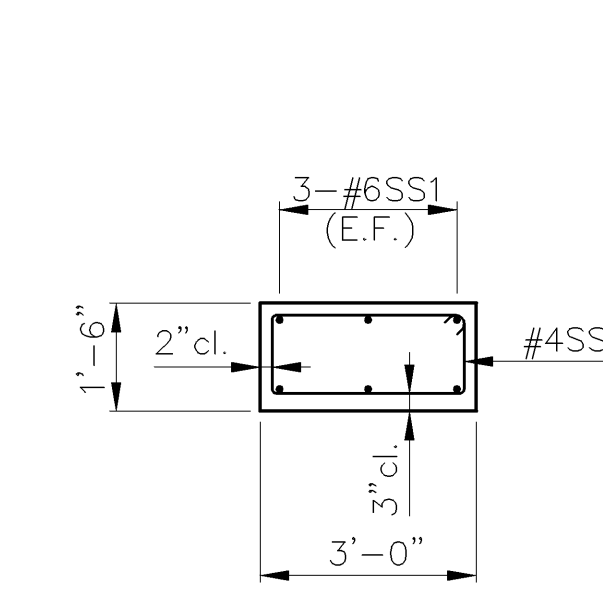

SECTION A-A

Note: E.F. Indicates each face

BILL OF REINFORCING STEEL							
STRAIGHT BARS				BENT BARS			
Mark	Size	No.	Length	Mark	Size	No.	Length
E	#6	35	3'-0"	D	#6	32	3'-1"
SS1	#6	12	25'-10"	F	#6	100	13'-4"
A	#5	54	12'-8"	B	#5	26	12'-10"
C	#5	18	11'-8"	B1	#5	26	Varies
C1	#5	18	Varies	SS2	#4	50	8'-3"
E1	#4	30	3'-0"				

BENDING DIAGRAMS

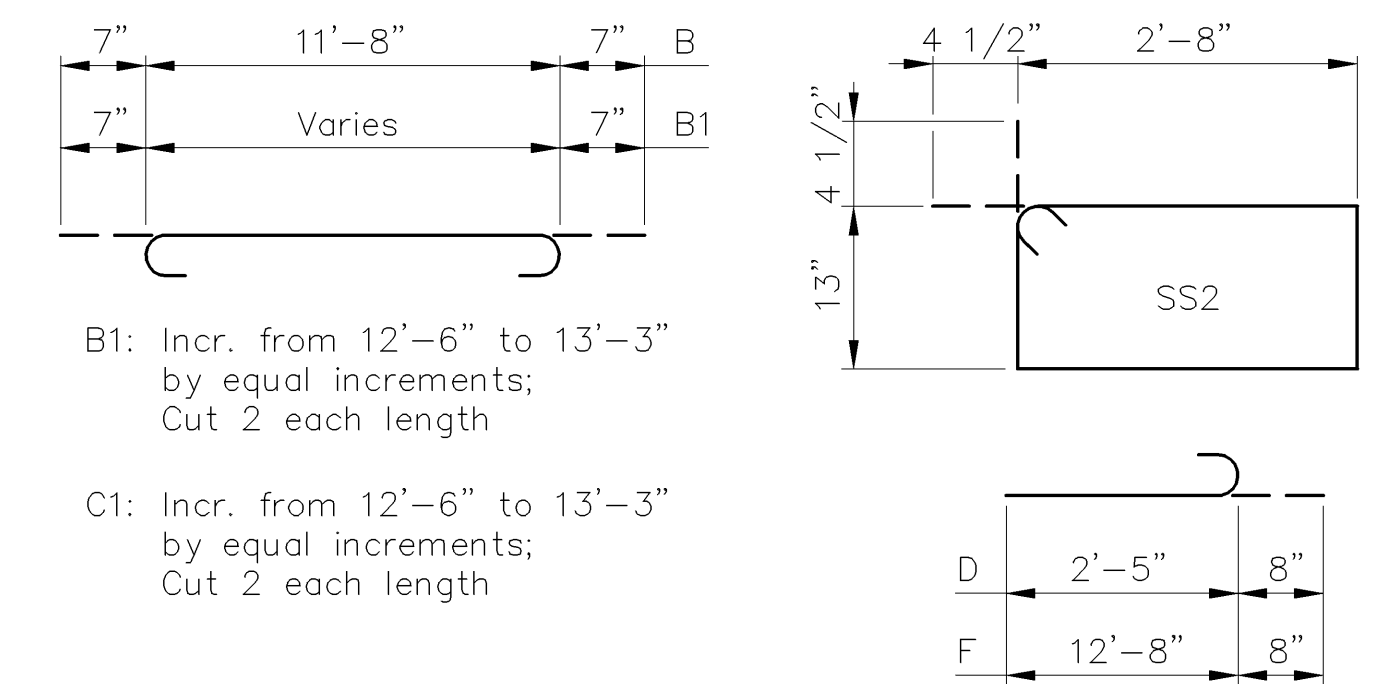

B1: Incr. from 12'-6" to 13'-3" by equal increments; Cut 2 each length

C1: Incr. from 12'-6" to 13'-3" by equal increments; Cut 2 each length

BILL OF MATERIALS		
Concrete Pavement (10" Unif.)(AE)	212.1	Sq. Yds.
Grade 4.5 Concrete (AE)(SW)	70.7	Cu. Yds.
Reinforcing Steel (Gr. 60) (Epoxy Coated)	6,460	Lbs.
Expansion Joint	49.6	Lin. Ft.
4" Pressure Relief Joint	45.0	Lin. Ft.

Note: Concrete, reinforcing steel and joint lengths are shown for information only. Sleeper slabs shall not be paid for directly but shall be subsidiary to the bid item "Concrete Pavement (10" Unif.)(AE)".

PROJECT NO. 87 N-0247-01		 Cook, Flatt & Strobel ENGINEERS, P.A.
CONCRETE APPROACH PAVEMENT (SOUTH APPROACH) OLIVER ST. BRIDGE OVER GYPSUM CREEK		
DESIGNED	RSC	SCALE
DETAILED	DEG	DATE
QUANTITIES		SHEET OF