

EXPANSION JOINT

NOTE: Extra Thickness to be Substituted to Price of Square Yards Pavement

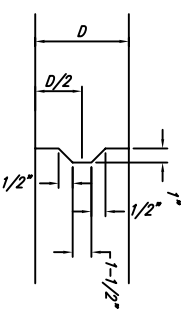

KEYWAY DETAIL

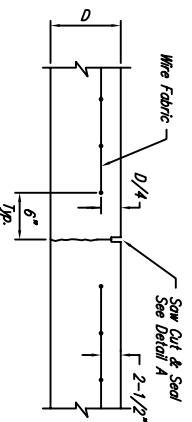

CONTRACTION JOINT DETAIL (C.J.)

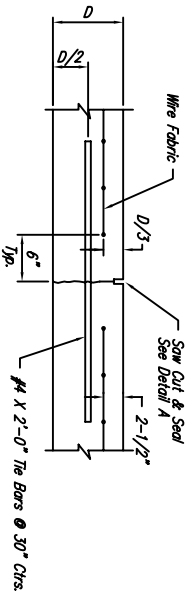

LONGITUDINAL JOINT DETAIL (L.J.)

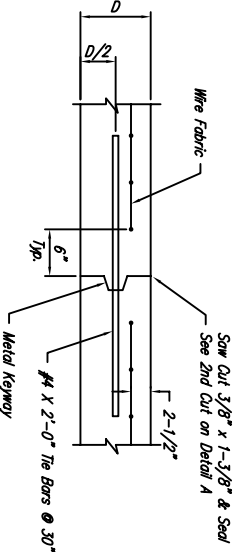

OPTIONAL LONGITUDINAL JOINT DETAIL (L.J.)

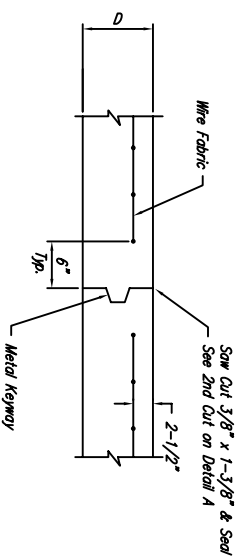

OPTIONAL CONTRACTION JOINT

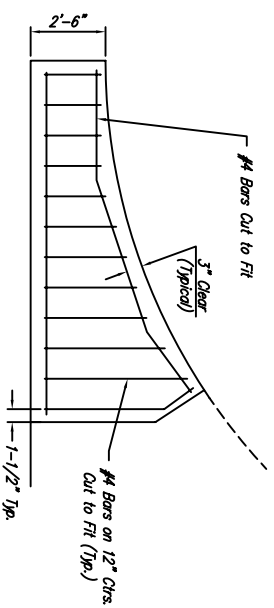

WING REINFORCING DETAIL

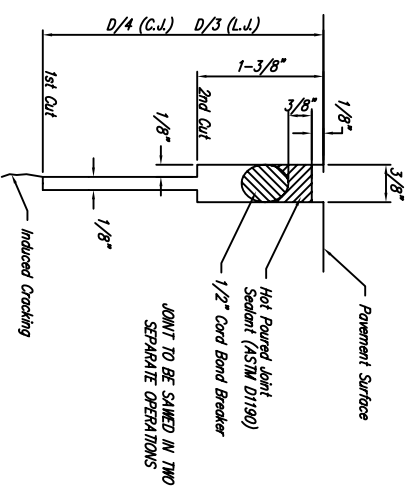

SAW JOINT DETAIL

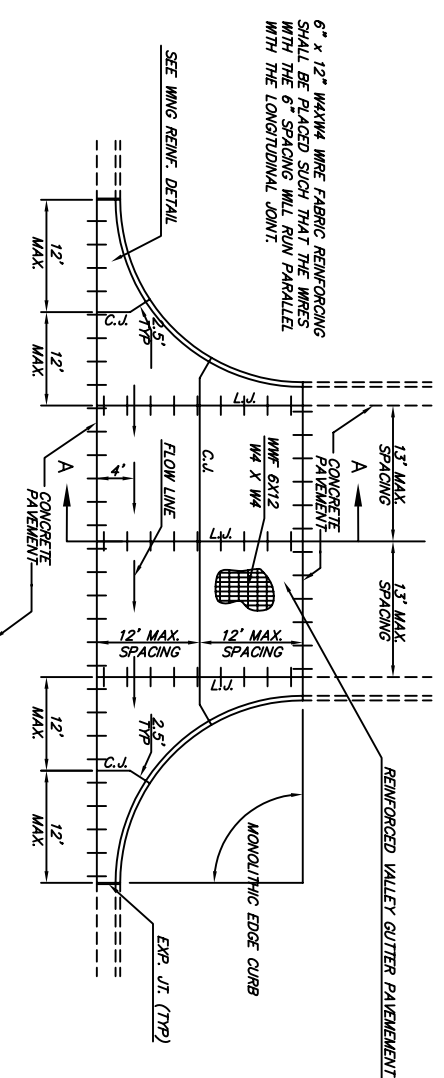

PLAN

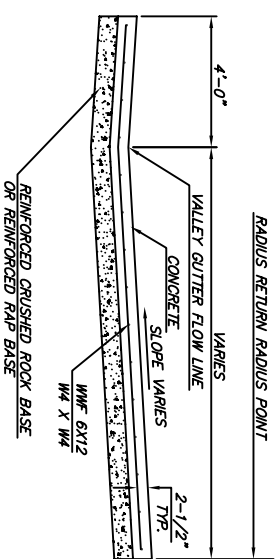

SECTION A-A

REINFORCED VALLEY GUTTER DETAIL

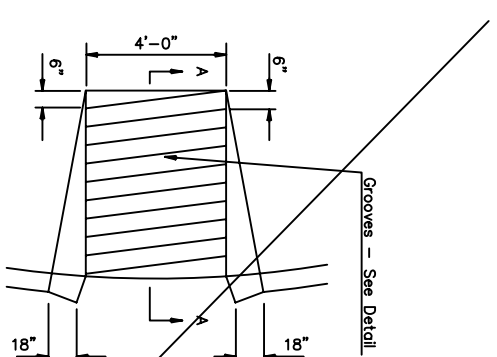

WHEELCHAIR RAMP PLAN VIEW

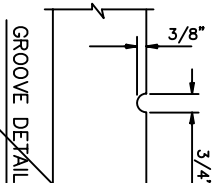

GROOVE DETAIL

WHEELCHAIR RAMP DETAIL

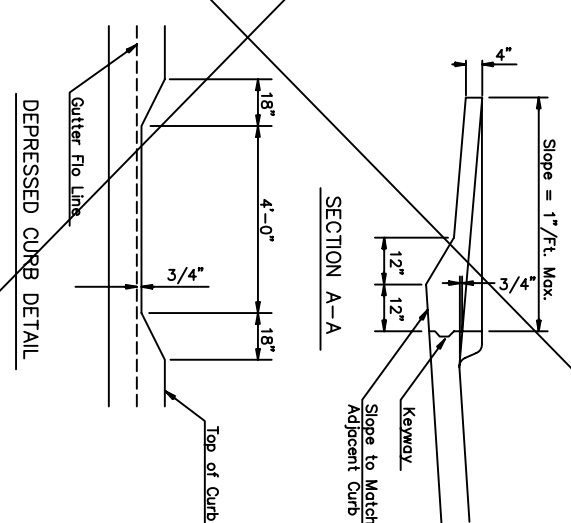

SECTION A-A

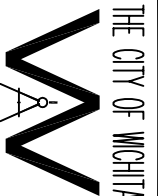
THE CITY OF WICHITA
 CITY ENGINEER'S OFFICE
 CITY HALL - SEVENTH FLOOR
 1001 NORTH WALKER STREET
 WICHITA, KANSAS 67202
 (316) 241-1114 Fax

VALLEY GUTTER DETAILS
WHEELCHAIR RAMP DETAILS

JAMES L. ARMOUR P.E. - CITY ENGINEER
 PROJECT NUMBER: 87N-0237-01
 DATE: MAR 96
 SHEET 22 OF 78