

EXPANSION JOINT

NOTE: Extra Thickness to be Subsidiary to Price of Square Yards Pavement

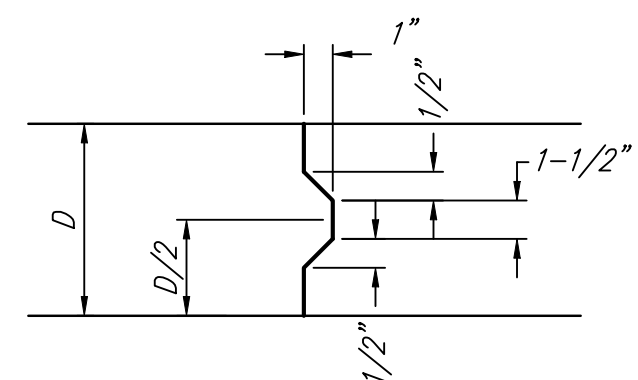

KEYWAY DETAIL

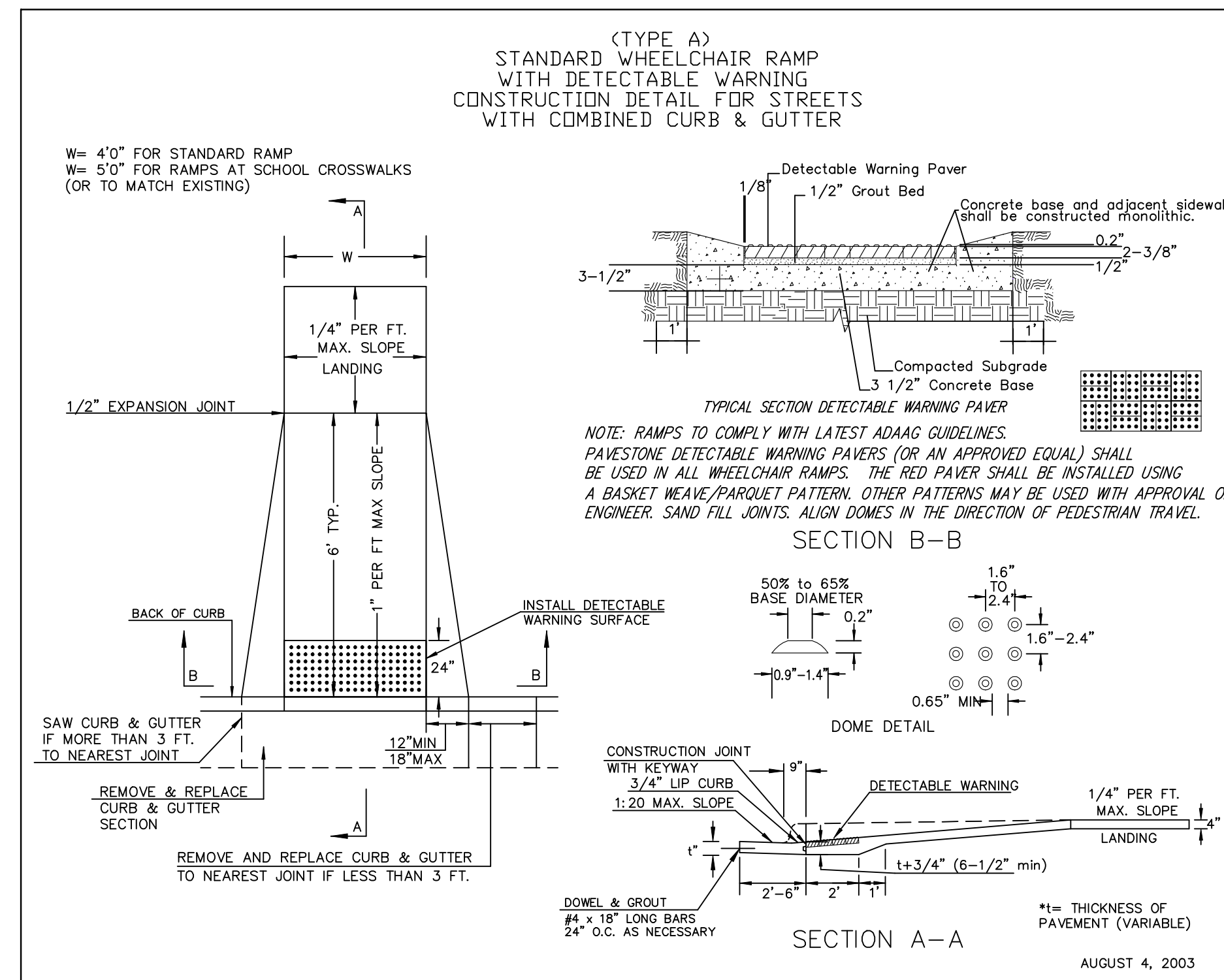

WHEELCHAIR RAMP DETAIL

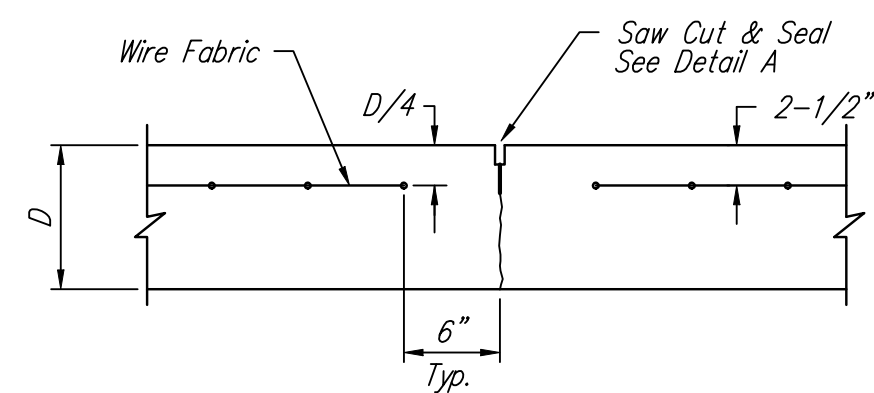
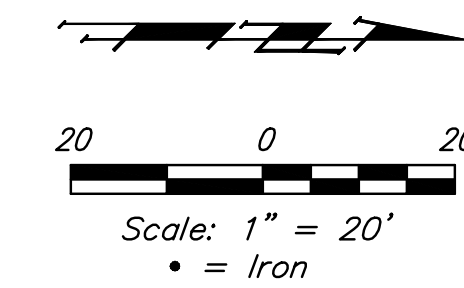

CONTRACTION JOINT DETAIL (C.J.)

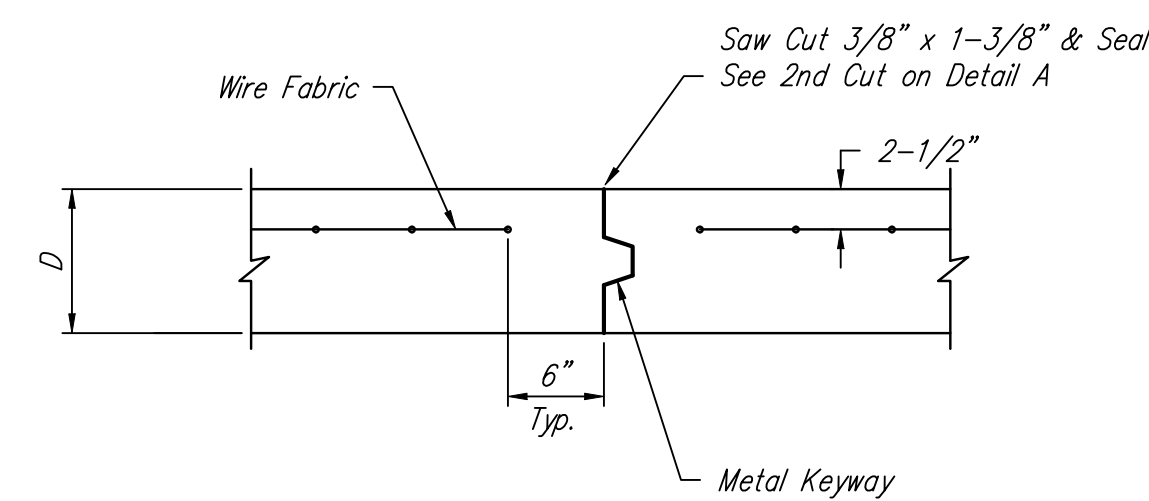

OPTIONAL CONTRACTION JOINT (CONSTRUCTION JOINT)

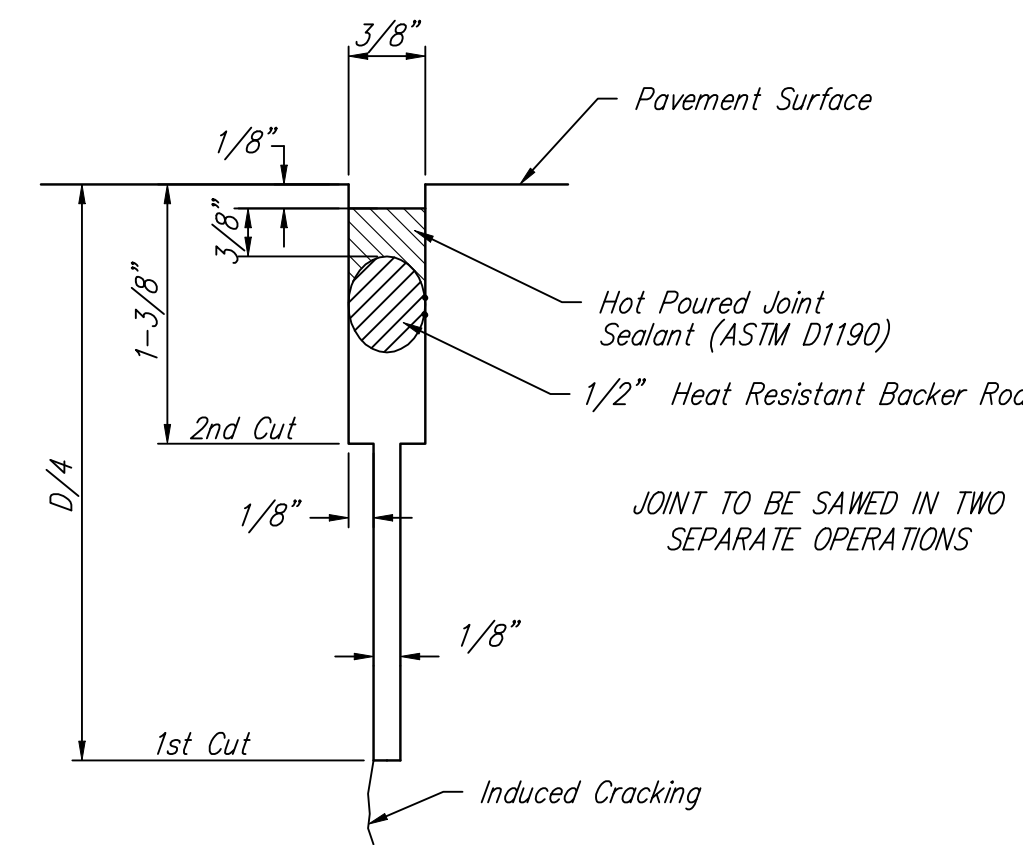

SAW JOINT DETAIL "A"

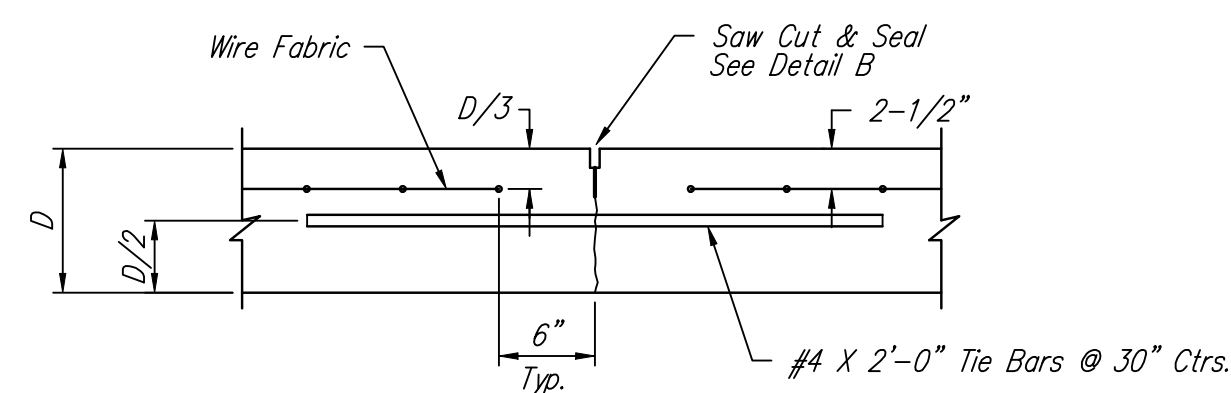
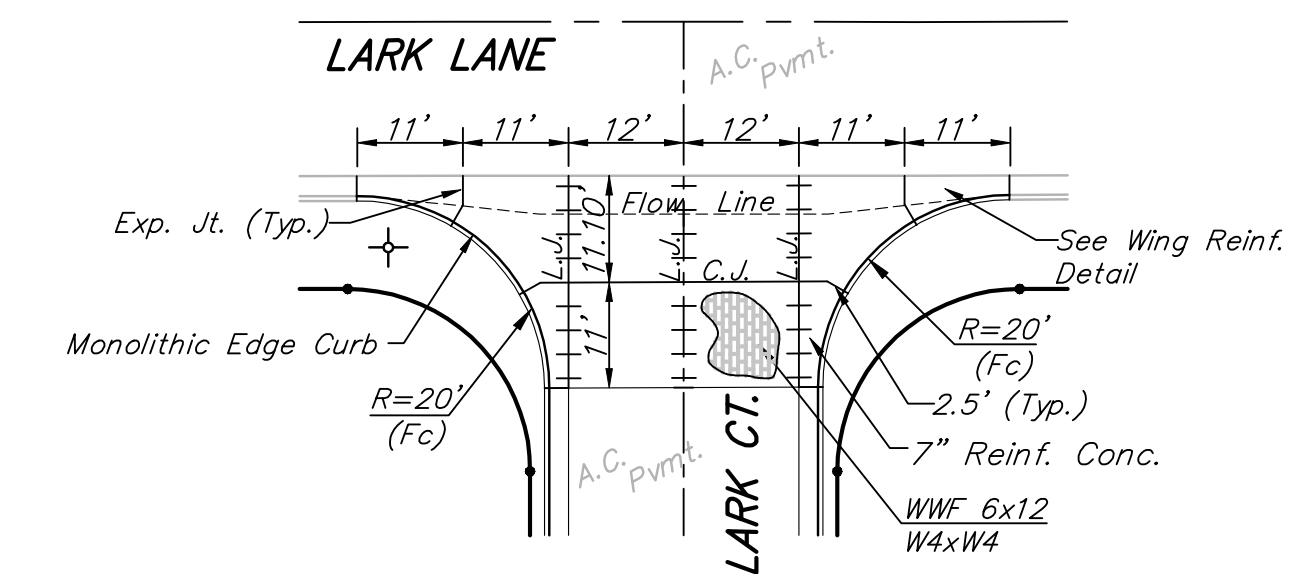

LONGITUDINAL JOINT DETAIL (L.J.)

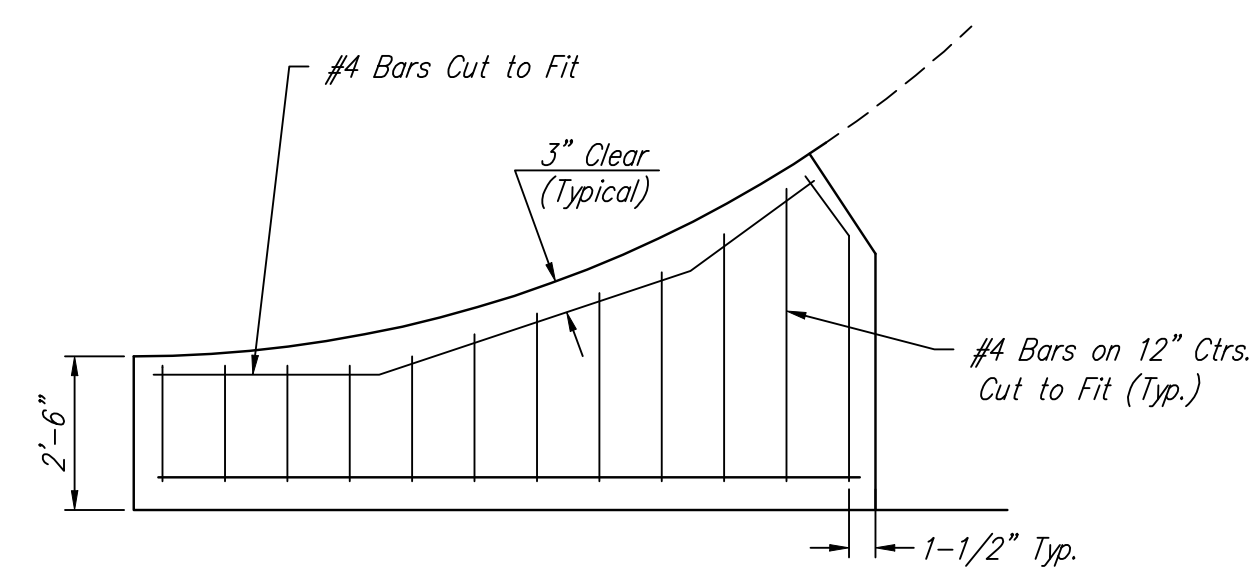

WING REINFORCING DETAIL

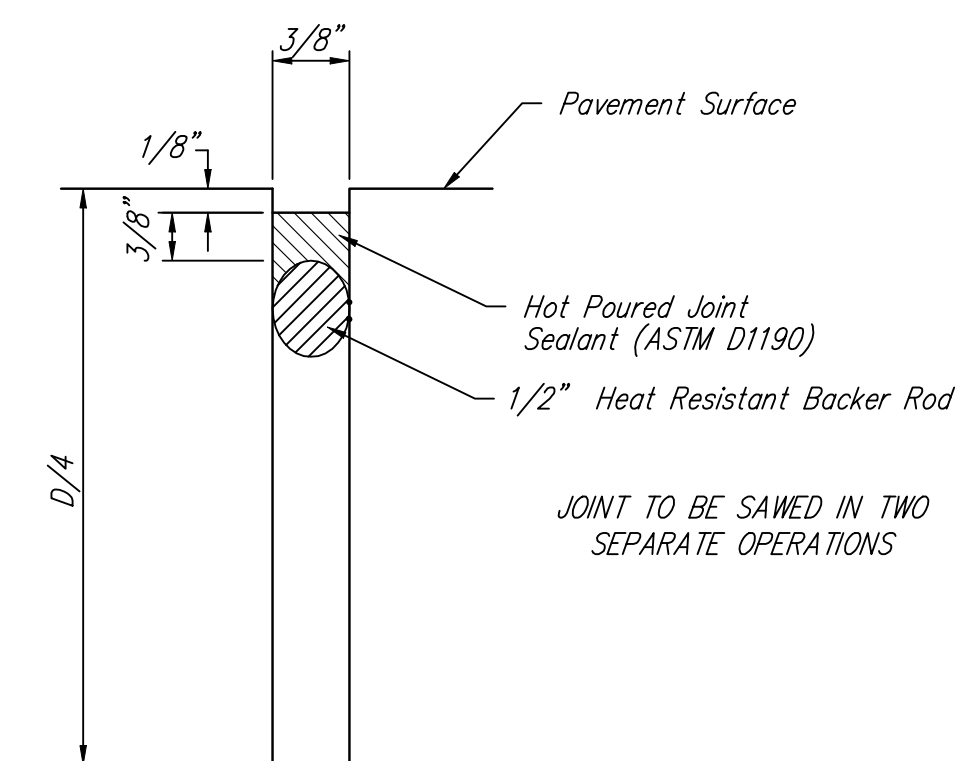

SAW JOINT DETAIL "B"

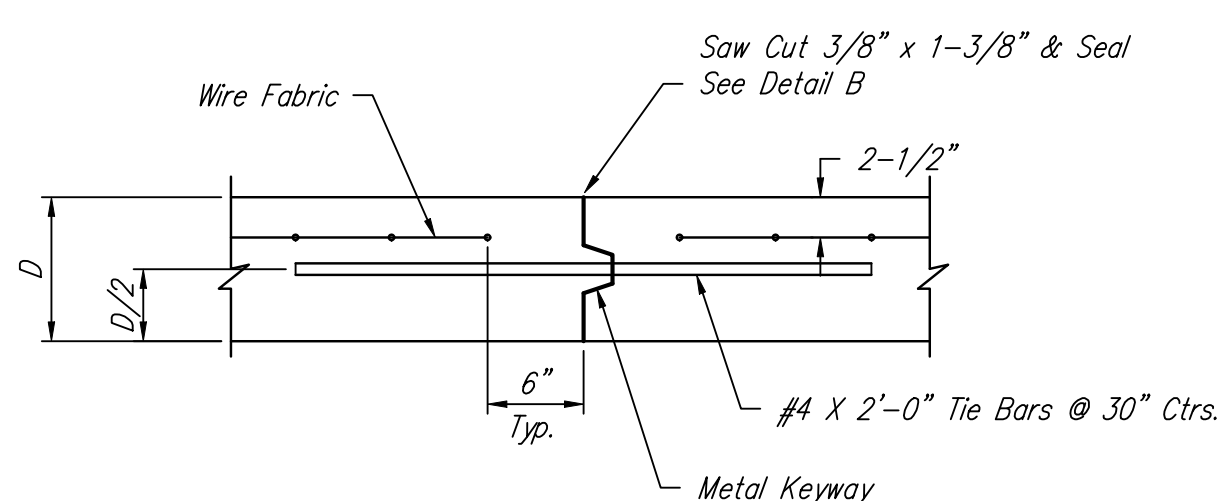

OPTIONAL LONGITUDINAL JOINT DETAIL (L.J.) (CONSTRUCTION JOINT)

NOTE: 6" X 12" W4XW4 Wire Fabric Reinforcing Shall Be Placed So That The Wires With The 6" Spacing Will Run Parallel With The Longitudinal Joints.

		VALLEY GUTTER DETAILS	
		Baughman Company, P.A. 315 Ellis St. Wichita, KS 67211 P 316-262-7271 F 316-262-0149 ENGINEERING SURVEYING PLANNING LANDSCAPE ARCHITECTURE	
PROJECT NUMBER	DESIGN STAFF	DRAWN STAFF	
REVISIONS:	APPROVED	DATE	
	SCALE	NONE	
	SHEET	4 OF 14	