

Note: Service Saddles are not required on top of 200 mains or larger

Meter boxes will be located on each lot to be served, as indicated in the SPECIAL PROVISIONS

### TYPICAL METER SETTING LONG SERVICE 25

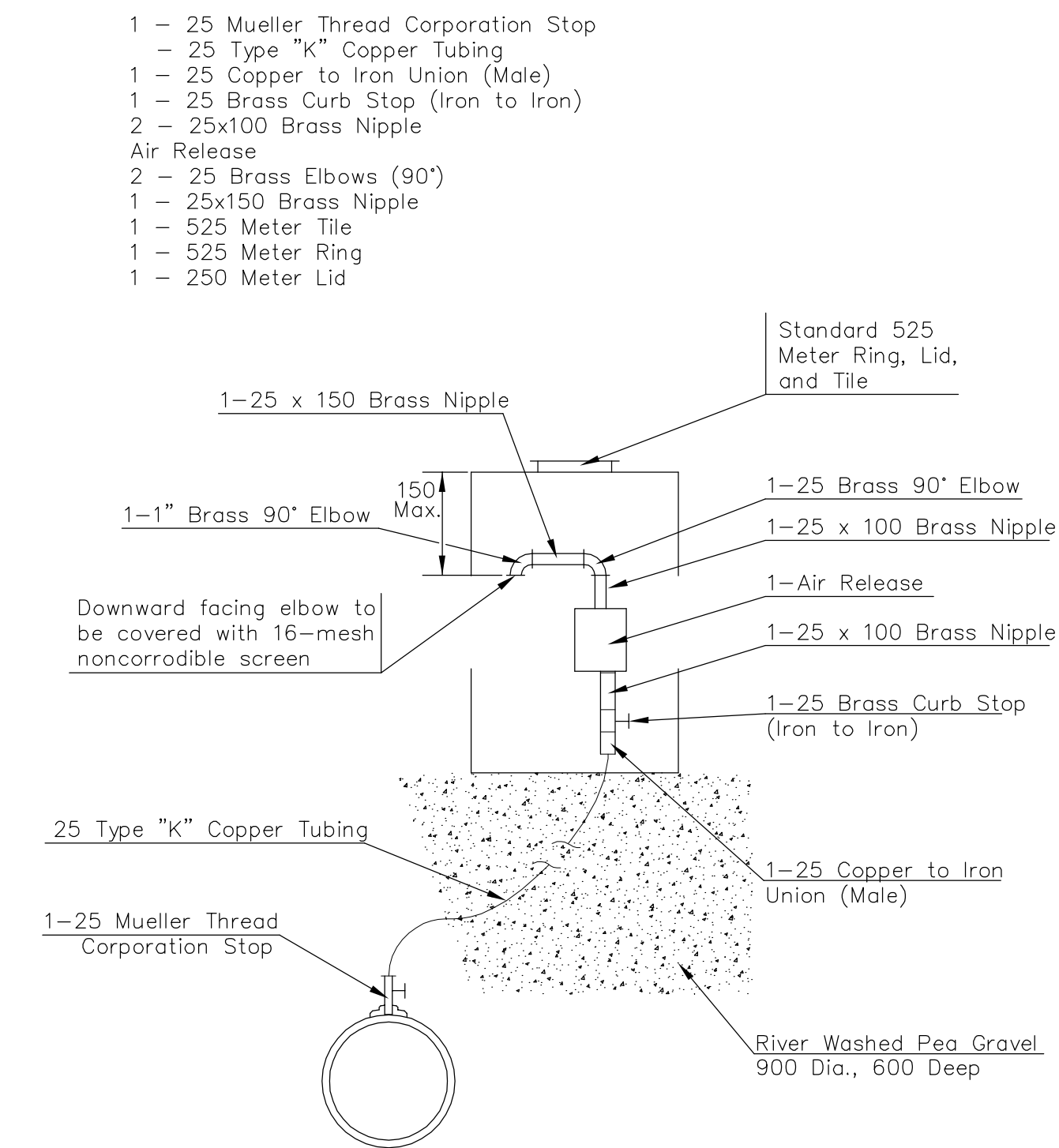

### MATERIALS FOR AIR RELEASE ASSEMBLY

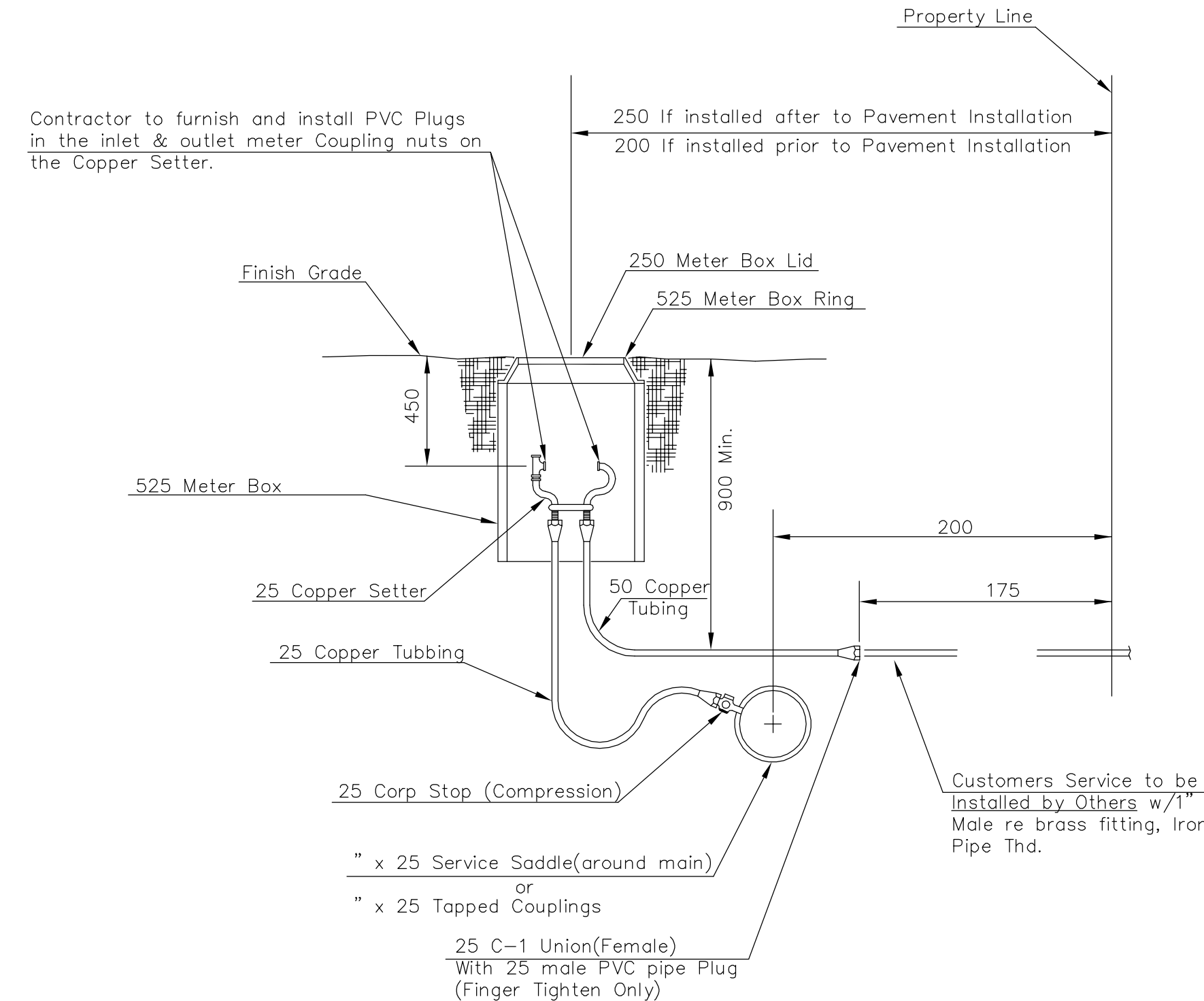

Note: Service Saddles are not required on top of 200 mains or larger

Meter boxes will be located on each lot to be served, as indicated in the SPECIAL PROVISIONS

### TYPICAL METER SETTING SHORT SERVICE 25

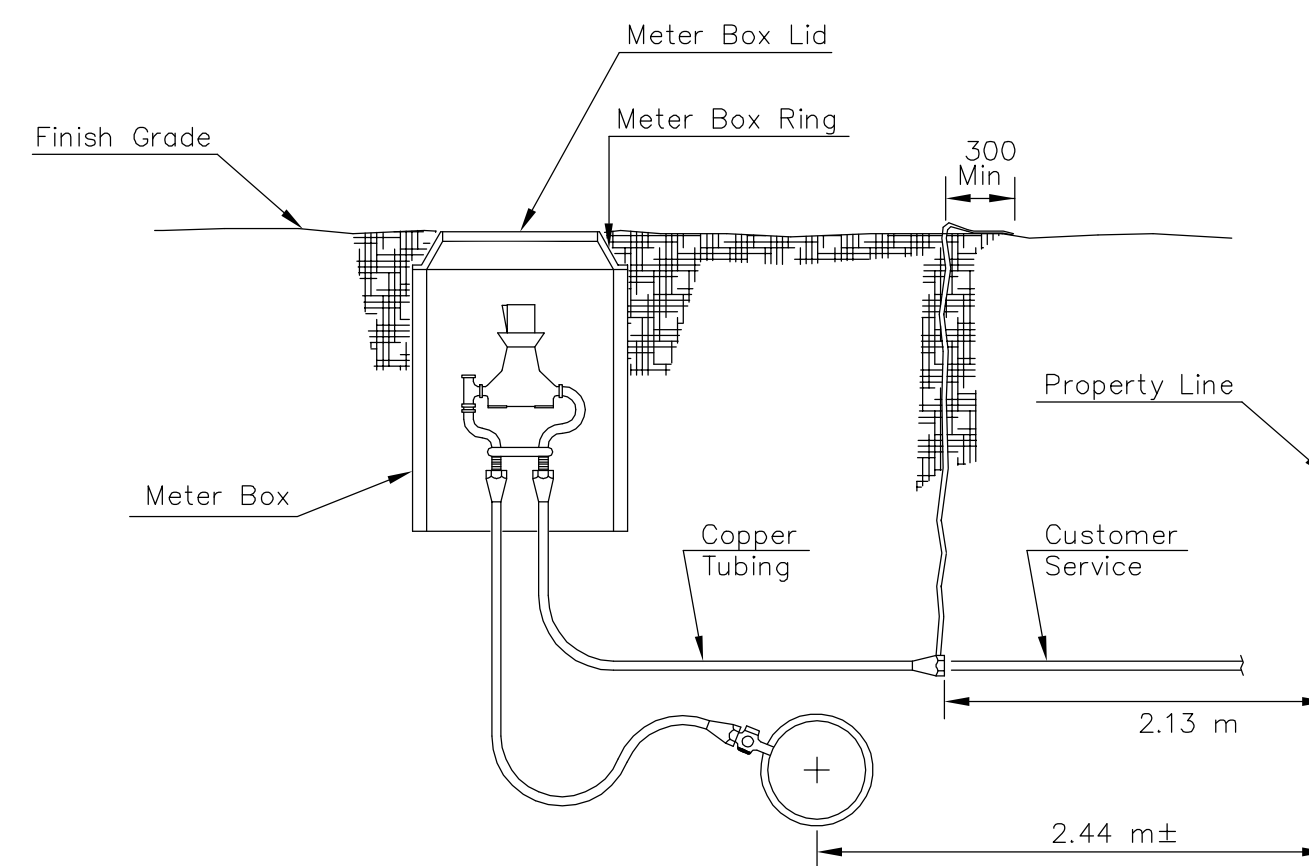

If customers service line is not installed at the time Meter Box and Setter are installed, Plastic Flagging is to be tied to the end of copper tubing & brought straight up to top of ground and be exposed a minimum of 300 on top of ground. (Plastic Flagging to be Furnished by Contractor)

### TYPICAL METER SETTING PLASTIC FLAGGING

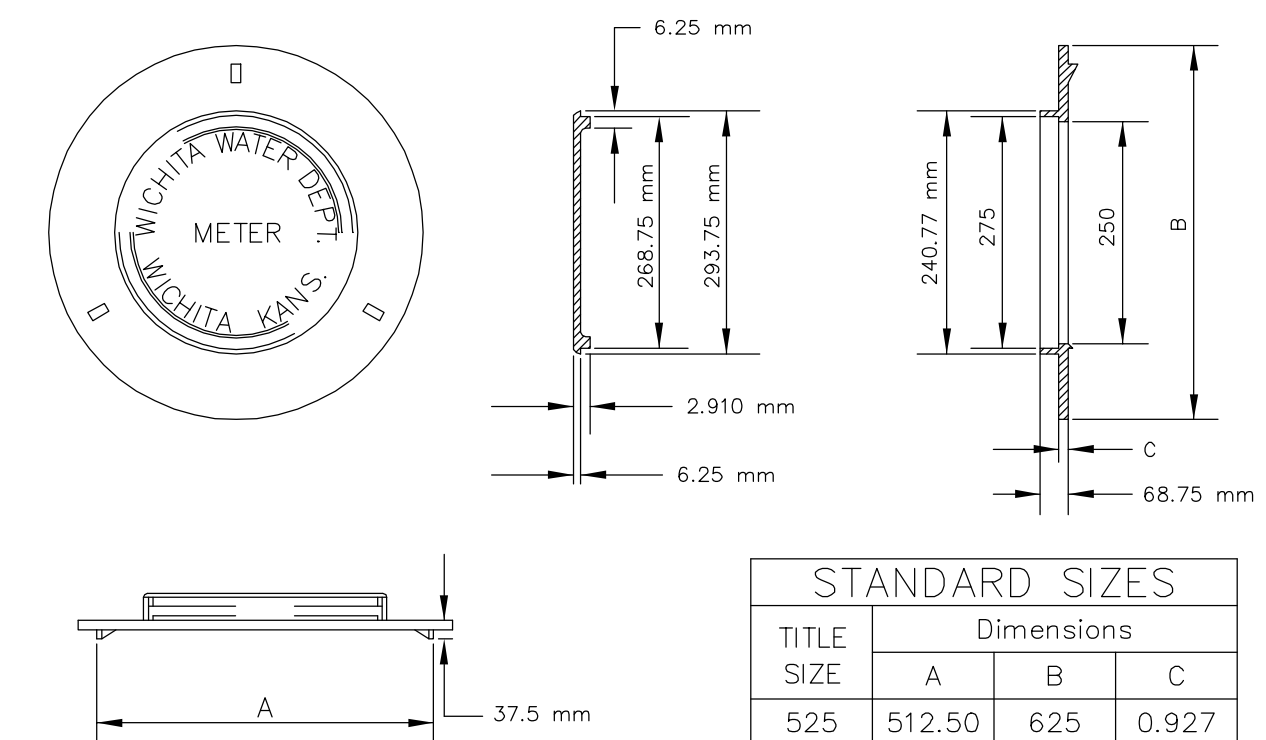

Other Approved Ring And Lids: Ford Meter Box Co. Inc. 525 Ring & Lid Catalog No. C-4

### RING & LID FOR METER VAULTS

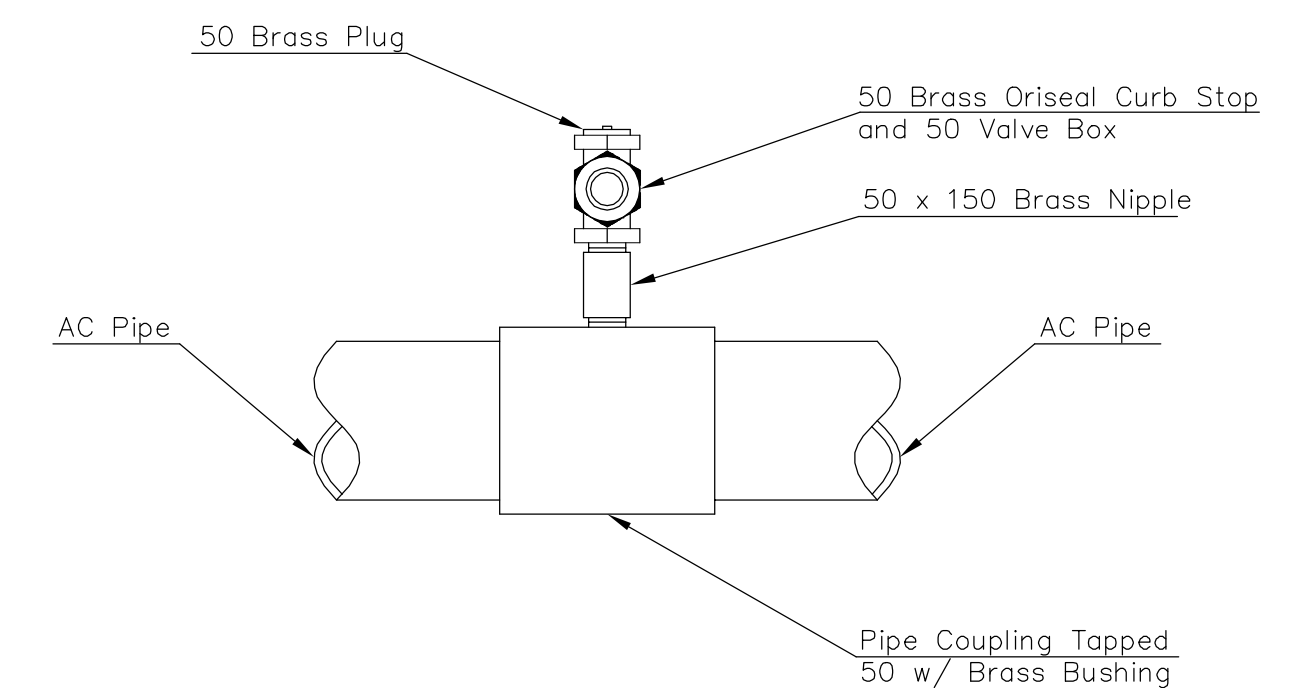

Note: Where the 50 service outlet assembly is to be used to connect a 50 main to another main, the 50 valve shall be a 50 IPT Gate Valve. 50 Ball or Globe valve shall not be approved for this use.

### 50 SERVICE OUTLET ASSEMBLY

<p>THE CITY OF WICHITA</p> <p>CITY ENGINEER'S OFFICE CITY HALL - SEVENTH FLOOR 425 NORTH MAIN STREET WICHITA, KANSAS 67202 (316) 268-4501 (316) 268-4114 FAX</p>	<b>STANDARD WATER SERVICE DETAILS</b>	
	M. E. LINDEBAK P.E. - CITY ENGINEER	
	PROJECT NUMBER 54-87 K-8258-06	INDEX CODE 7
	DATE 2004	SHEET 33 OF 71

REVISED APR 97