

STATE	PROJECT NO.	YEAR	SHEET NO.	TOTAL SHEETS
KANSAS	54-87 K-8258-02	2003	25	76

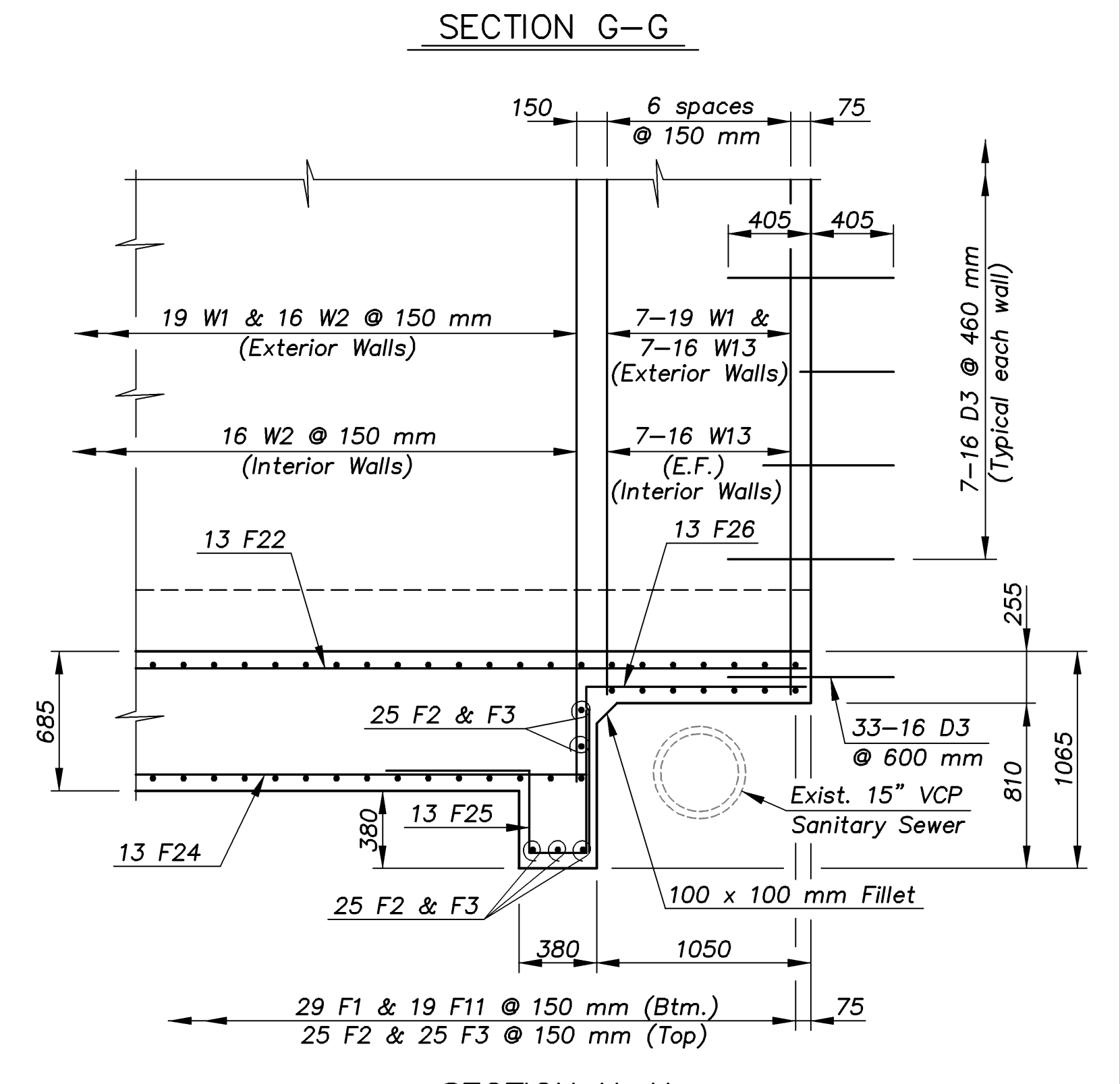
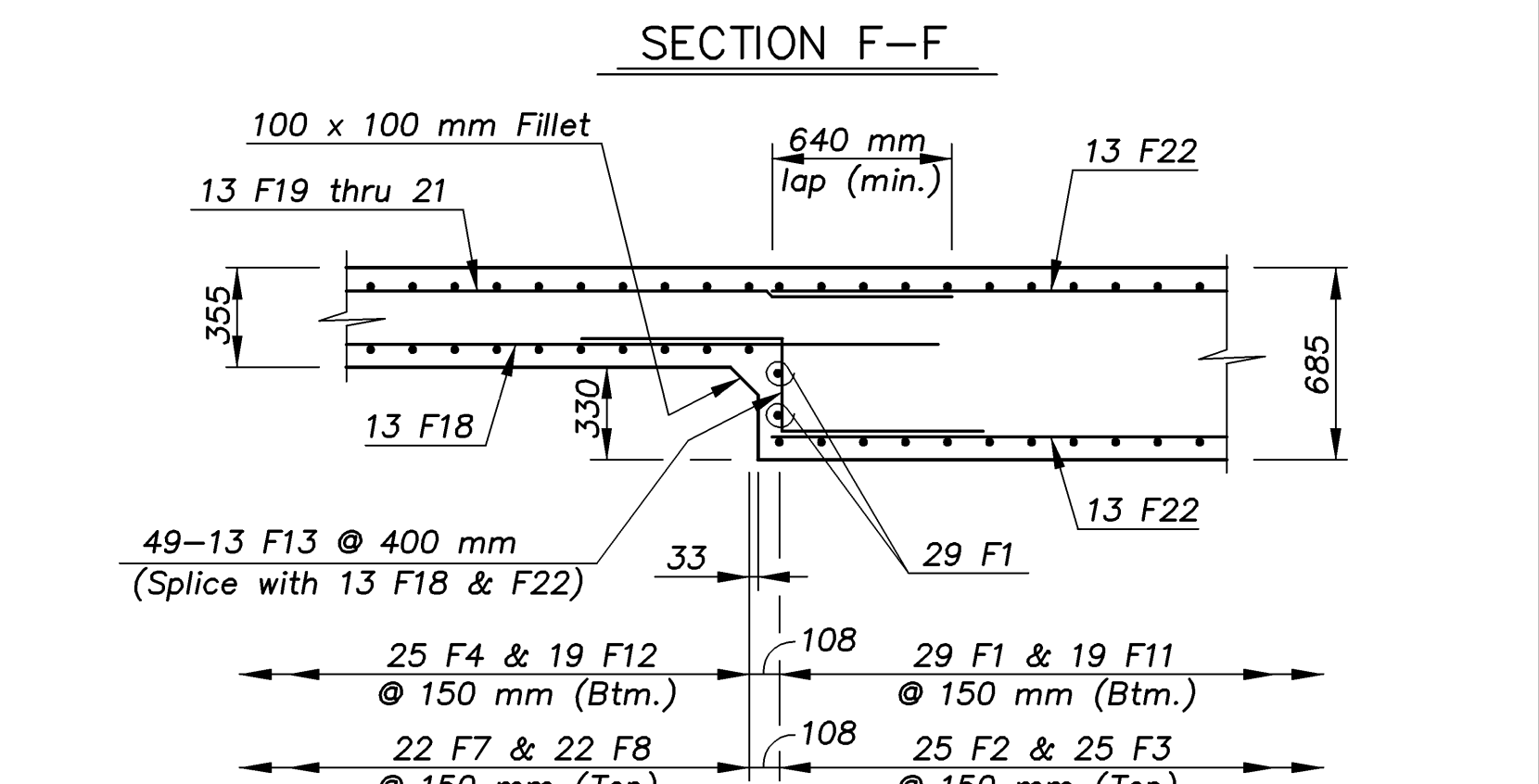
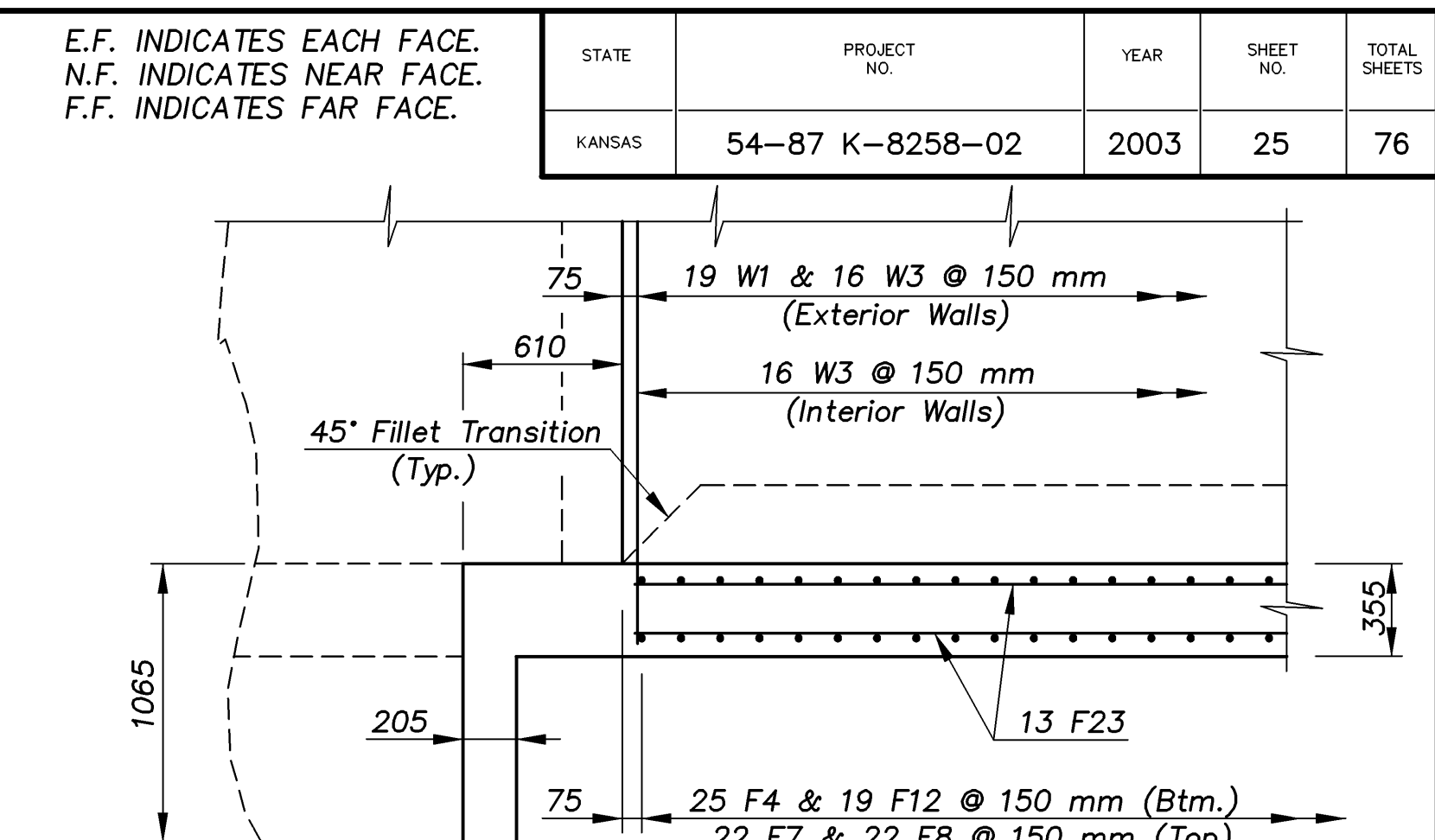
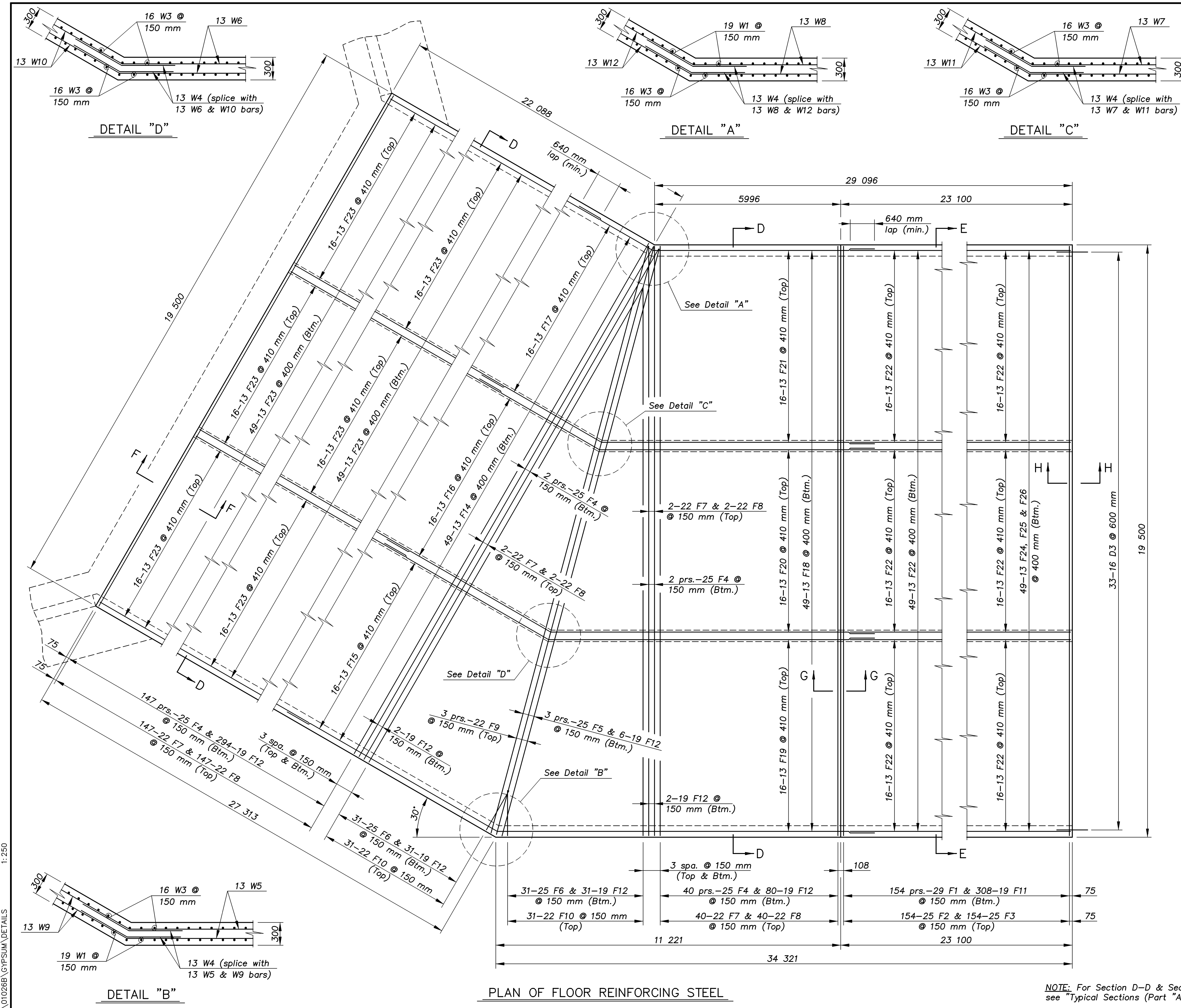

KANSAS DEPARTMENT OF TRANSPORTATION
 BR. NO. 54-87-31.63(706) STA. 4+689.738

TRIPLE 6.1 x 3.7 m R.C.B. FLOOR DETAILS (Part "A")

DESIGNED R.S.C. SCALE Varies
 DETAILED T.R.G. DATE
 QUANTITIES T.R.G. SHEET 4 OF 13

Cook, Flatt & Strobel ENGINEERS, P.A.

NOTE: For Section D-D & Section E-E see "Typical Sections (Part "A")" sheet.

J:\01026B\GYPSUM\DETAILS 1:250