

STATE	PROJECT NO.	YEAR	SHEET NO.	TOTAL SHEETS
KANSAS	54-87 K-8258-08	2005	40	223

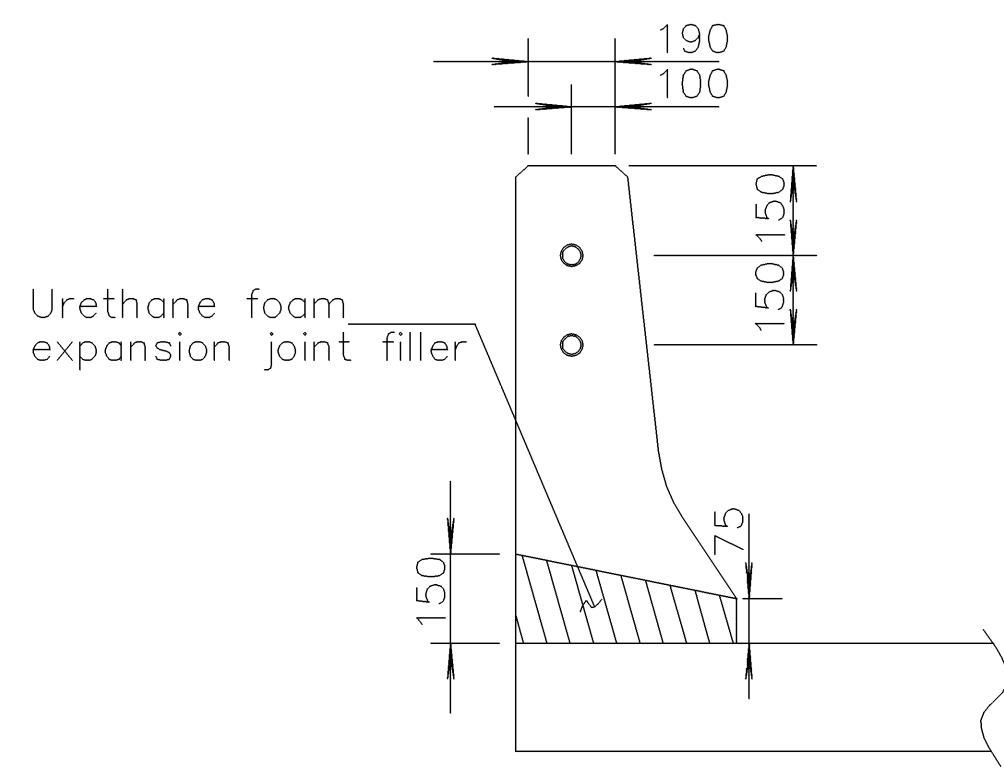

Note: Horizontal Reinforcement in Barrier shall not be continuous thru pressure relief joints.

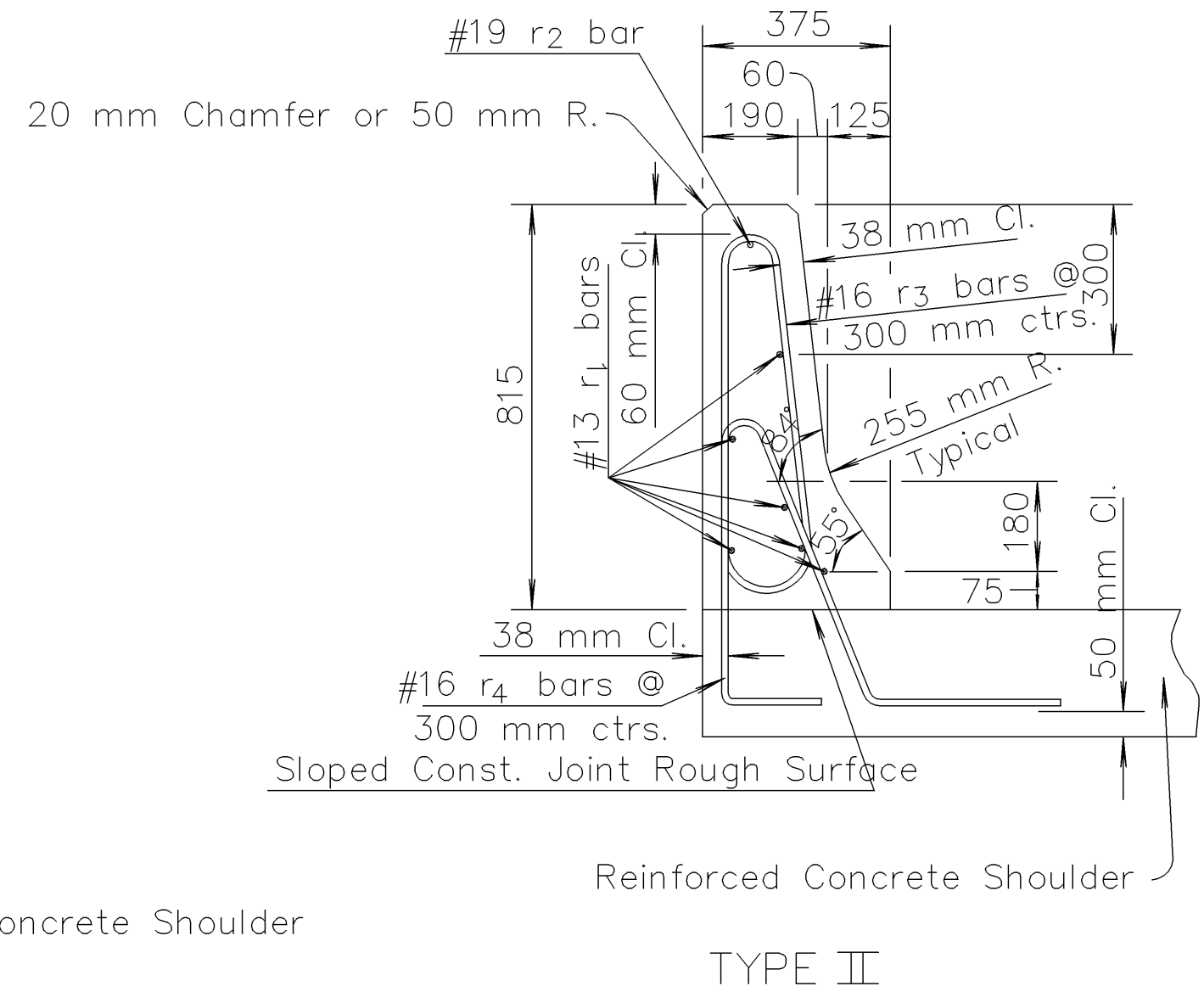
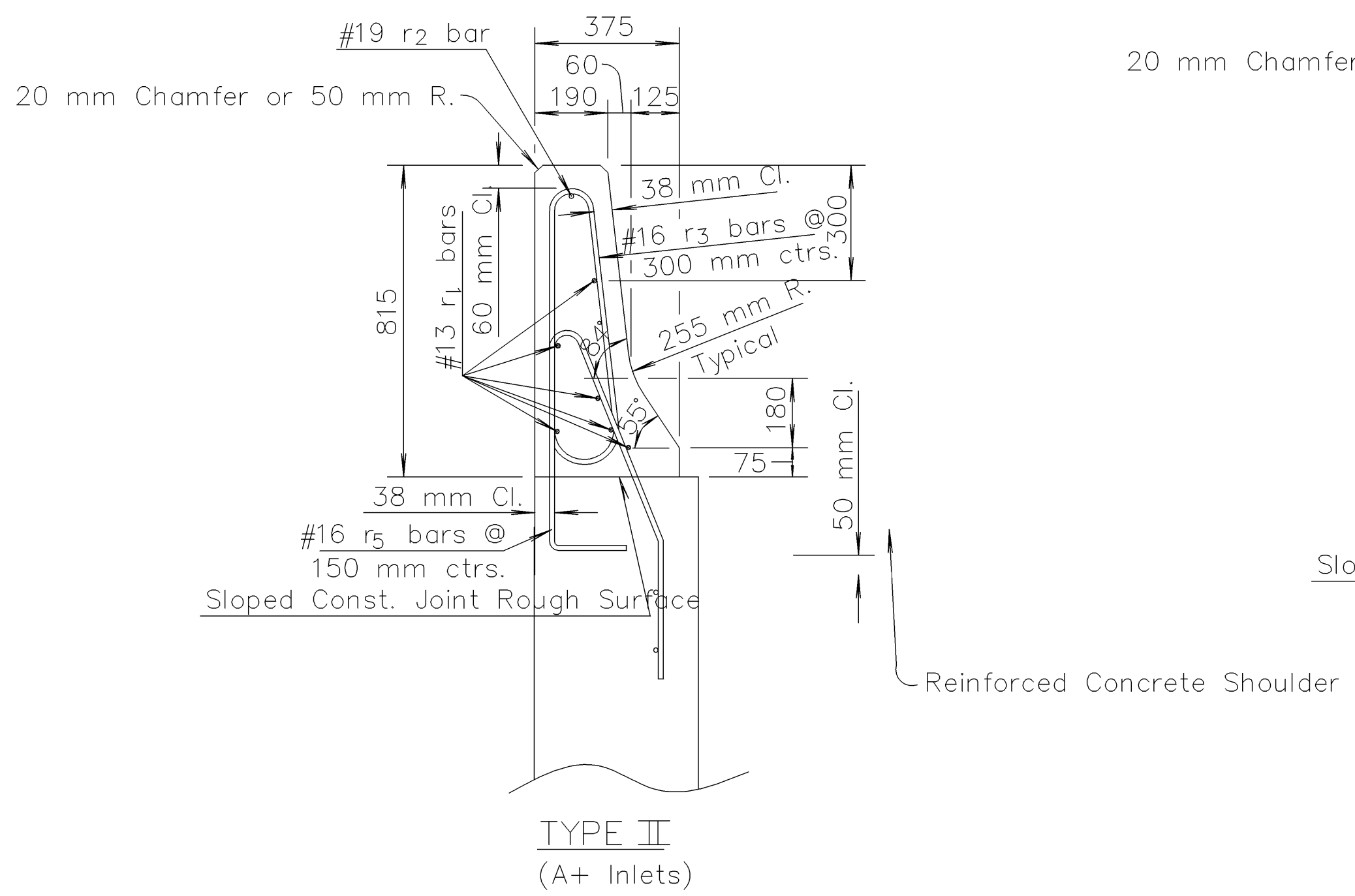

GENERAL NOTE
 Use either Grade 31 Concrete (AE) or the mix used in the concrete pavement for the barrier.
 Bars designated by number, e.g., #25 bars, shall be deformed reinforcing bars in compliance with the requirements of ASTM A 615m, Grade 420. All reinforcing shall be epoxy coated in accordance with the specifications. All bar supports shall be epoxy coated.
 Payment for all bars, joint material, median barrier filler material, reflectors and supporting materials, associated work, etc., shall be subsidiary.
 The section furnished must generally comply with the dimensions shown.
 Requests for minor variations in section geometry may be submitted for review.
 Permanent Concrete barriers shall be cast in place or slip formed construction only. Precast barriers will not be permitted.

EXPANSION JOINTS
 Expansion joints shall be made of Expansion Joint Material (Nonextruding, Type B), 25 mm thick, and constructed where shown; to match expansion joints in concrete pavement; at structures; and at the end of each day's pour. Where pavement joints are greater than 38 mm in thickness, the joint may be left open with no joint material above the adjoining surface. Expansion joint material shall be recessed 6 mm from barrier surface.

CONTRACTION JOINTS
 Contraction joints may be either formed or sawed on 6 m centers maximum. Where barrier is placed on or adjacent to concrete pavement, joints shall be spaced to match contraction joints and definite transverse cracks in the pavement, not to exceed 12 m centers.

100 mm PRESSURE RELIEF JOINT
 Joint material shall be preformed urethane foam joint material installed with lubricant adhesive, cut to the shape shown. The joint shall be constructed to match the 100 mm pressure relief joint of the concrete pavement approach slabs. Approximately three-fifths of the length of each dowel bar shall be coated with a hard grease prior to installation. The cutting length of the dowel bars shall be done in such a manner to result in no appreciable deformation of the ends. Dowel bars shall be plain reinforcing bars in compliance with the requirements of ASTM A 615m, Grade 420. Dowel bars shall be epoxy coated in accordance with the specifications. All work and materials required for installation of joint material shall be subsidiary to Concrete Safety Barrier and shall conform to the Standard Specifications.

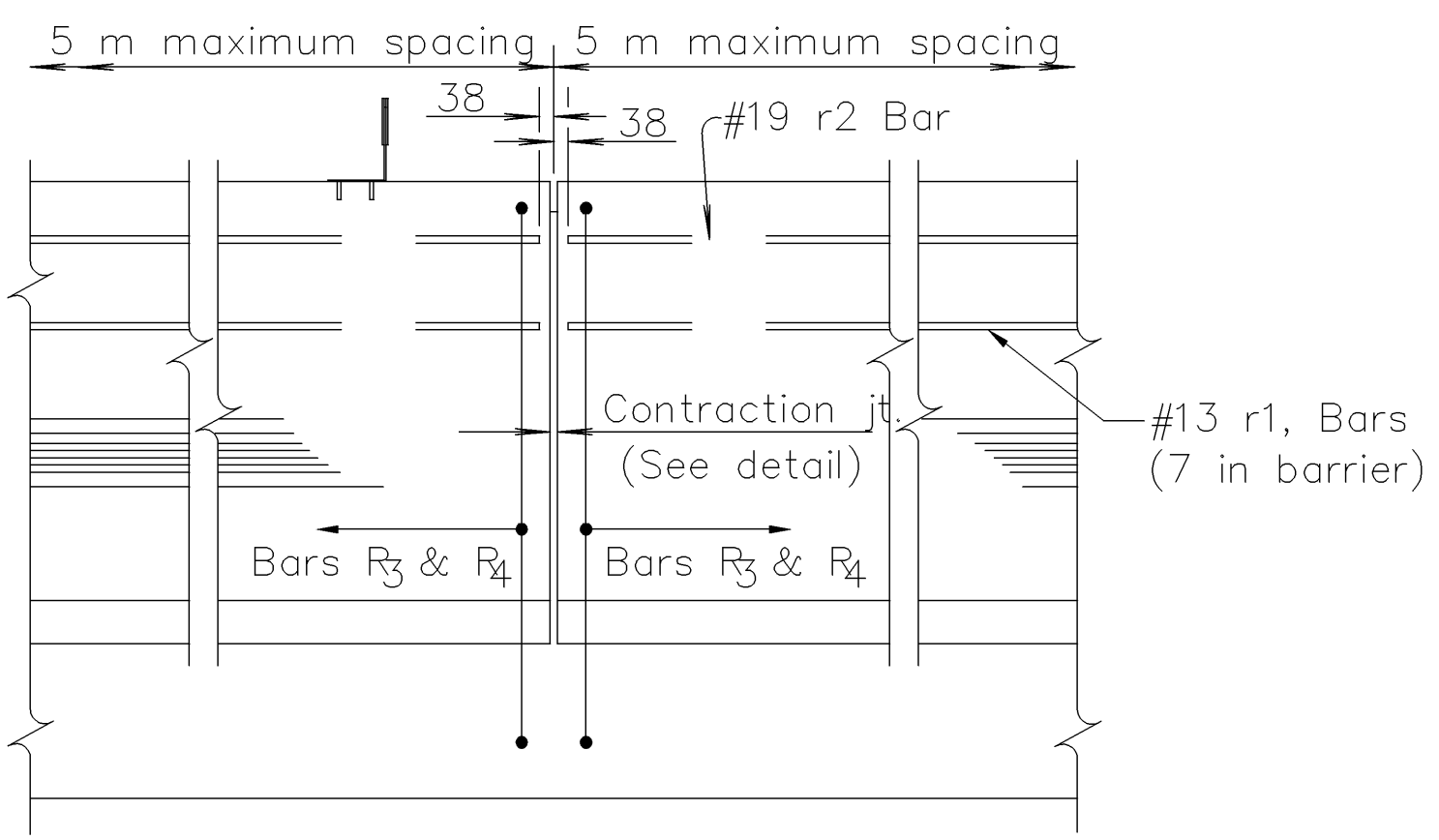

Contraction Joint Elevation
 Note: Horizontal Reinforcement in Barrier shall not be continuous thru contraction joints.

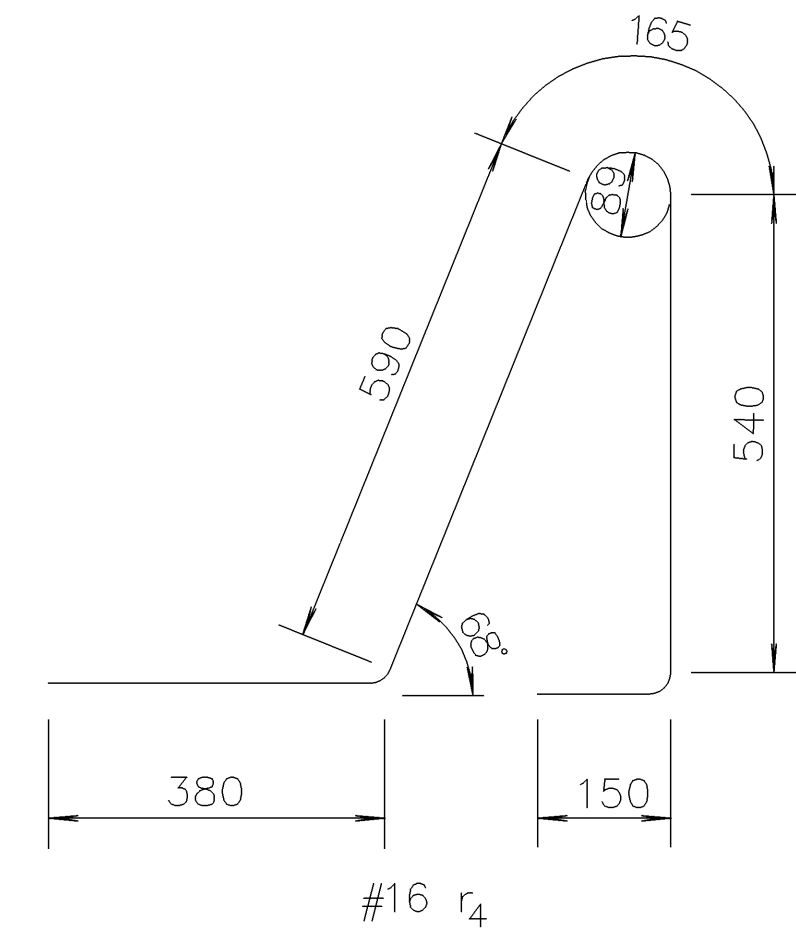
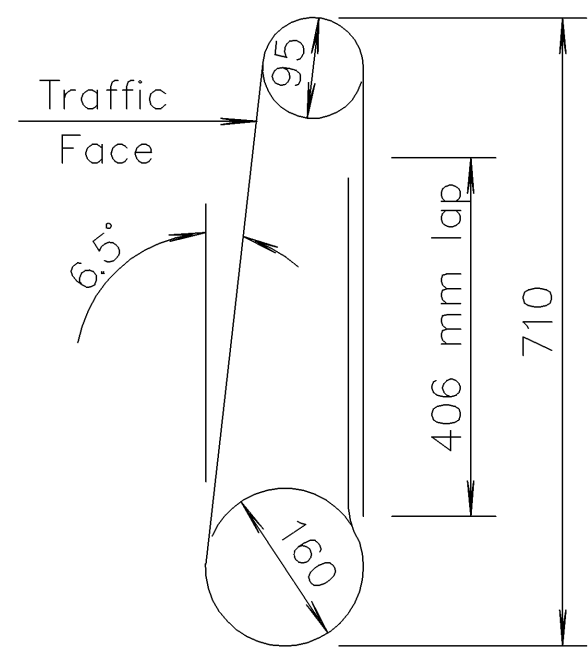

BENDING DIAGRAMS
 Note: All dimensions are out to out of bars.

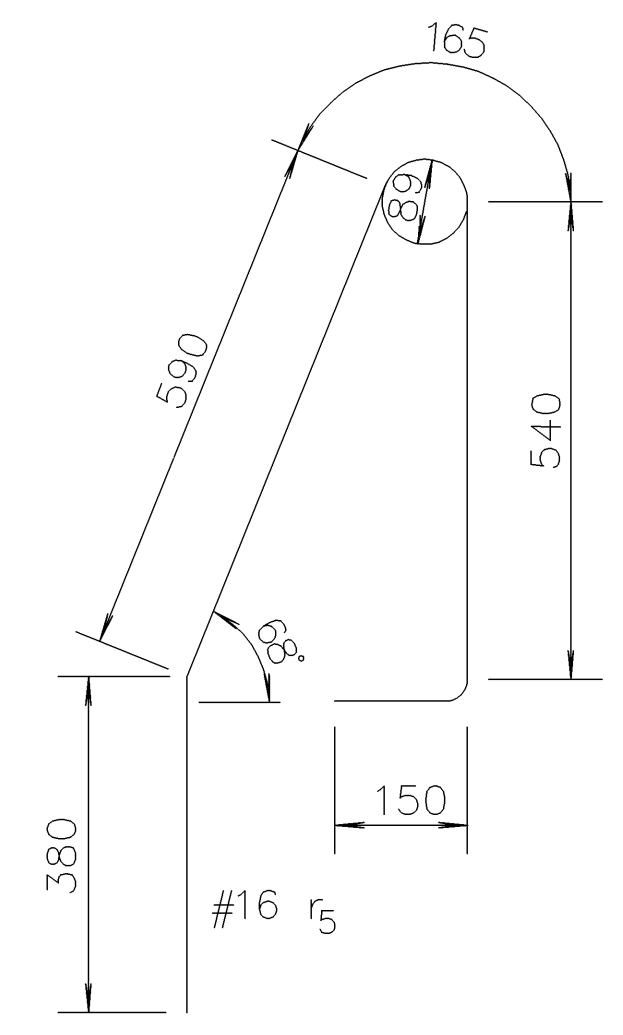

BENDING DIAGRAMS
 Note: All dimensions are out to out of bars.

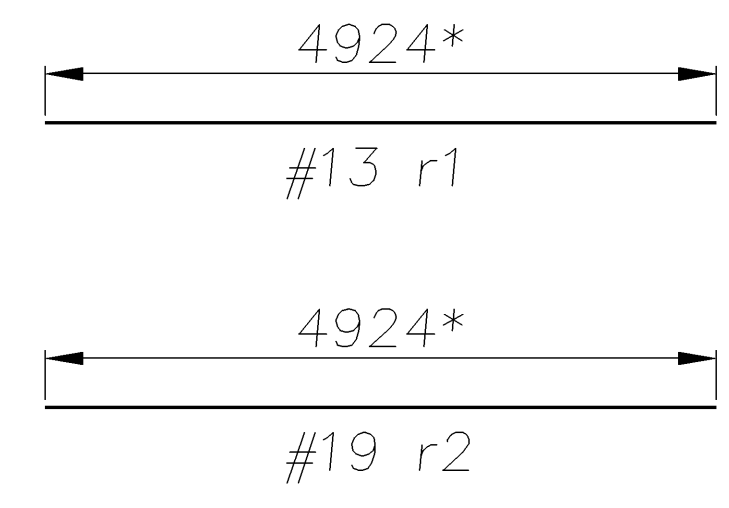

* Length is for a normal contraction joint spacing of 5 m. Where contraction joint spacing is less than 5 m, excess length of bar may be cut off. Touch up epoxy coating in accordance with the specifications.

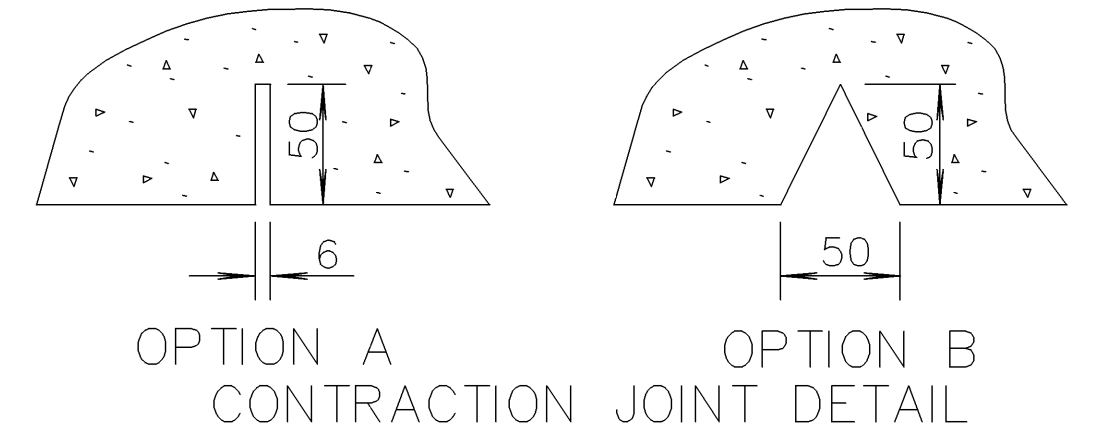
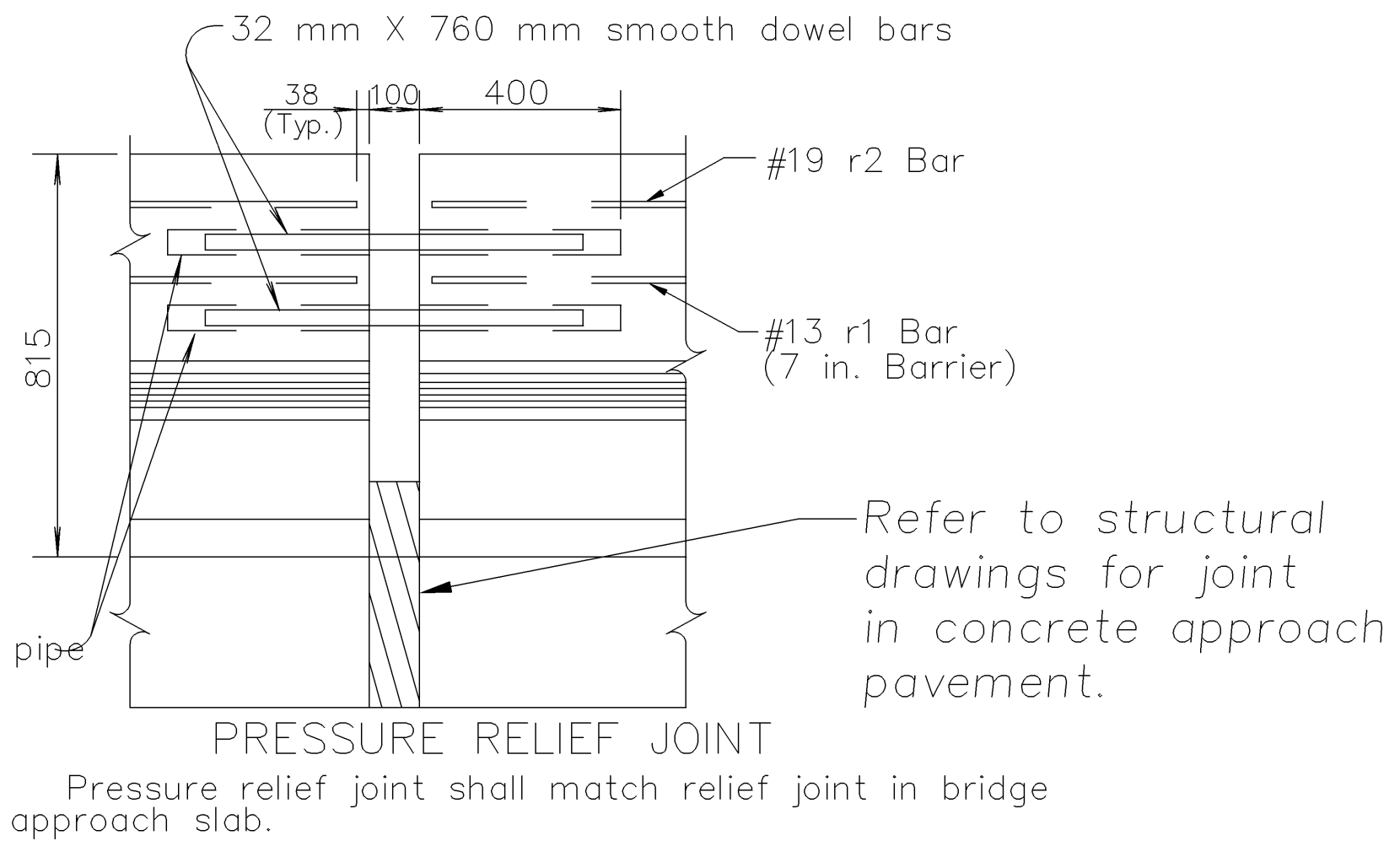

NO.	DATE	REVISIONS	BY	APP'D
3				
2	4-30-02	Rev. concrete from Class to Grade.	S.W.K.	J.O.B.
1	12-12-00	Revised bending diagram	R.J.S.	J.O.B.

KANSAS DEPARTMENT OF TRANSPORTATION
PERMANENT CONCRETE SAFETY BARRIER
TYPE I, II, III & IV (F-SHAPE)
 RD632-SI

FHWA APPROVAL	5-01-02	APP'D	James O. Brewer
DESIGNED		QUANTITIES	TRACED Bowser
DESIGN CK.	DETAIL CK.	QUAN. CK.	TRACE CK. Seitz

Drawn By: USERNAME Plotted: \$\$\$\$\$\$SYTIME\$\$\$\$\$\$
 File: \$\$\$\$\$\$DGN\$SPEC\$\$\$\$\$\$