

E.F. INDICATES EACH FACE.  
 N.F. INDICATES NEAR FACE.  
 F.F. INDICATES FAR FACE.

STATE	PROJECT NO.	YEAR	SHEET NO.	TOTAL SHEETS
KANSAS	54-87 K-8258-08	2005	109	223

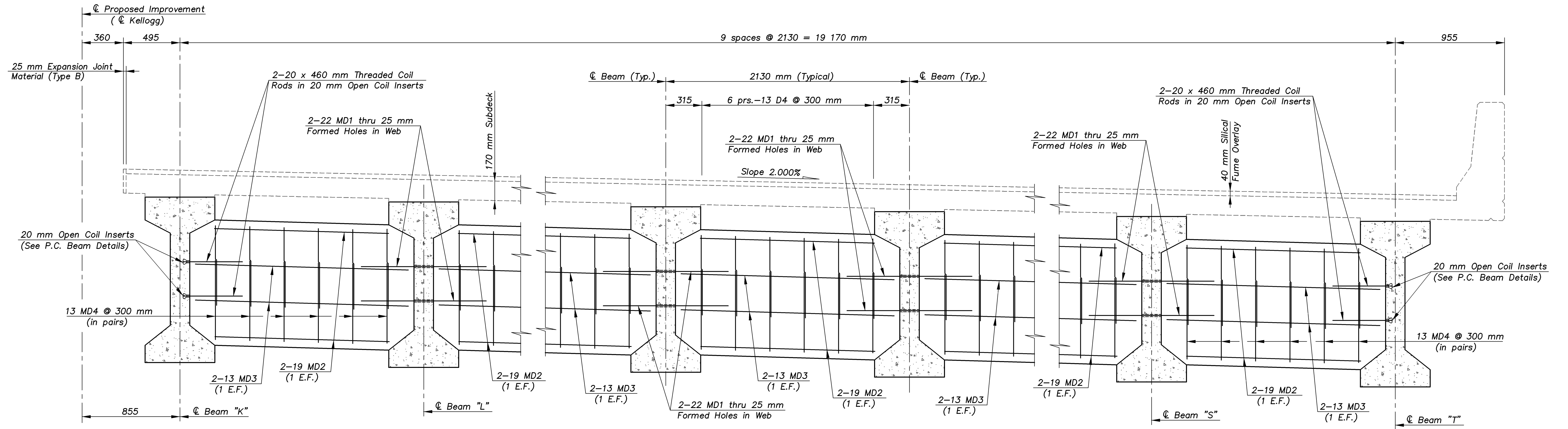

PARTIAL ELEVATION SHOWING DIAPHRAGM AT MID-SPAN  
 (Center Span Only)

**NOTE:** Cure all Mid-Span Diaphragms a minimum of 7 days prior to placing any concrete in the bridge deck.

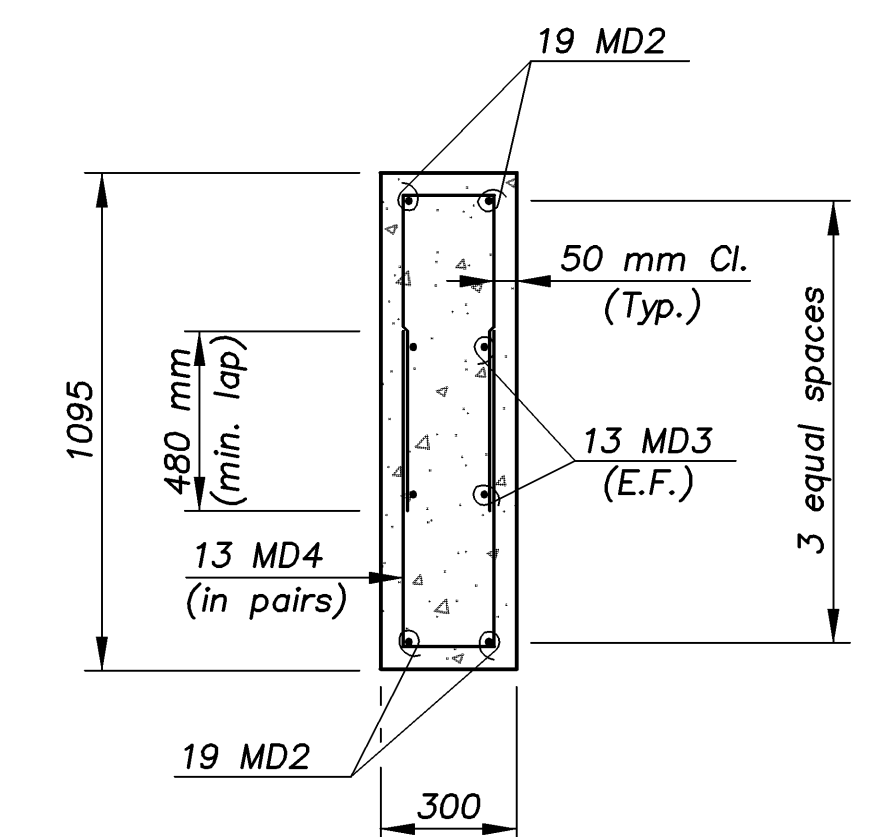

TYPICAL SECTION THRU DIAPHRAGM

EASTERN/DIAPHRAGMS 1:100

KANSAS DEPARTMENT OF TRANSPORTATION	
BR. NO. 54-87-31.56(705) E.B.	STA. 4+575.138
<b>MID-SPAN DIAPHRAGM DETAILS</b>	
KELLOGG AVENUE OVER EASTERN	
Proj. No. 54-87 K-8258-08	SEDGWICK COUNTY

<b>CFS</b>	
Cook, Flatt & Strobel ENGINEERS, P. A.	
DESIGNED R.S.C.	SCALE Varies
DETAILED T.R.G.	DATE
QUANTITIES T.R.G.	SHEET 31 OF 47