

SPECIFICATIONS: Standard Specifications for State Road and Bridge Construction as currently used by the Kansas Department of Transportation. The following items are covered in Division 700 of the Standard Specifications:

CONCRETE: Concrete for cast-in-place shall be $f'c = 20$ MPa. Concrete for prestressed shall be $f'c = 35$ MPa.

WELDING: All field welding shall meet the requirements of the Standard Specifications.

TEST PILES: Drive test piles where called for on the bridge plans. The test piles located within the limits of the substructure will become a part of the bridge pile system.

SPLICES: Splices for steel piles and shell piling shall be in accordance with details shown on this sheet and the Standard Specifications.

Fabricate prestressed concrete pile splices in accordance with the Manufacturer's recommendations subject to the approval of the Engineer.

DRIVING FORMULA: Driving formula shall conform to the Standard Specifications.

MEASUREMENT AND PAYMENT: Measurement and payment for all piles shall comply with the Standard Specifications.

The following items are covered in Division 1000 of the Standard Specifications:

REINFORCEMENT: Use reinforcing steel conforming to ASTM A615M-96, Grade 420. Hoops and spirals may be either plain or deformed bars.

PRESTRESSING STEEL: Use uncoated seven-wire stress relieved or low relaxation prestressing strand conforming to ASTM A416M, Gr. 1860.

CAST-IN-PLACE SHELLS: Steel shells for cast-in-place piles shall conform to the requirements of the Standard Specifications.

All piles driven without a mandrel shall be of the minimum thicknesses shown. Piles driven with a mandrel shall be of sufficient strength and thickness to withstand driving without injury and to resist harmful distortion and/or buckling due to soil pressure after the mandrel is removed.

Remove, replace or correct to the satisfaction of the Engineer improperly driven, broken or otherwise defective pipe piles. Otherwise drive an additional pile at no extra cost.

The Contractor shall maintain a light suitable for visual inspection of the pile on the job at all times prior to and during the filling of the pipe.

STEEL PILE: Steel pile shall conform to the requirements of the Standard Specifications.

PILE POINTS: Pile points shall conform to the dimensions shown and to requirements of the Standard Specifications.

PAINT: All paint shall comply with the Standard Specifications, or as specified on the plans.

MILL TEST REPORTS: Steel piles test reports and steel shell test reports shall comply with the Standard Specifications.

O D 275 T. = 6 mm
O D 325 T. = 6 mm Min.
O D 355 T. = 6 mm Min.

Note:
Pile shall be driven with a steel head having a projecting ring fitting inside the pipe. Clearance between ring and pipe should be 5 mm.

PIPE PILE SPLICE DETAIL

Note:
Pile pipe may be spiral welded, longitudinal welded, or seamless steel pipe.

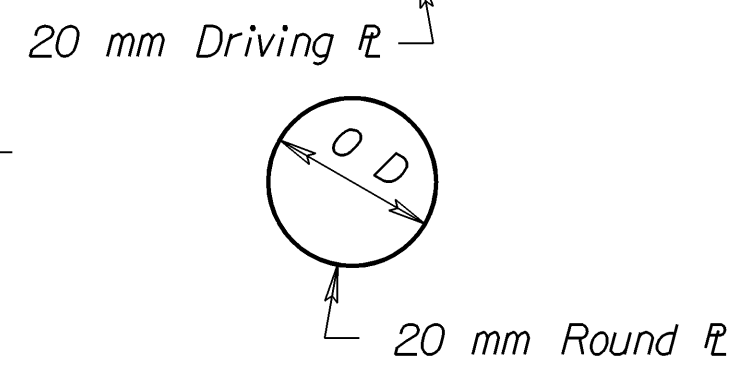

PLAIN ROUND CAST-IN-PLACE CONCRETE PILES

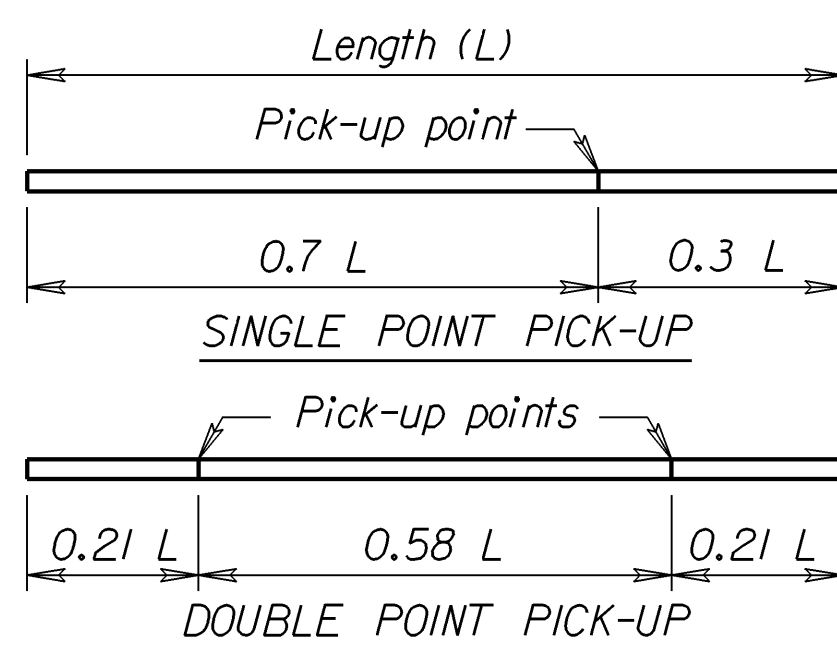

PICK-UP POINTS FOR PRESTRESSED PILING

Max. length - 16 m single point pick-up
Max. length - 24 m double point pick-up

Note: Mark piles at pick-up points to indicate proper points for attaching handling lines.

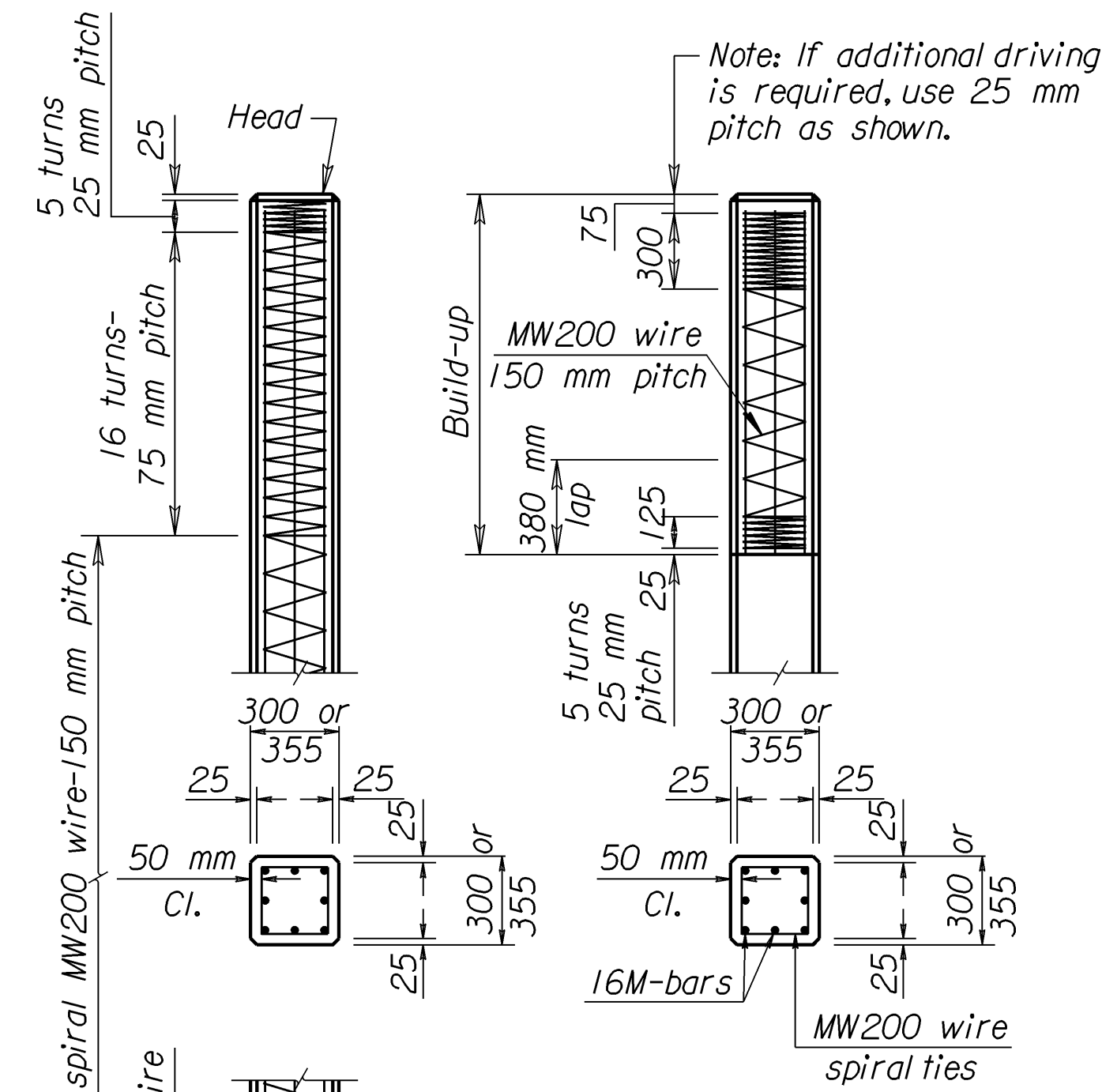

300 mm OR 355 mm PRESTRESSED CONCRETE PILES

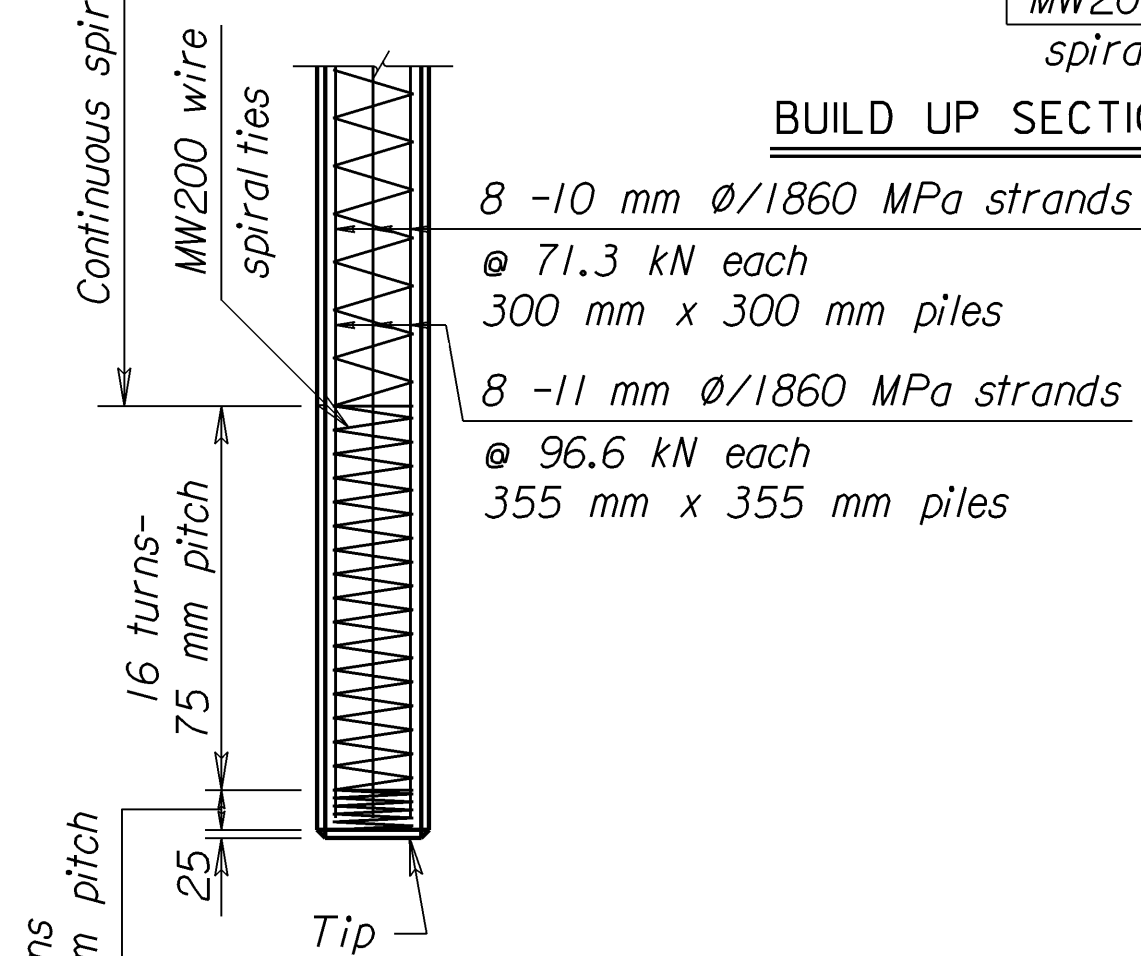

410 mm PRESTRESSED CONCRETE PILES

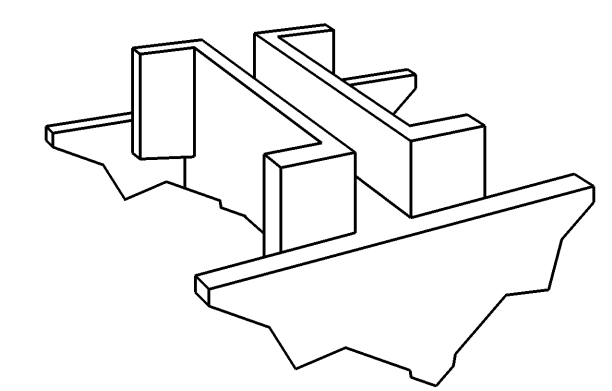

CAST STEEL PILE POINT

The pile point shall be a one-piece unit of cast steel. Weld pile points in accordance with manufacturer's recommendations to each steel pile before driving.

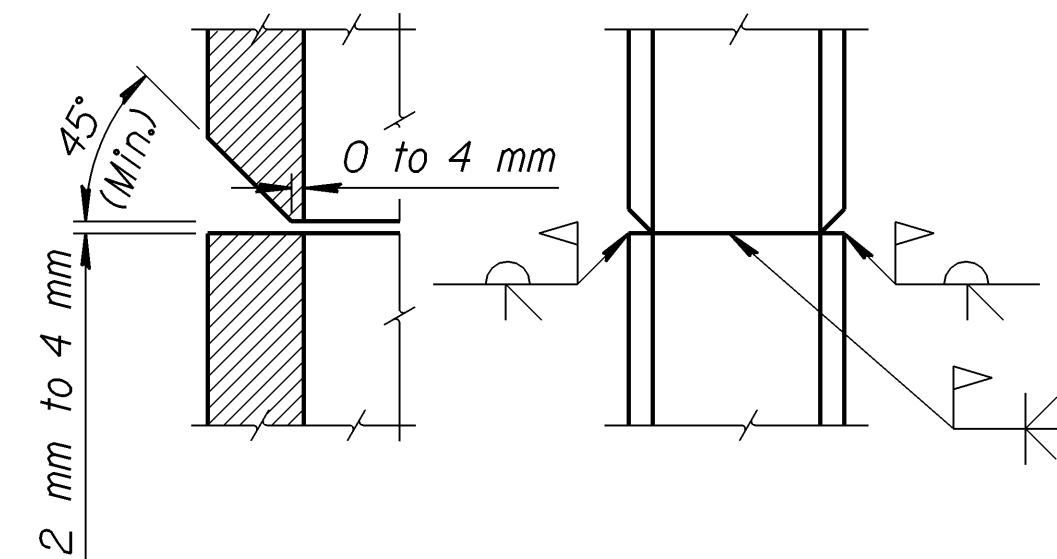

SECTION THRU FLANGE

PILE SPLICE DETAIL (H-PILE)

PRESTRESSED PILES

Method of attachment of pile to build-up may be by any of the methods given in the notes on "Alternate Methods. If mild reinforcing steel is used for attachment, the area shall be no less than that used in the build-up.

ALTERNATE METHODS:

- Method of attachment of a pile to build-up may be by any of the following methods:
1. Cut off at least 600 mm of pile and expose a minimum of 600 mm of strands.
 2. Cast 8-19M bars (equally spaced) into pile head. All bars shall extend into pile head and project from pile head a minimum of 600 mm.
 3. Drill 8 holes in pile head (equally spaced) for installation of 8 grouted dowel bars of same size and length as in 2.
 4. Provide cored holes for bars as in 3.

If a pile splice is required on pile bents, locate the joint at least 4.5 m below finished ground line after driving.

No bars or strands are to extend from head of pile or build-up into footing or pile cap unless approved by the Engineer.

FOR INFORMATION ONLY EQUIVALENT POINT BEARING PILES

STEEL PILES	CONCRETE PILES	
	Pipe	Pre-stress
250x62	275	
310x79	325	
360x108	355	300
360x152		355
360x174		410

NO.	DATE	REVISIONS	BY	APP'D
3	6-23-97	Change resteelgrade	LRR	KFH
2	3-27-96	ASTM A615M-96 Changes	LRR	KFH
1	6-30-95	Correct spiral wire size	LRR	KFH

KANSAS DEPARTMENT OF TRANSPORTATION

STANDARD PILE DETAILS

BRIIO SI		7-9-97 APP'D	
DESIGNED	DETAILD	QUANTITIES	CADD
DESIGN CK.	DETAIL CK.	LRR QUAN.CK.	CADD CK.

Std. Base File : /usr2/stand/si/br/10si.dgn
Working File :
Back Up File : View: PLOT1

Plotted By : unfiled
Plot File : J:\0001\PHI\standards\BRIIO\0si.dgn
Plot Date : 6/17/2005