

DETECTOR SUMMARY						
DETECTOR NO.	MODE	SIZE LxW	PHASE CALLED	PHASE EXTENDED	DELAY/STRETCH TIMER	INITIAL SETTING (SEC.) DWELL
1	Presence	15 x 1.8	2	6		
2 & 3	Pulse	4 x 1.8	3	5		

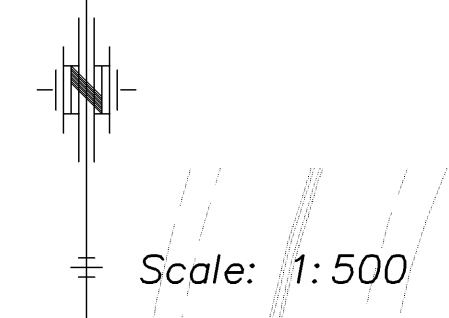

BY	DATE
REFERENCE NOTED	REFERENCE CHECKED

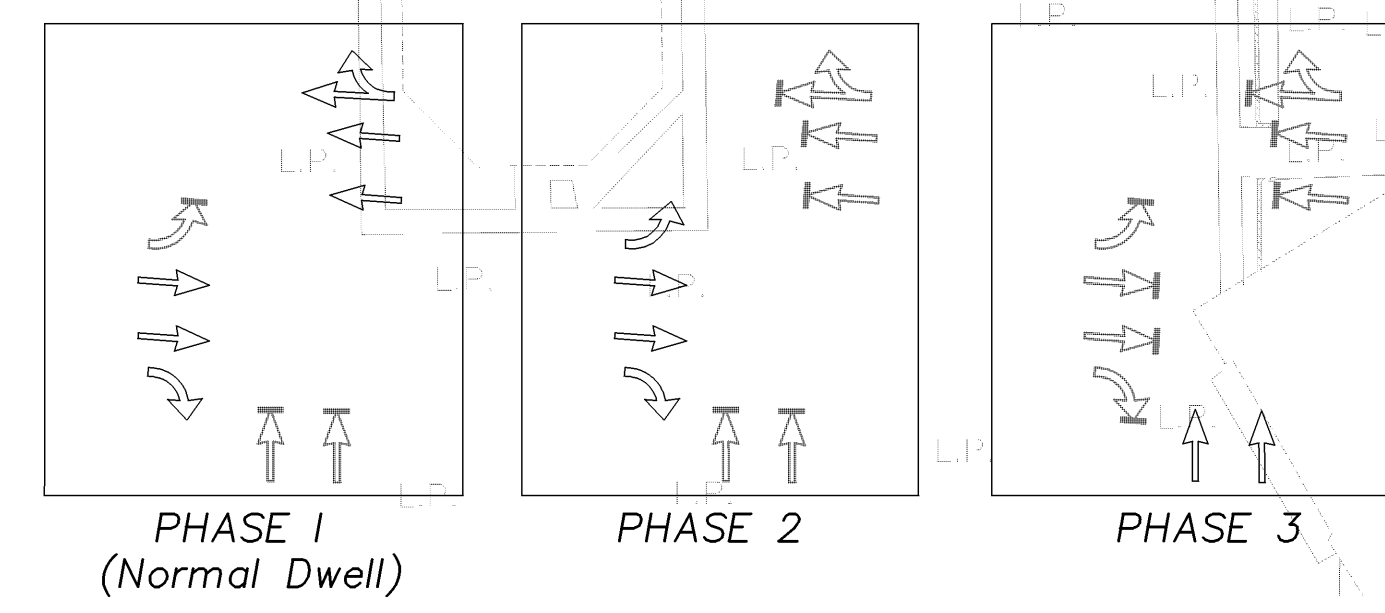
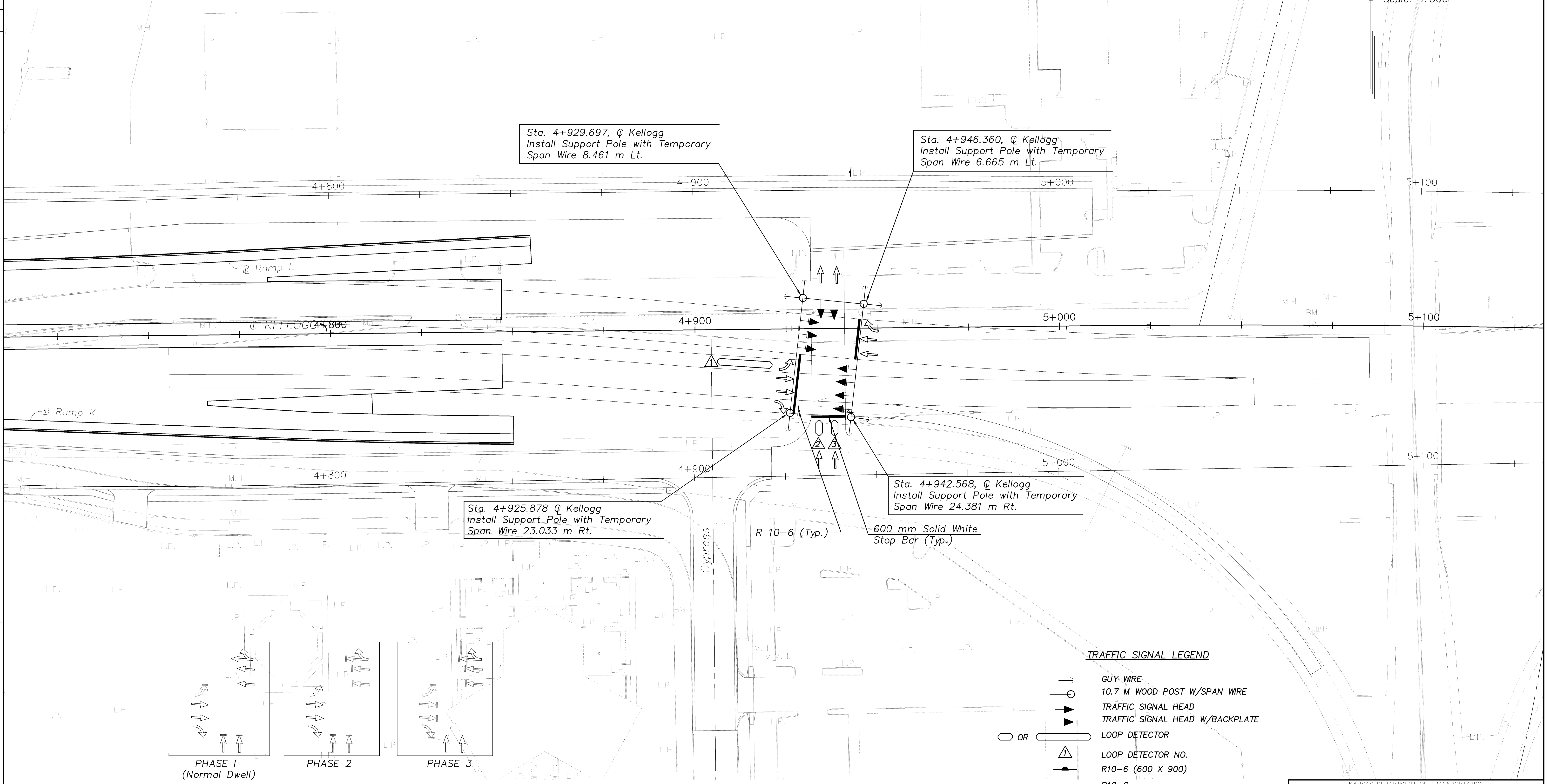

PHASE DIAGRAM

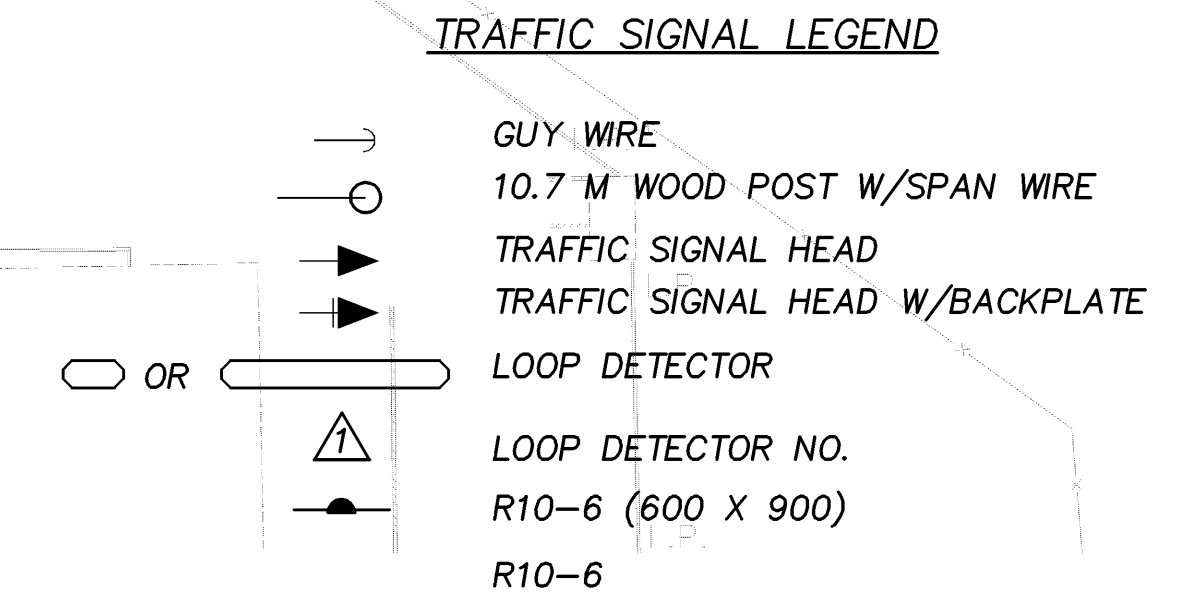

NOTE:
 PLAN LOCATION IS FOR GENERAL LOCATION AND CONTRACTOR
 MUST ADJUST THE LOCATION AS REQUIRED BASED ON ACTUAL
 GEOMETRICS OF TURNAROUNDS CONSTRUCTED.

**STOP
 HERE ON
 RED**

KANSAS DEPARTMENT OF TRANSPORTATION

**EAST KELLOGG
 STA. 4+725 TO STA. 5+125**