

ASSEMBLED CONNECTION END VIEW

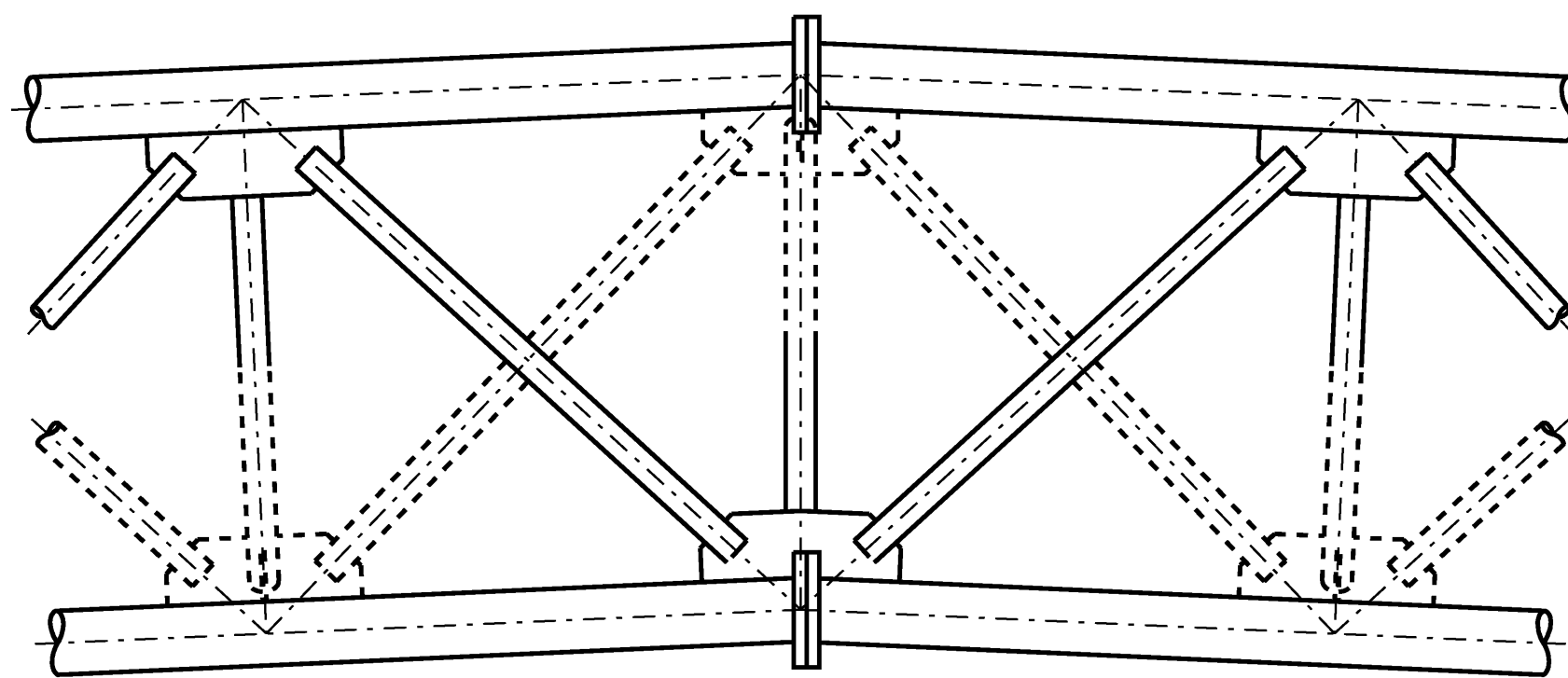

TYPICAL SPLICE  
(showing camber method type 2)

	PIPE COUPLING PHYSICAL CHARACTERISTICS						
	Pipe Diameter	Coupling Dim.		Coupling Bolts *		Rollers per Coupling	Coupling Weight
		"A"	"B"	"C"	Qty.	size	
Truss	219	356	127	268	4	M22 x 2.5 x 125	24
End Support	273	419		322			32

\* Use ASTM A183 bolts, with heavy hex nuts.

Note: Show, on the shop details, the type of pipe coupling used.

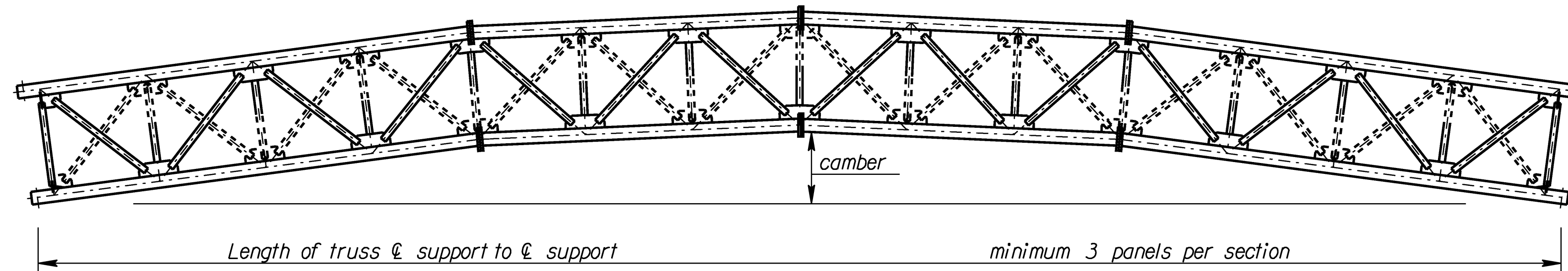

TRUSS CAMBER

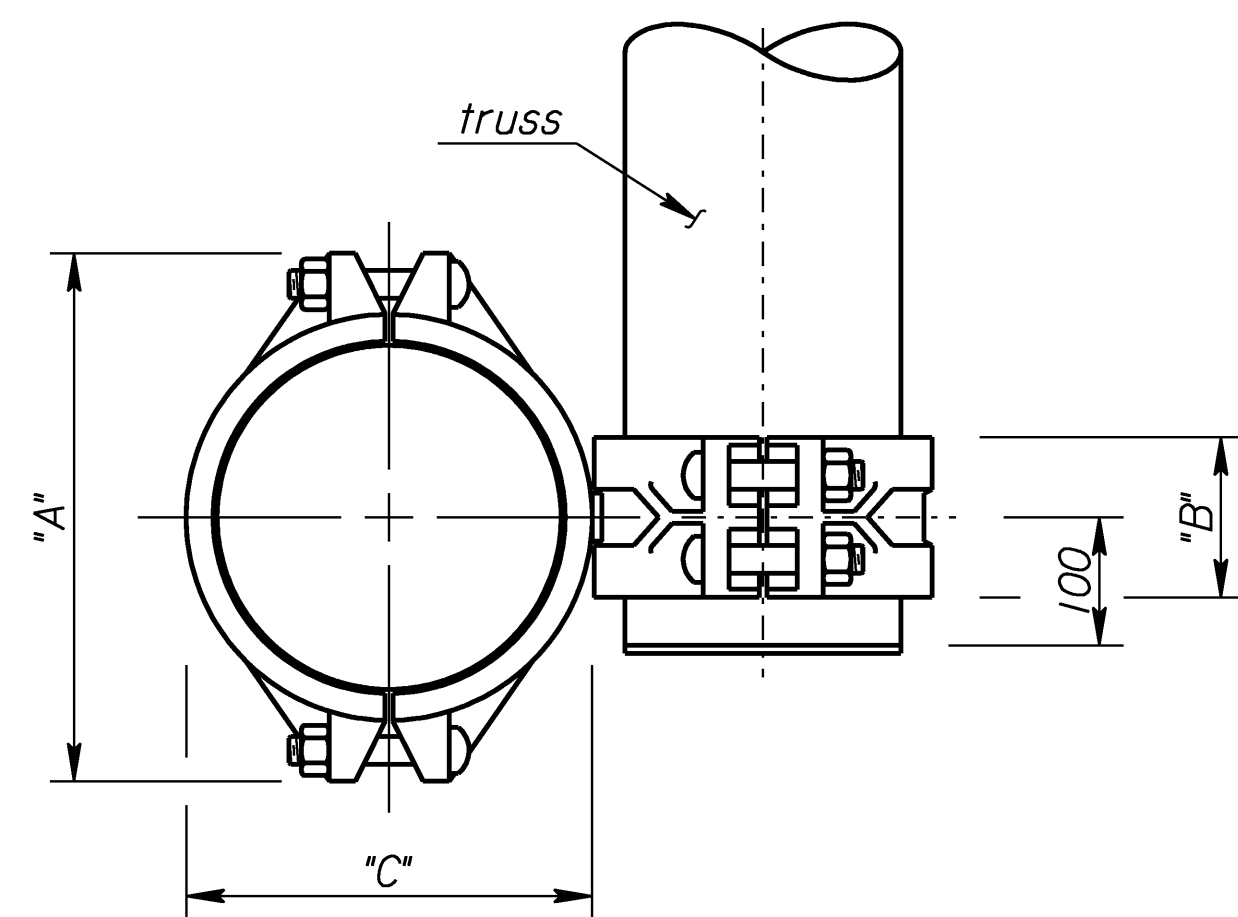

PLAN

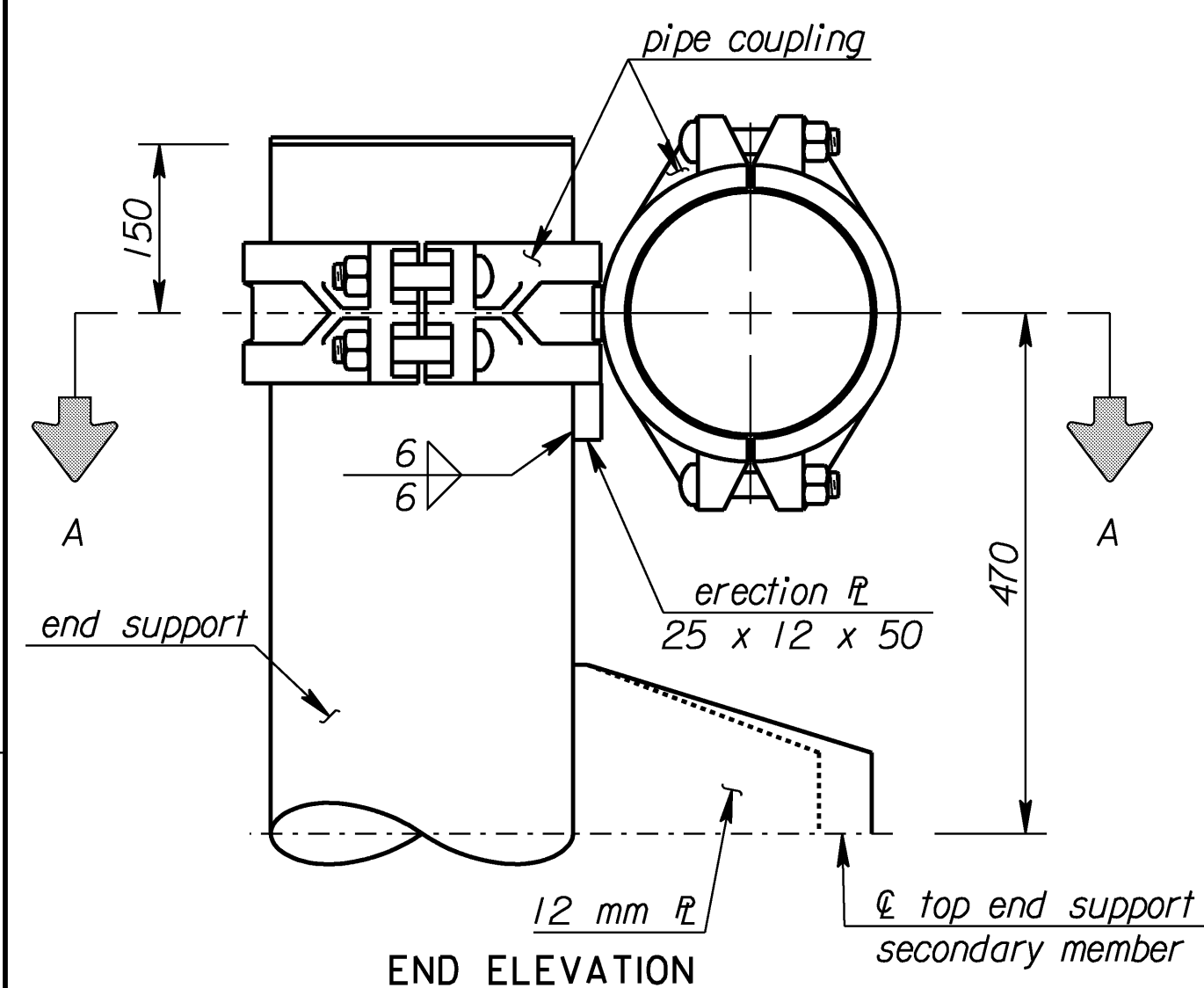

END ELEVATION

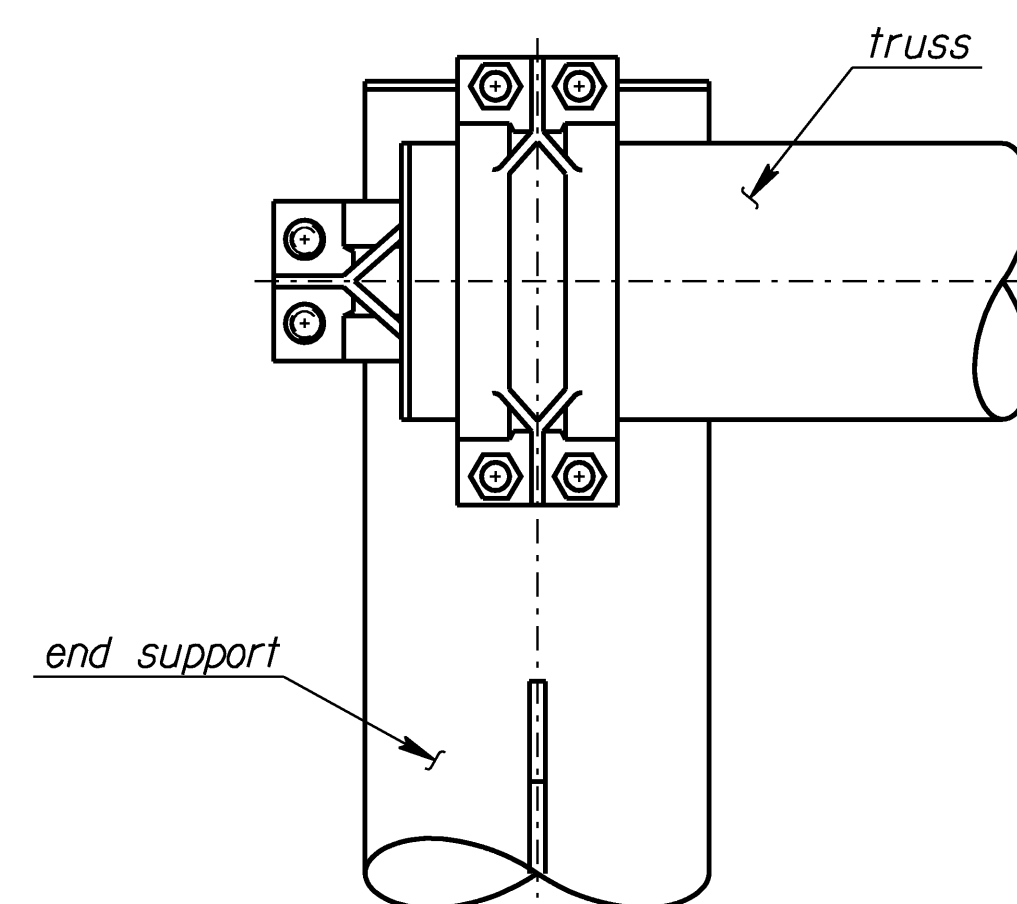

SIDE ELEVATION

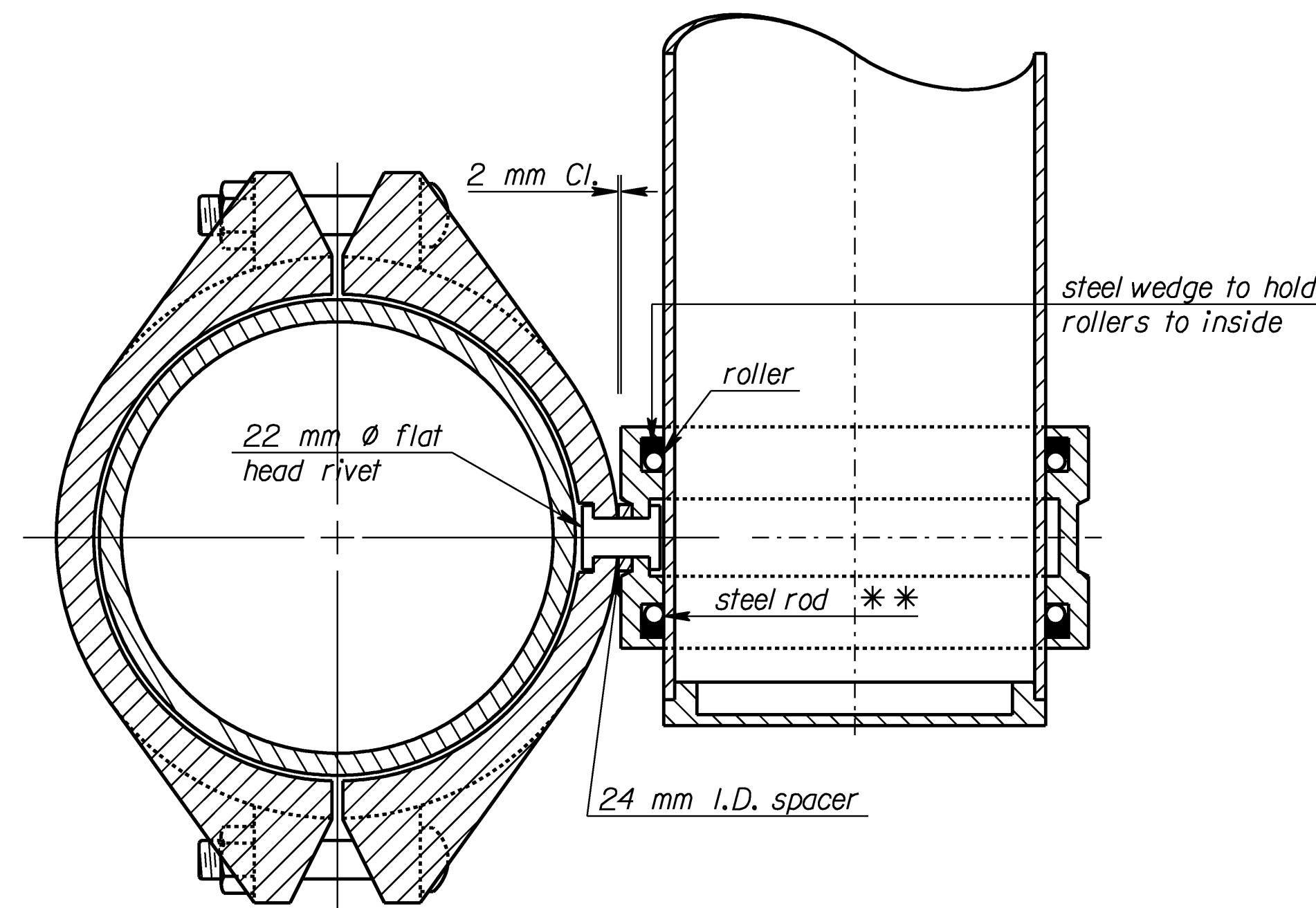

SECTION A-A

\*\* Replace every other factory roller (alternating sides) with a threaded rod. Use hardened threaded rods which are 19 mm ( $\pm 500 \mu\text{m}$ ) long by 14 288  $\mu\text{m}$  (+400  $\mu\text{m}$  or -130  $\mu\text{m}$ ) outside diameter. Use stainless steel rods which conform to ASTM A320/A320M and whose threads conform to 18NF Class 1A 14.

GENERAL NOTES

TRUSS TO END SUPPORT CONNECTION: Use cast pipe couplings equipped with serrated rollers, with housings drilled and spot faced for rivet swivel. Wedge all factory rollers, to the inside edge as shown, to prevent movement between the coupling and the aluminum tube. Use housings which conform to ASTM A47M Grade 22010 or to ASTM A536 Grade 604510 and are hot-dip galvanized according to ASTM A123. Use rivets which conform to ASTM A502 Grade 2.

CAMBER: Camber the truss by the amount shown on the "Construction Layout" sheet, using one of the following methods:

- (1) Block the truss and then weld at the joints and weld the splice flanges into place.
- (2) Increase the length of the top truss chords, making sure the splice flanges will be parallel in the field.
- (3) Place light gage spacer plates on the top splice flanges to obtain an increase in the top truss chord as in (2).

BOLT TORQUE: Torque the coupling bolts to 400 Nm using the calibrated wrench method.

Std. Base File: sl151bsi.dgn - Plot 6  
 Plotted By: bond  
 File: F:\Working\825801\SL\_Structures\SL-825801-151bsi.dgn  
 Plot Date: 6/29/2005

NO.	DATE	REVISIONS	BY	APP'D
<b>KANSAS DEPARTMENT OF TRANSPORTATION</b> <b>STANDARD STRUCTURAL SIGN SUPPORTS</b> <b>SPAN TYPE OVERHEAD</b> <b>ALUMINUM ALTERNATE</b> <b>TRUSS TO END SUPPORT CONNECTION AND CAMBER DETAILS</b> <b>SL151B-06 SI</b>				
			<b>SEDGWICK CO.</b>	
DESIGNED	BFM	DETAILED	DDP	QUANTITIES
DESIGN CK.	RDH	DETAIL CK.	RDH	QUAN. CK.
			Kenneth F. Hurst CADD DJE CADD CK. LES	