

| | | |
|------|---------|------|
| PLAN | CHECKED | DATE |
| | CHECKED | |

| | | |
|---------|---------|------|
| PROFILE | CHECKED | DATE |
| | CHECKED | |

Drawn: 06-29-2010 3:31:41 PM by JLM
 Plot Scale: 1/4" = 10' - 01-2010 11:17:24 AM by JLM
 G:\2009\08307\000\WL\08307-C-WLPR02

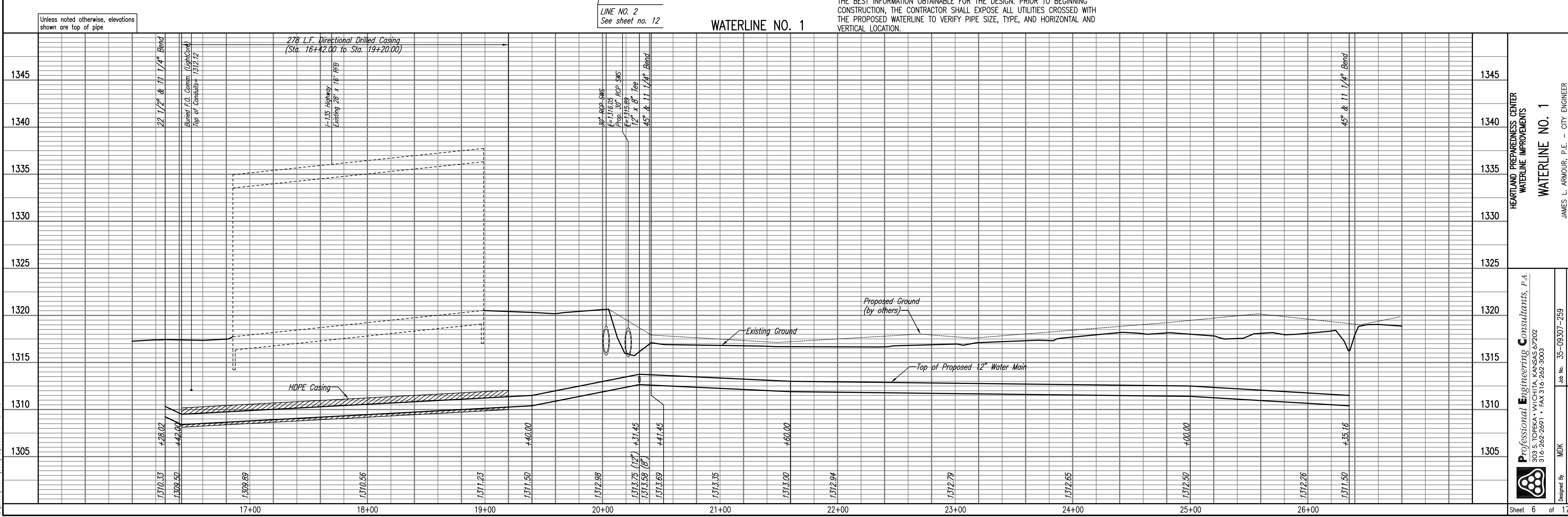
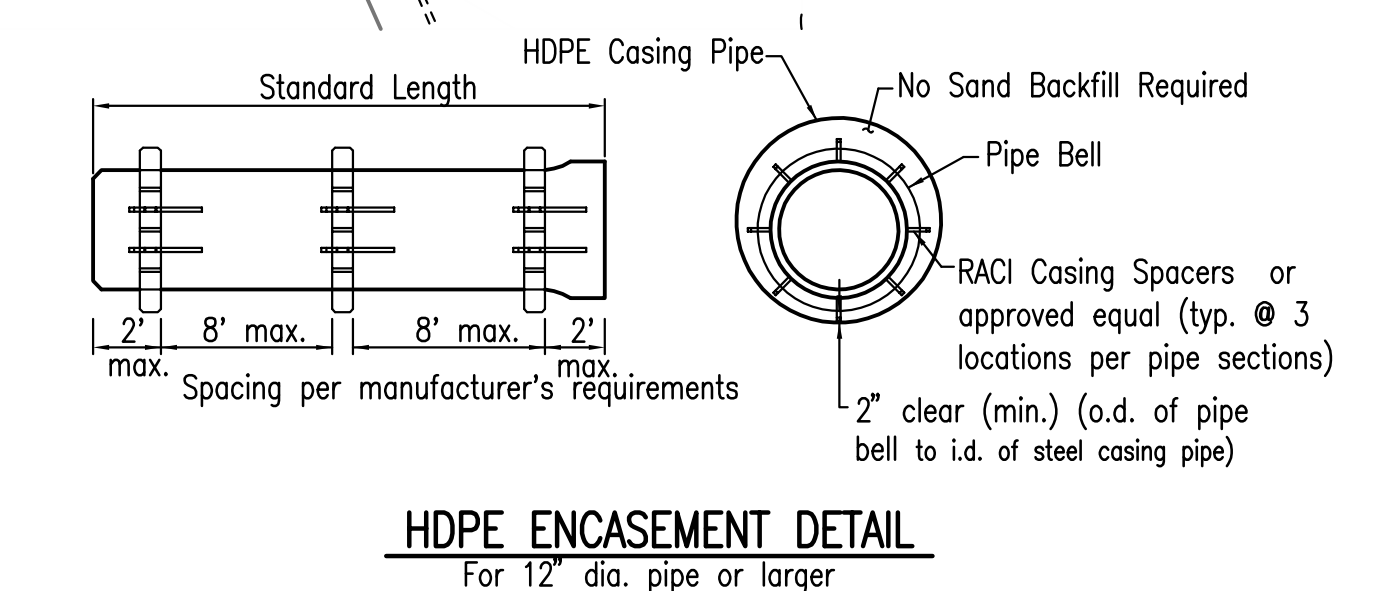
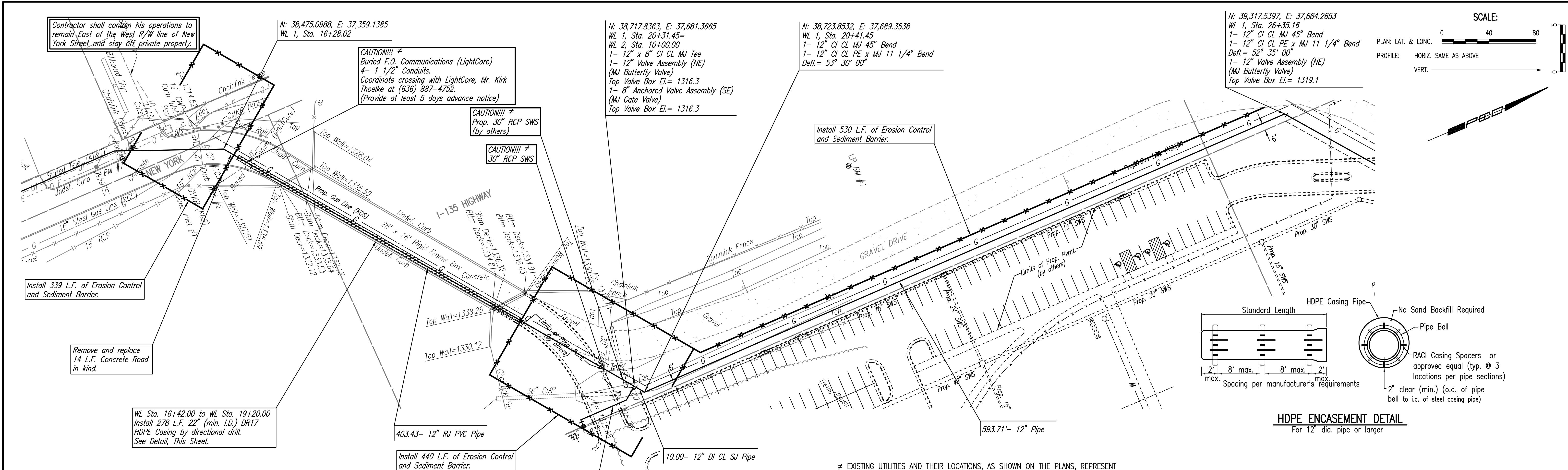

Professional Engineering Consultants, P.A.
 603 S. TOPICKA AVENUE, WICHITA, KANSAS 67202
 316-262-2691 • FAX 316-262-3003

HEARTLAND PREPAREDNESS CENTER
 WATERLINE IMPROVEMENTS
WATERLINE NO. 1

Designed By: MDK
 Drawn By: JLM
 Job No.: 35-09307-259
 Date: January 2010

JAMES L. ARMOUR, P.E. - CITY ENGINEER
 CITY OF WICHITA PROJECT NO. 448-90476

Sheet 6 of 17