

BY	DATE

Plotted on: 04-JAN-2005 13:28 \*time\$  
 dJamison Plot Queue: #queue\$  
 Plot Scale: #scale\$ Pen Table: #pentables  
 Design Filename: k:\b29049\BridgesDec2004\Base Bid\01s+Street\drawings\fl8.dgn

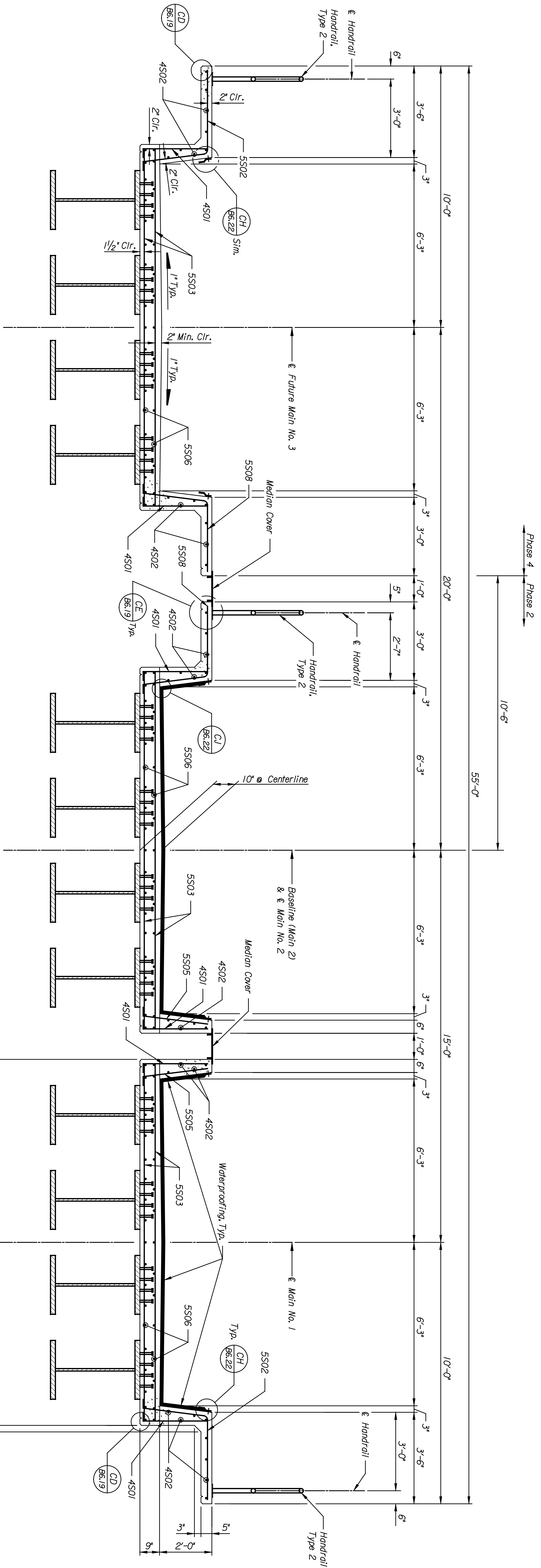

**TYPICAL DECK SECTION CA**  
 Scale: 1/2" = 1'-0"  
 (B6.18)

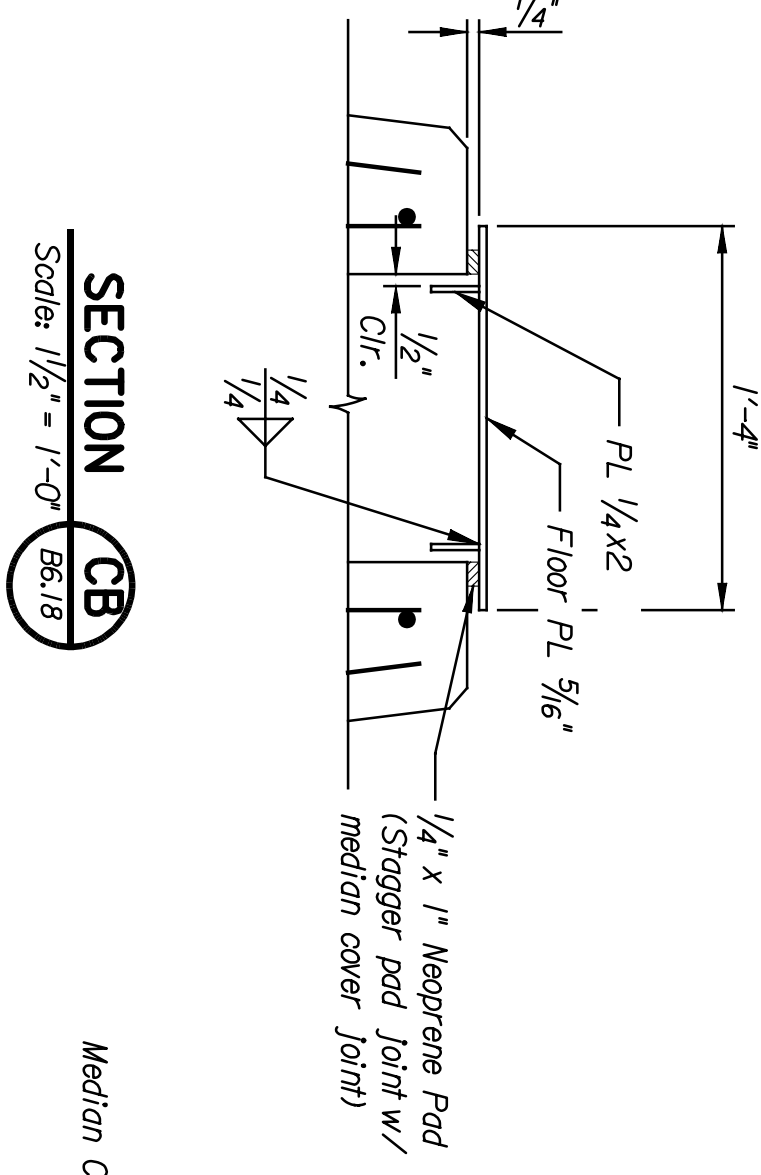

**SECTION CB**  
 Scale: 1/2" = 1'-0"  
 (B6.18)

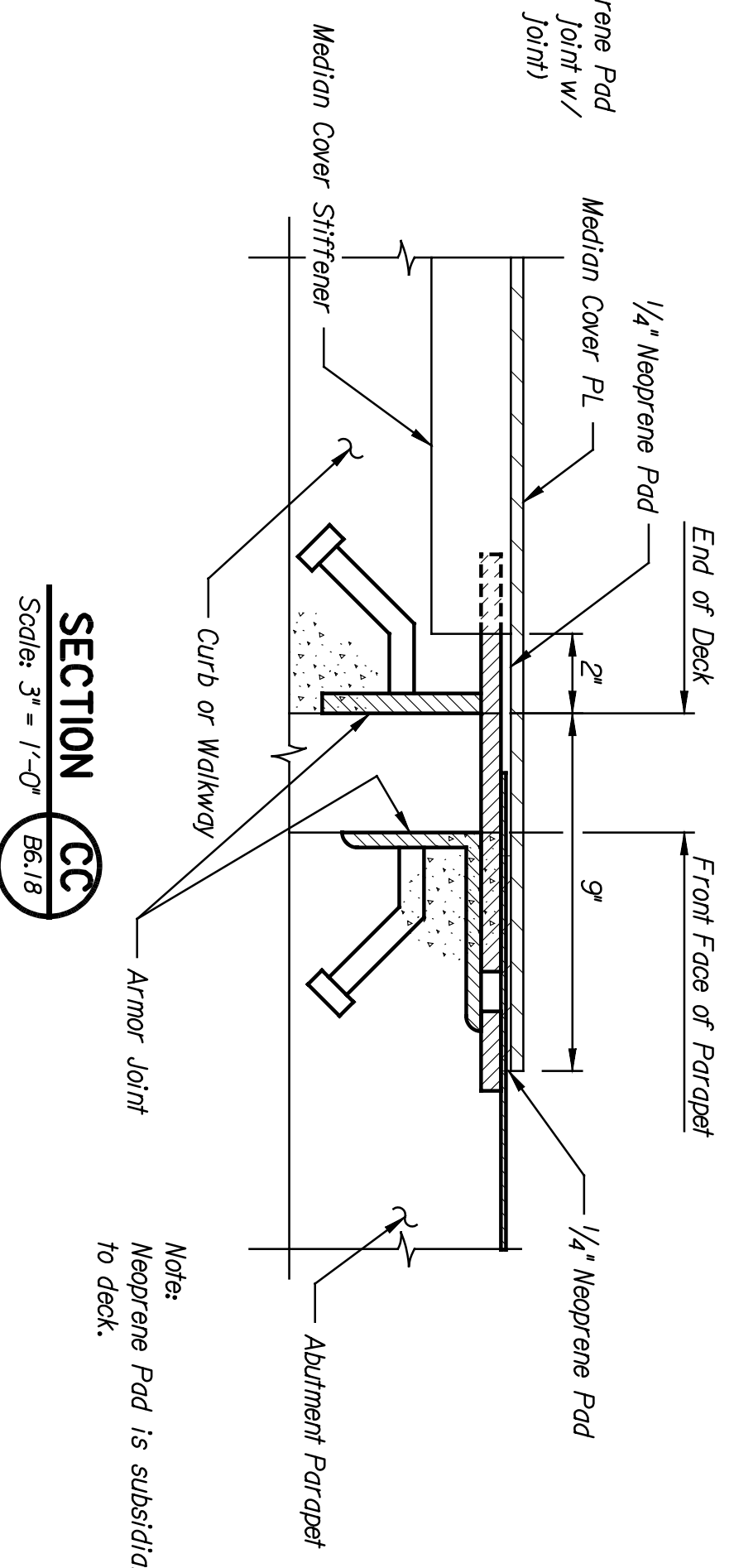

**SECTION CC**  
 Scale: 3" = 1'-0"  
 (B6.18)

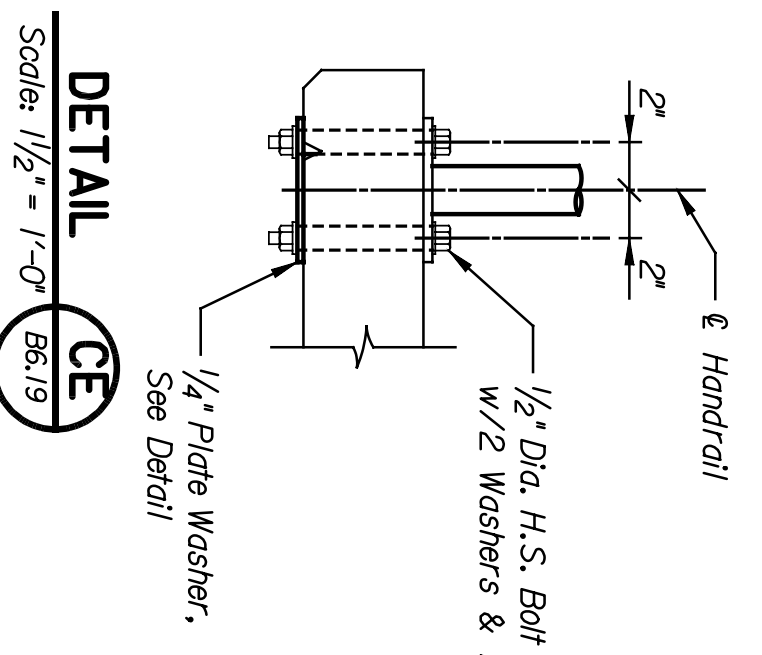

**DETAIL CE**  
 Scale: 1/2" = 1'-0"  
 (B6.19)

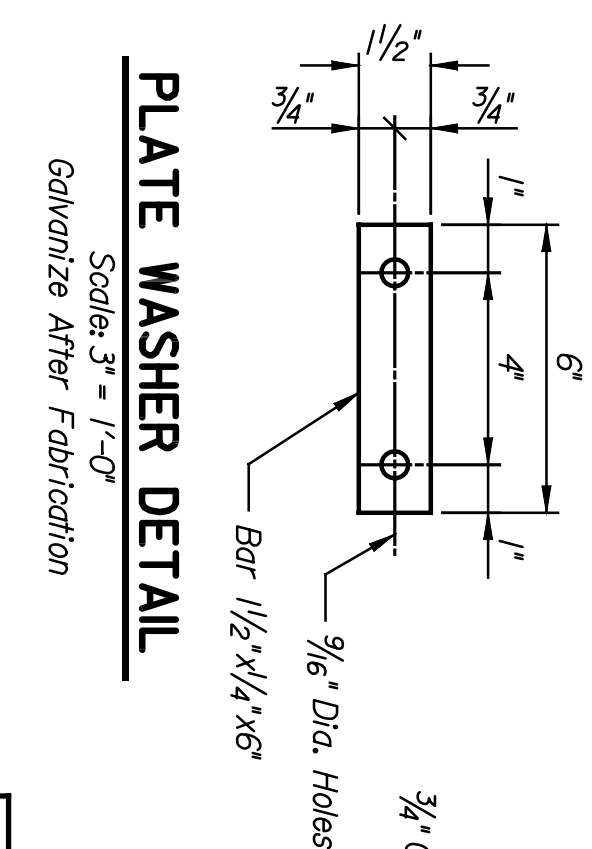

**PLATE WASHER DETAIL**  
 Scale: 3" = 1'-0"  
 Galvanize After Fabrication

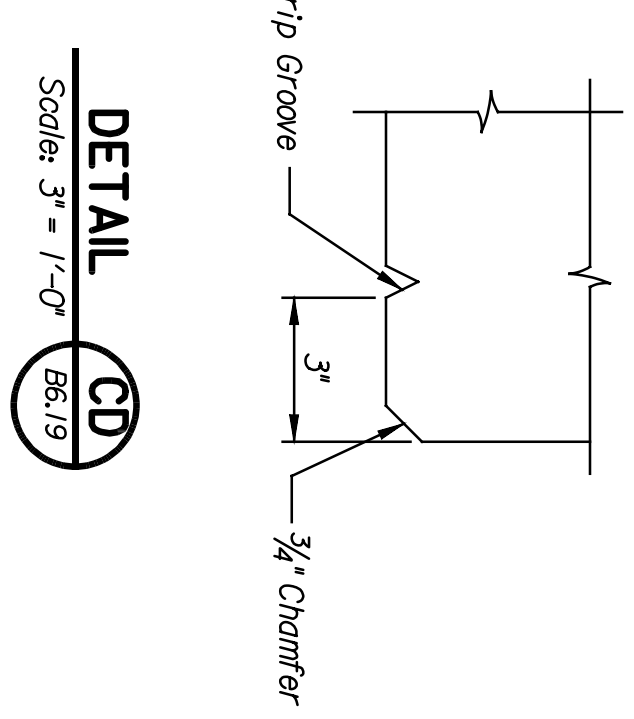

**DETAIL CD**  
 Scale: 3" = 1'-0"  
 (B6.19)

Notes:  
 Minimum Length of Median Cover Plate, 5'-0"  
 Maximum Length of Median Cover Plate, 8'-0"

This sheet designed by:



ARCHITECTS ENGINEERS PLANNERS

STATE	PROJECT NO.	YEAR	SHEET NO.	TOTAL SHEETS
KANSAS	472-84071	2005	B6.19	

LOCATION:	WICHITA, KS	
PROJECT:	LINE SEGMENT 7400	
DESIGNER:	DMH	
DATE:		
NO.	BY	APP'D.
1		
2		
3		

**CITY OF WICHITA**  
**1ST STREET**  
**DECK SECTION & DETAILS**

SHEET NO.	08	SCALE	AS NOTED	APP'D.	
DESIGNED	EKO	DETAILED	DJA	QUANTITIES	DJA
DESIGN GR.	DMH	DETAIL GR.	JWH	DRAWINGS	DMH
				TRACE	GR.
				CHK.	DMH