

STATE	PROJECT NO.	YEAR	SHEET NO.	TOTAL SHEETS
KANSAS	54-87 K-8258-01	2007	89	556

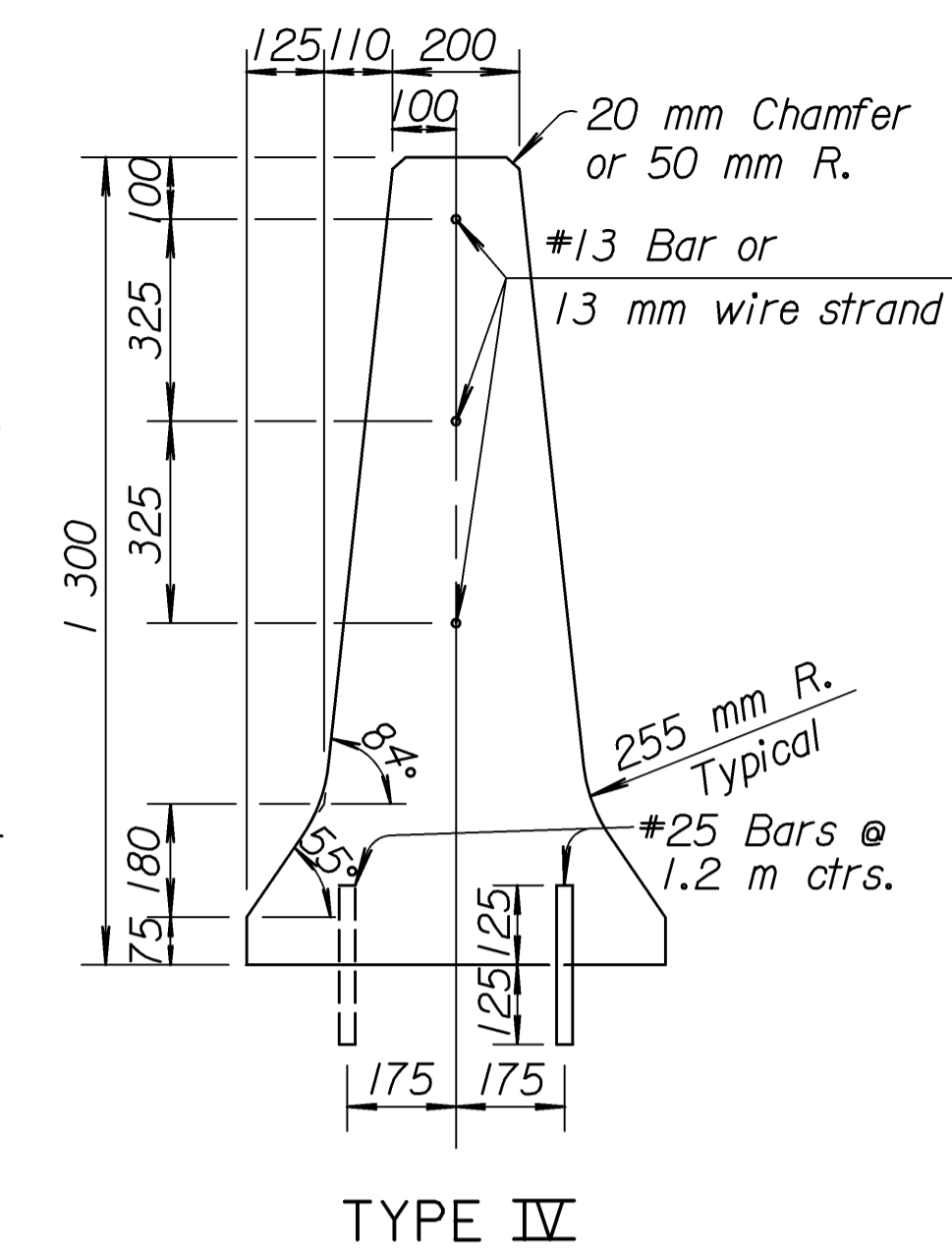
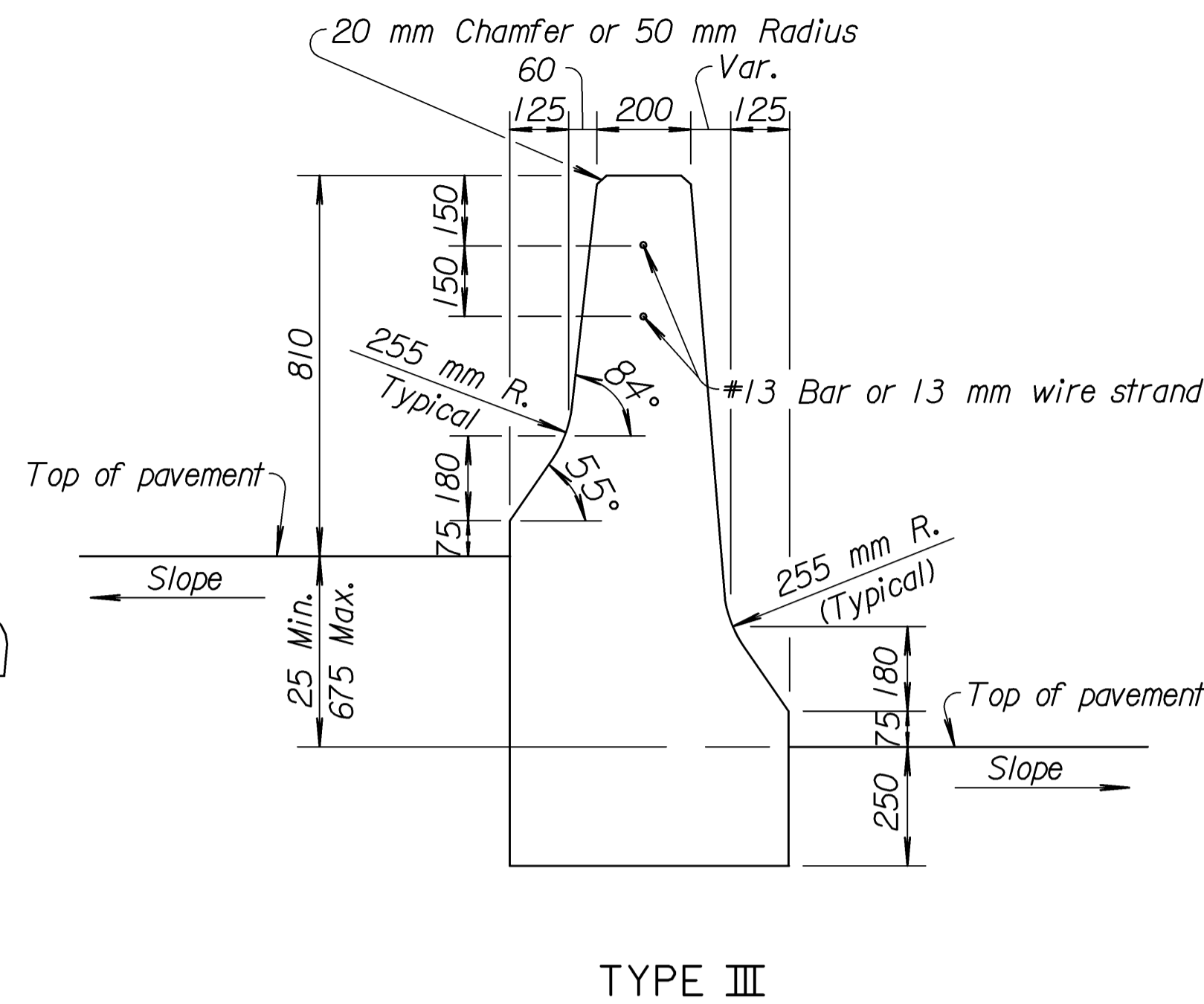
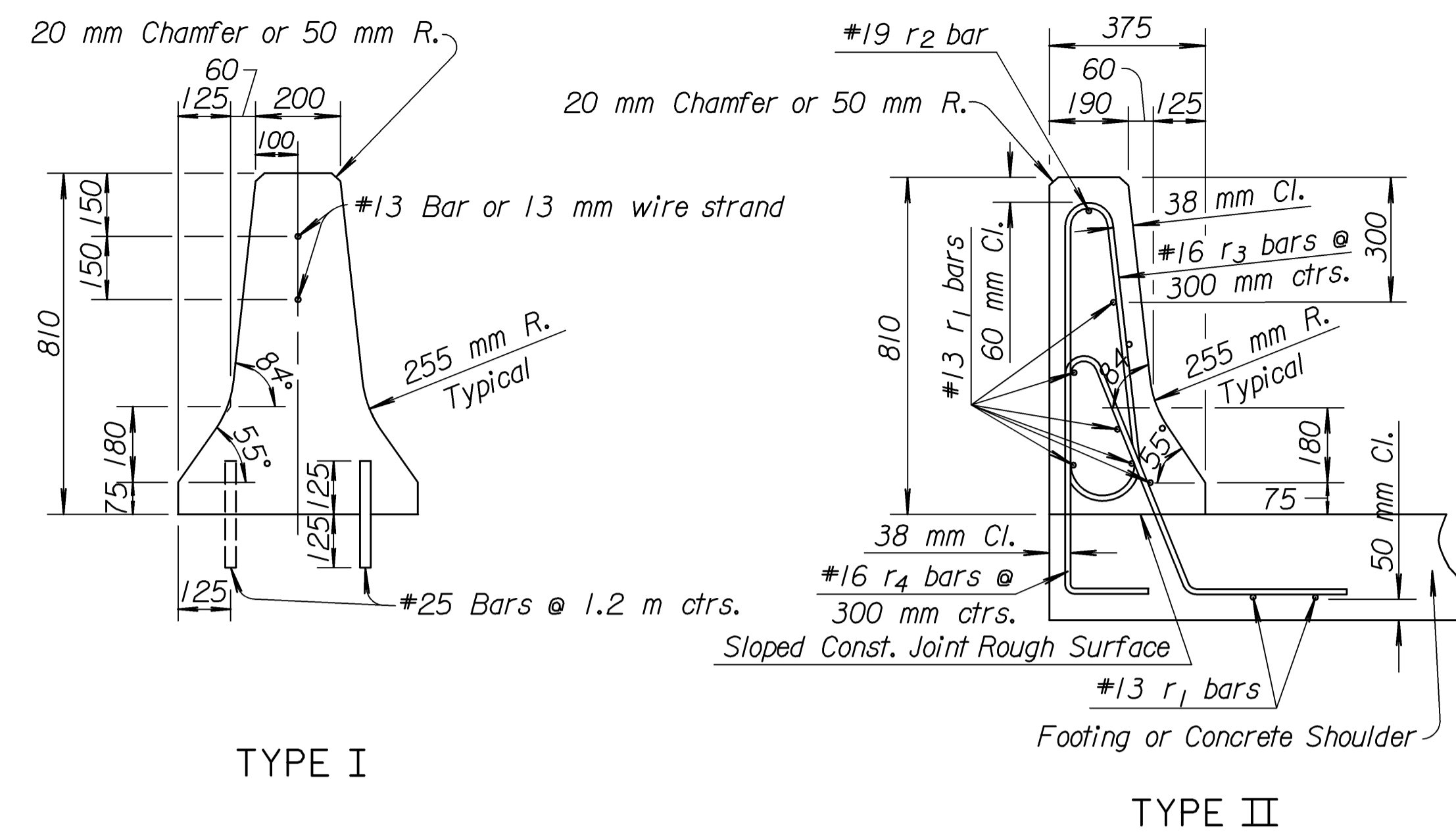

**GENERAL NOTE**  
Use either Concrete Grade 21 (AE) or the mix used in the concrete pavement throughout.  
Drainage slots shall be constructed where specified in the Plans, at inlet locations, or as directed by the Engineer.  
Bars designated by number, e.g., #25 bars, are deformed reinforcing bars, intermediate grade.  
Payment for all bars, joint material, median barrier filler material, reflectors and supporting materials, associated work, etc., shall be subsidiary.  
The section furnished must generally comply with the dimensions shown. Requests for minor variations in section geometry may be submitted for review.  
Permanent concrete barriers shall be cast in place or slip formed construction only. Precast barriers will not be permitted.

**EXPANSION JOINTS**  
Expansion Joints shall be made of Expansion Joint Material (Nonextruding, Type B), 25 mm thick, and constructed where shown, to match expansion joints in concrete pavement; at structures; and at the end of each day's pour. Where pavement joints are greater than 38 mm in thickness, the joint may be left open with no joint material above the adjoining surface. Expansion joint material shall be recessed 6 mm from barrier surface.

**CONTRACTION JOINTS**  
Contraction Joints may be either formed or sawed on 6 m centers maximum. Where barrier is placed on or adjacent to concrete pavement, joints shall be spaced to match contraction joints and definite transverse cracks in the pavement, not to exceed 12 m centers.

**BARRIER BASE**  
Where the median is not paved full width, barrier shall be placed on a 250 mm x 600 mm bed of Concrete Grade 21 or the mix used in the concrete pavement, or bituminous base course, at the contractor's option with approval of Engineer, to assure proper alignment.

**100 mm PRESSURE RELIEF JOINT**  
Joint material shall be preformed urethane foam joint material installed with lubricant adhesive, cut to the shape shown. The joint shall be constructed to match the 100 mm pressure relief joint of the concrete pavement approach slabs. Approximately three-fifths of the length of each dowel bar shall be coated with a hard grease prior to installation.  
The cutting to length of the dowel bars shall be done in such a manner to result in no appreciable deformation of the ends.  
Each dowel bar shall be coated with an epoxy coating with the average film thickness of not less than 0.25 mm, with individual determinations within a tolerance of +/- 0.08 mm of the average. The coating material shall be a powdered epoxy resin approved by the Engineer of Materials and shall be uniformly applied according to accepted practices and the resin manufacturer's recommendations.  
All work and materials required for installation of joint material shall be subsidiary to Concrete Safety Barrier and shall conform to the Standard Specifications.

**DELINEATION**  
See Standard Drawing RD649 SI for details of barrier delineation.

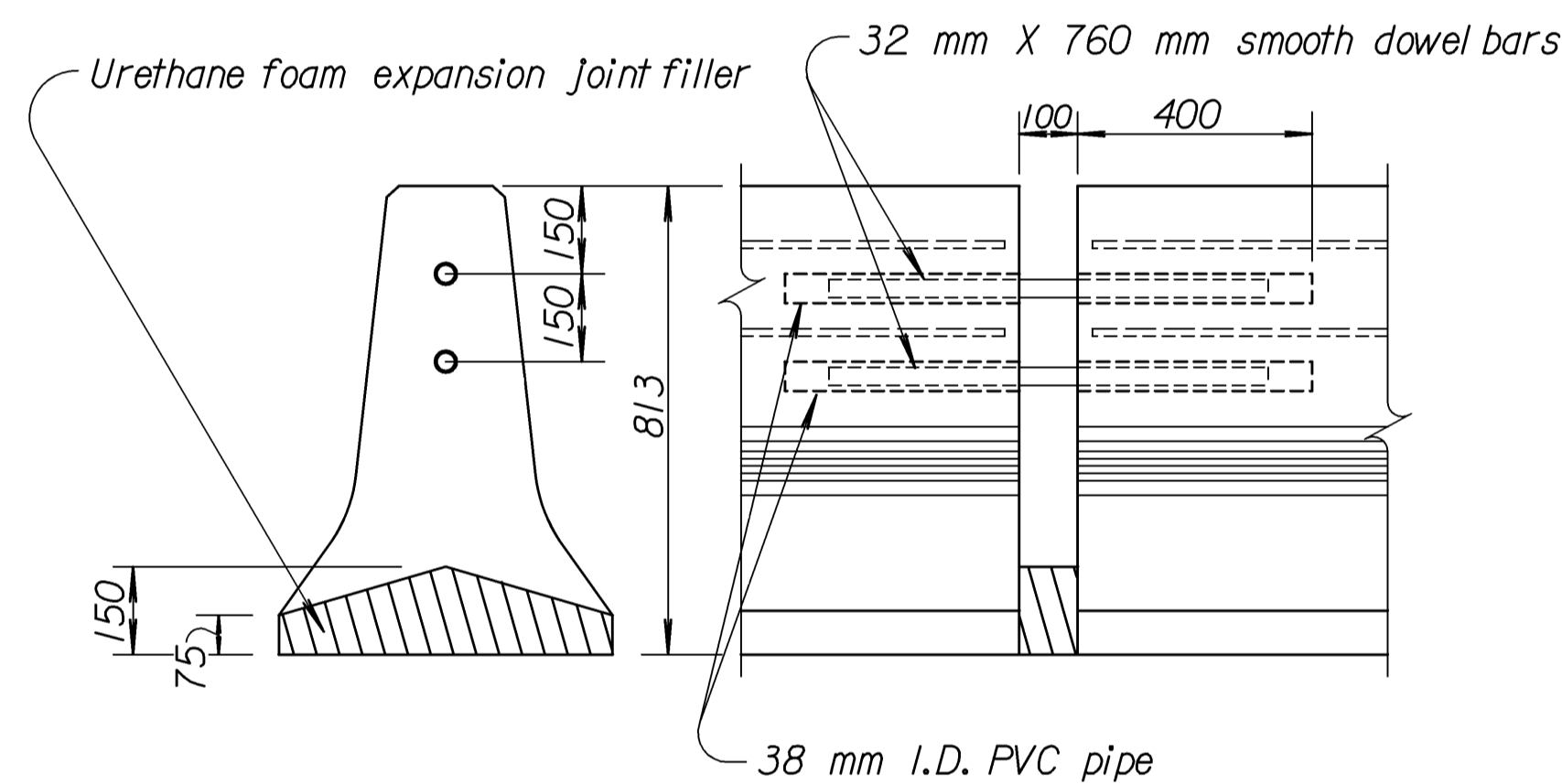

**PRESSURE RELIEF JOINT**  
Pressure relief joint will match relief joint in bridge approach slab.

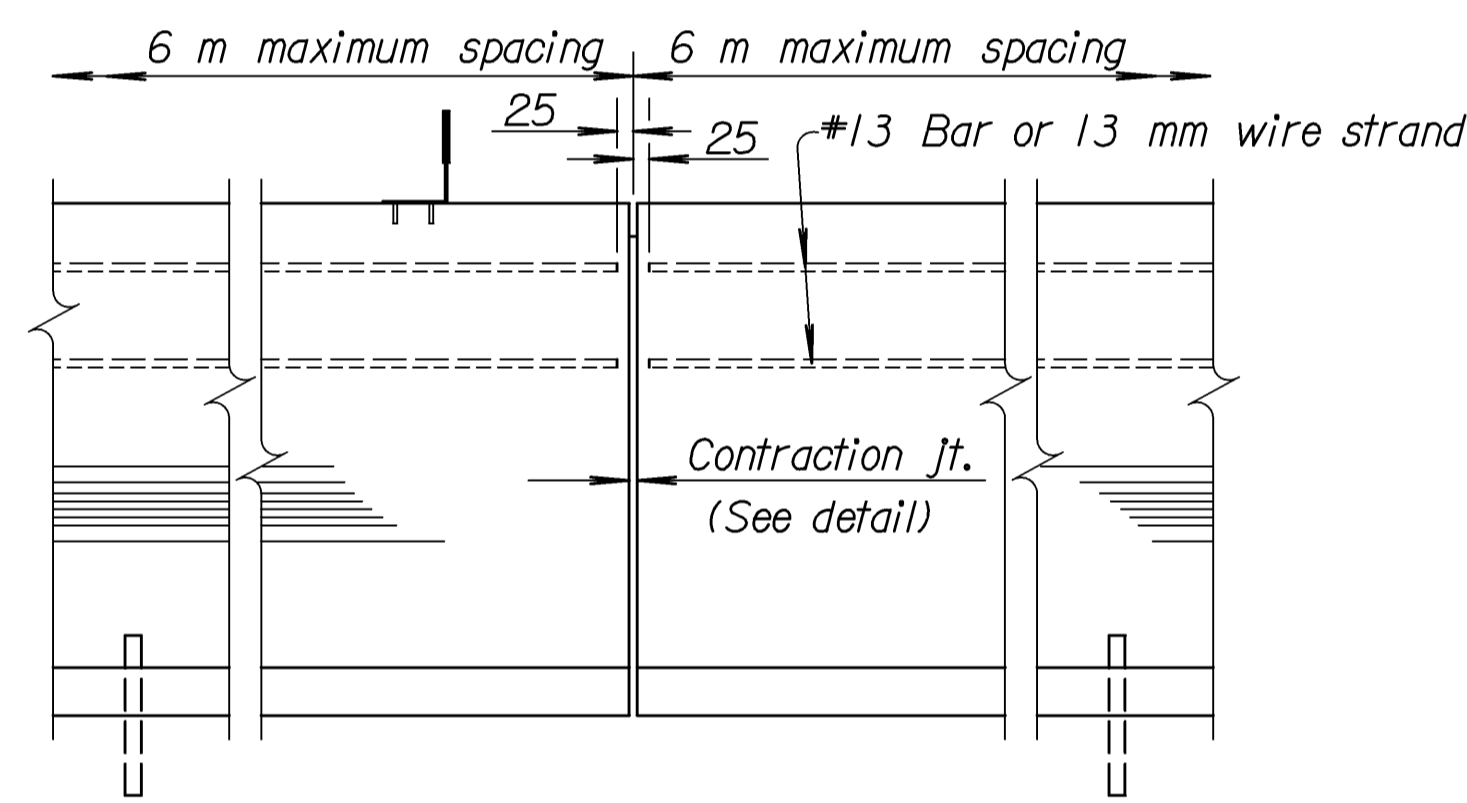

**ELEVATIONS**

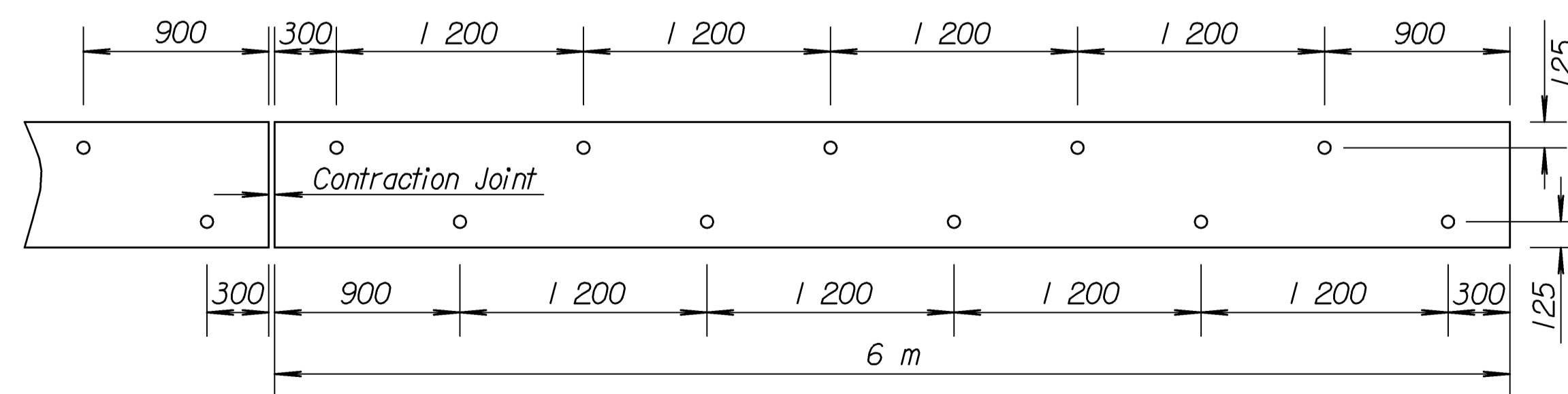
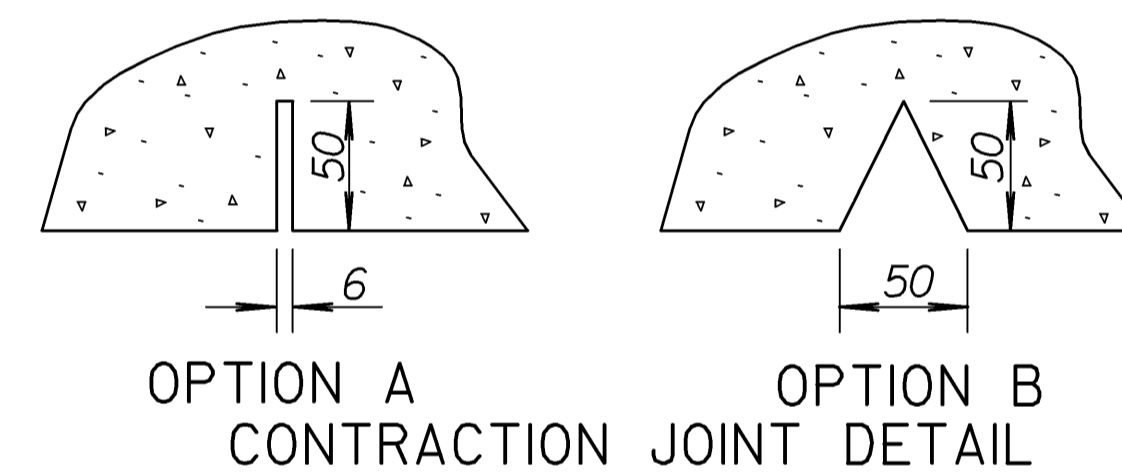

**DOWEL PLACEMENT DETAIL (TYPE I & IV)**

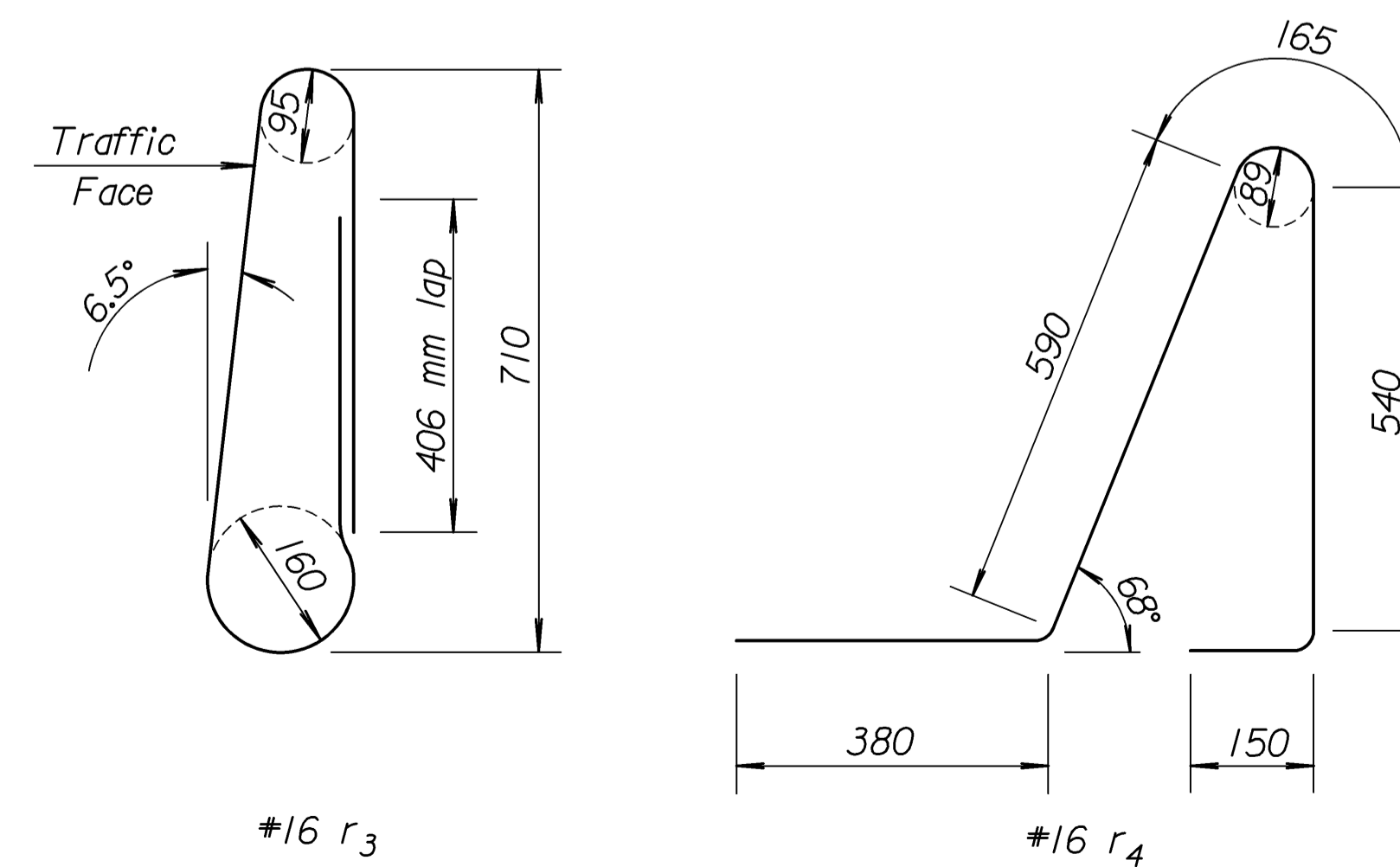

**BENDING DIAGRAMS**  
Note: All dimensions are out to out of bars.

Drawn By: \$\$\$USERNAME\$\$\$ Plotted: \$\$\$SYTIME\$\$\$  
File: \$\$\$FILENAME\$\$\$

NO.	DATE	REVISIONS	BY	APP'D
3	2-08-05	Revised concrete Grade	S.W.K.	J.O.B.
2	4-30-02	Rev. concrete from Class to Grade	S.W.K.	J.O.B.
1	12-12-00	Revised bending diagram	R.J.S.	J.O.B.

KANSAS DEPARTMENT OF TRANSPORTATION  
**PERMANENT CONCRETE SAFETY BARRIER TYPE I, II, III & IV (F-SHAPE)**  
RD632 SI

DESIGNED	5-25-05	APP'D	James O. Brewer
DESIGN CK.	DETAIL CK.	QUAN. CK.	TRACE CK. Seltz