

E.F. INDICATES EACH FACE.  
N.F. INDICATES NEAR FACE.  
F.F. INDICATES FAR FACE.

STATE	PROJECT NO.	YEAR	SHEET NO.	TOTAL SHEETS
KANSAS	54-87 K-8258-01	2007	203	556

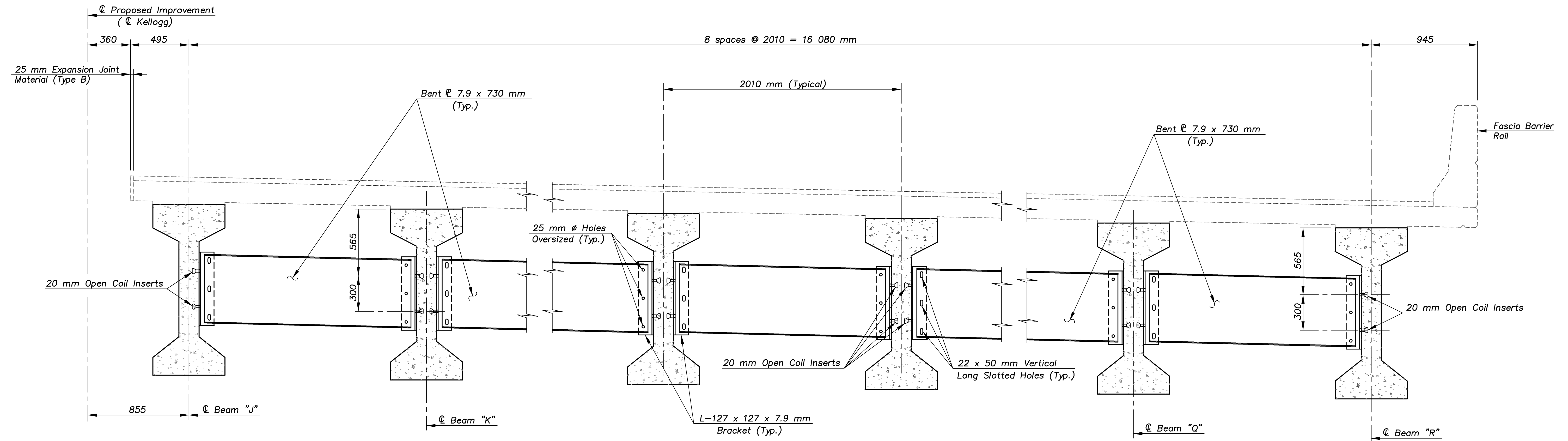

**ELEVATION OF TEMPORARY DIAPHRAGMS**  
(Looking Ahead Station)

**NOTE:** Use standard holes in the angle bracket, oversized holes in one end of the bent plate diaphragm and vertical long slotted holes in the other end of the bent plate diaphragm. A hardened steel washer is required at oversized holes and a plate washer is required at the slotted hole locations.

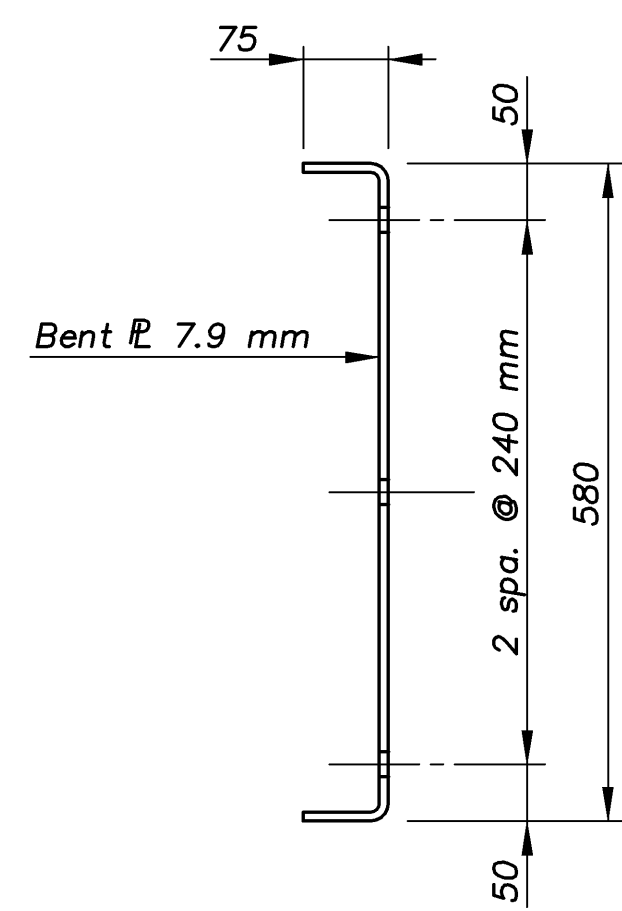
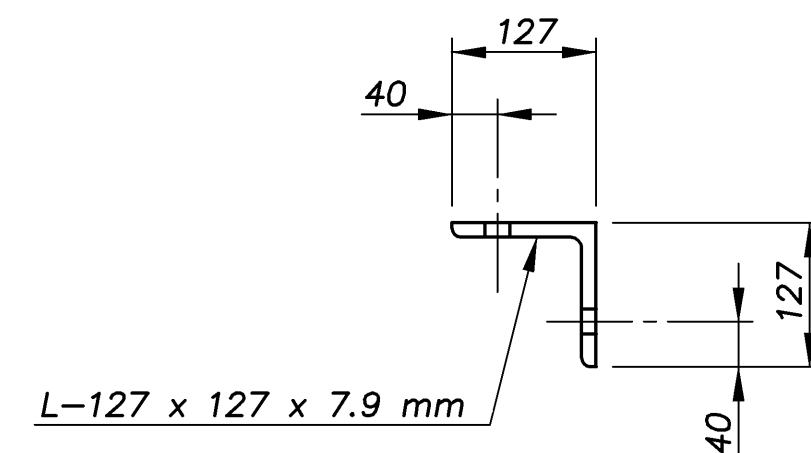
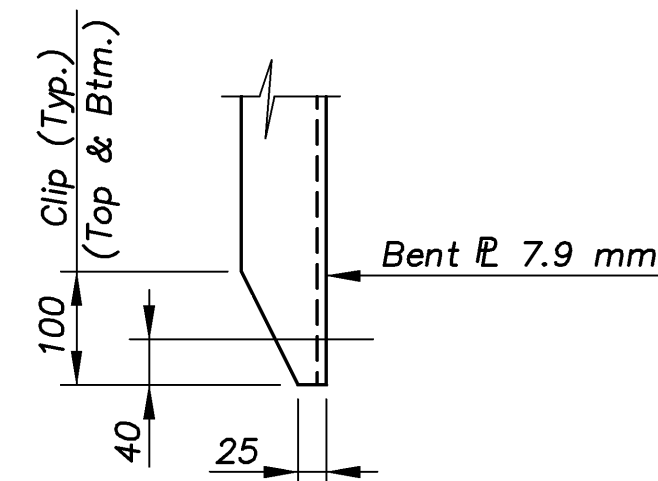

**BENT PLATE**

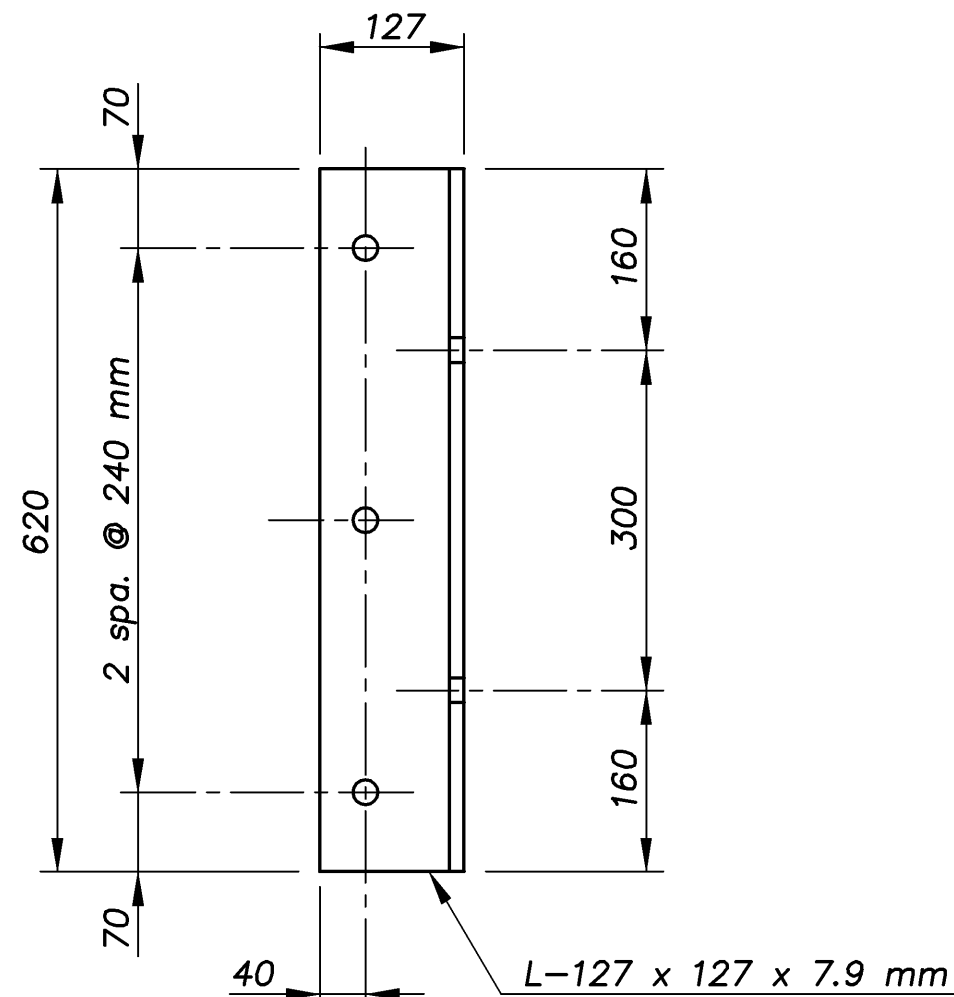

**BRACKET**

Use 22 mm  $\phi$  Holes for 20 mm Bolts in Brackets.

**TEMPORARY DIAPHRAGMS NOTES**

Use ASTM A709M Grade 250 steel for all angles and bent plates for the temporary diaphragms. All bolts, nuts and washers for fasteners shall conform to the heavy hex structural requirements of ASTM A325M, Type I. Use hardened steel washers over any oversized holes. Use 8 mm plate washers over any slotted holes along with hardened steel washers under the turned elements. Use the turn-of-the-nut tightening method. DTI's are not required. U.S. Customary bolts are allowed. Install the temporary diaphragms, as shown in the details, prior to placing any superstructure concrete. Leave the temporary diaphragms in place until the concrete diaphragms and the deck have cured. Remove the angles from the girders and fill the holes in the prestressed beams with an approved epoxy grout. The bent plate diaphragms, angles, nuts, bolts and washers shall remain the property of the Contractor. Submit shop drawings of the temporary diaphragms to the KDOT Bridge Section for review and approval. The material, equipment and labor necessary for the installation and removal of the temporary diaphragms, including filling the bolt holes, shall not be paid for directly, but shall be subsidiary to the bid item "Prestressed Concrete Beams".

ARMOUR/DIAPHRAGMS 1:100

KANSAS DEPARTMENT OF TRANSPORTATION  
BR. NO. 54-87-30.81(701) E.B. STA. 3+378.725

**TEMPORARY DIAPHRAGM DETAILS**  
KELLOGG AVENUE OVER ARMOUR ROAD

Proj. No. 54-87 K-8258-01 SEDGWICK COUNTY



**Cook, Flatt & Strobel**  
ENGINEERS, P. A.

DESIGNED	R.S.C.	SCALE	Varies
DETAILED	T.R.G.	DATE	
QUANTITIES	T.R.G.	SHEET	23 OF 39