

NOTE: All horizontal dimensions are measured along centerline of Handrail.

E.F. INDICATES EACH FACE.
N.F. INDICATES NEAR FACE.
F.F. INDICATES FAR FACE.

STATE	PROJECT NO.	YEAR	SHEET NO.	TOTAL SHEETS
KANSAS	54-87 K-8258-01	2007	278	556

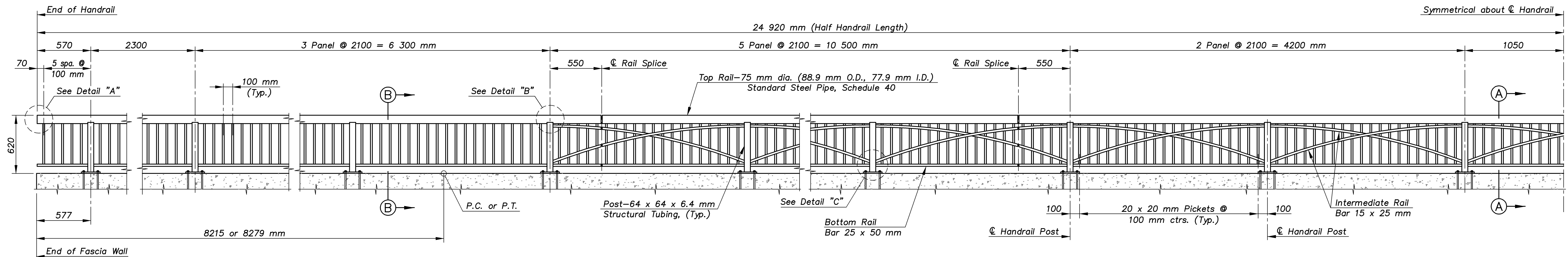

DEVELOPED TYPICAL ELEVATION OF HANDRAIL

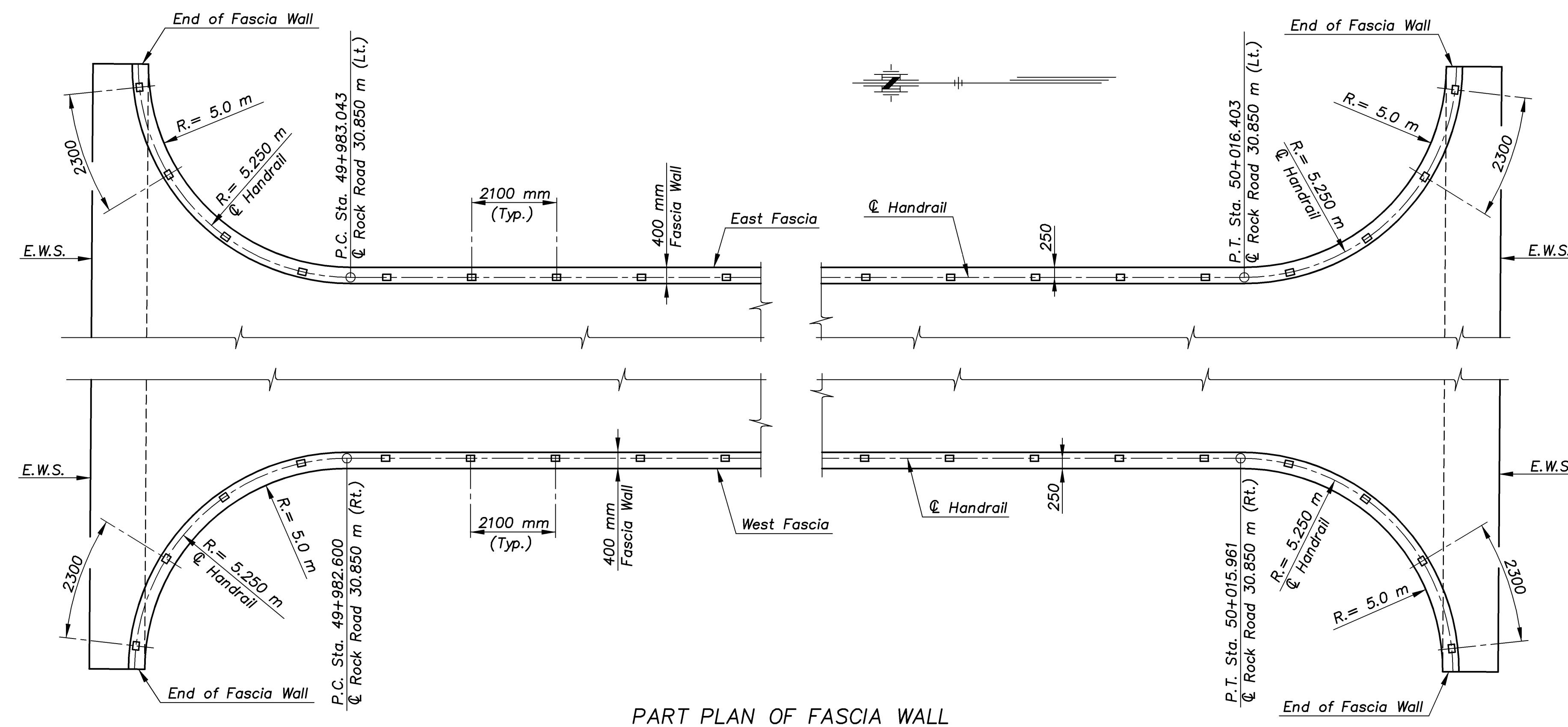
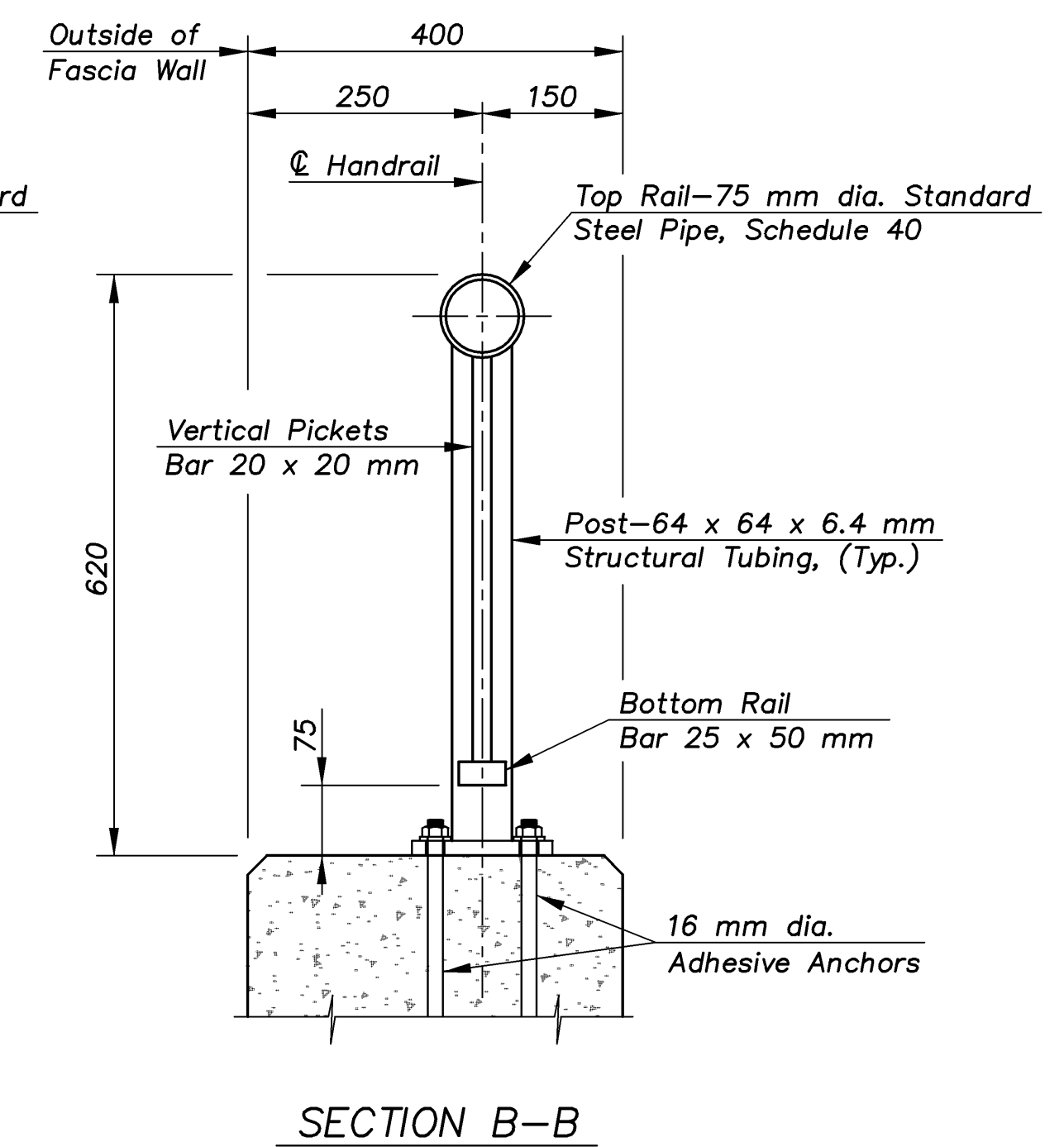
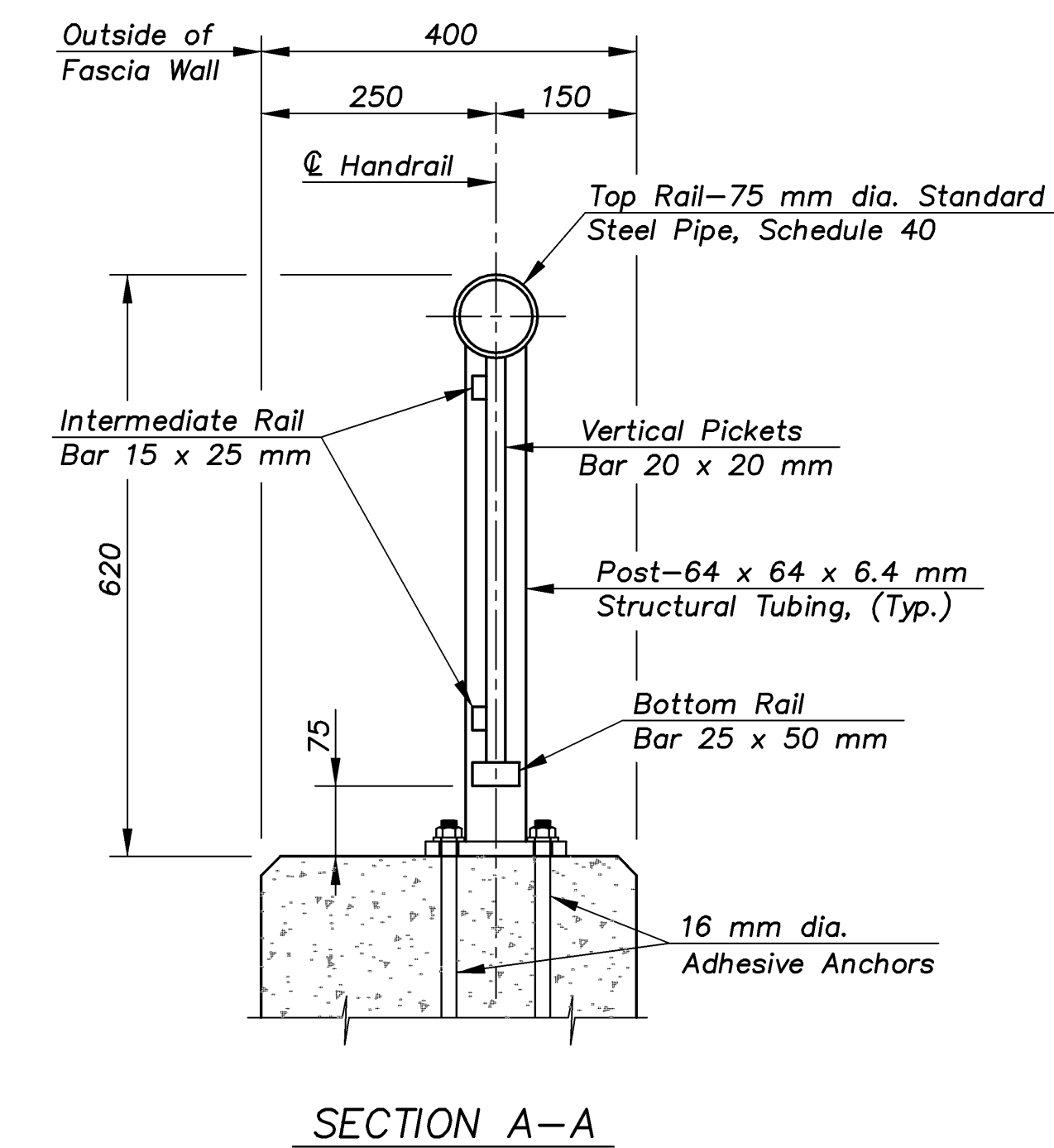
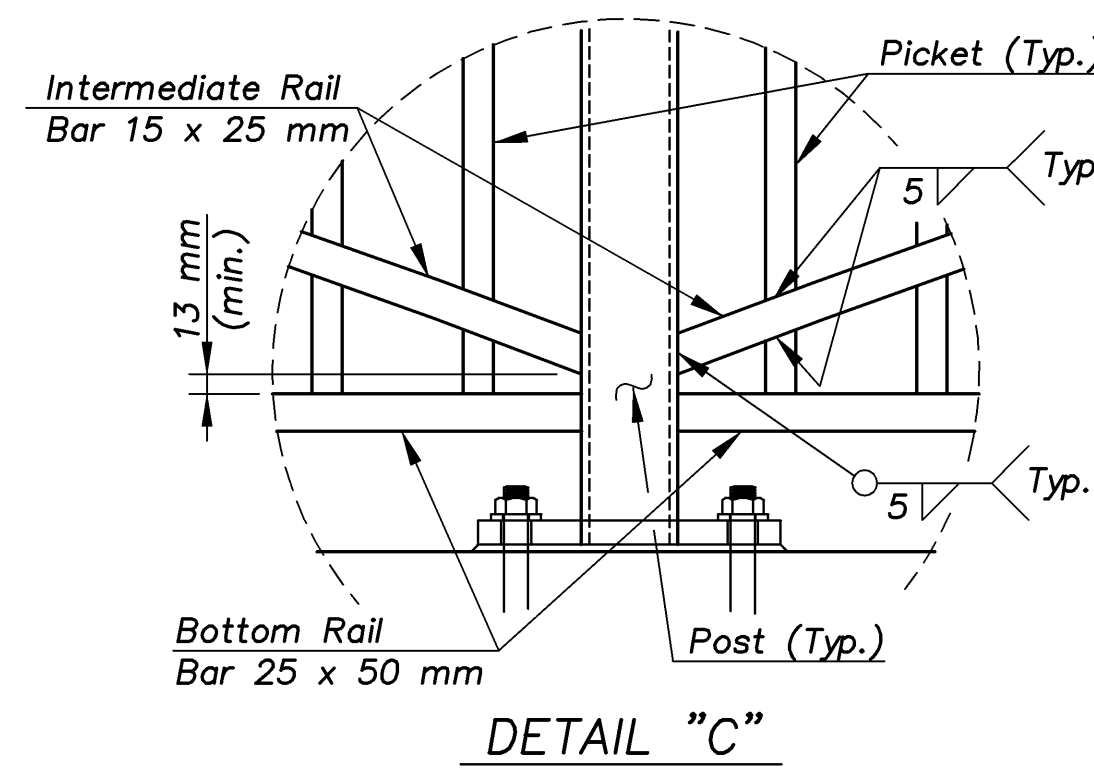
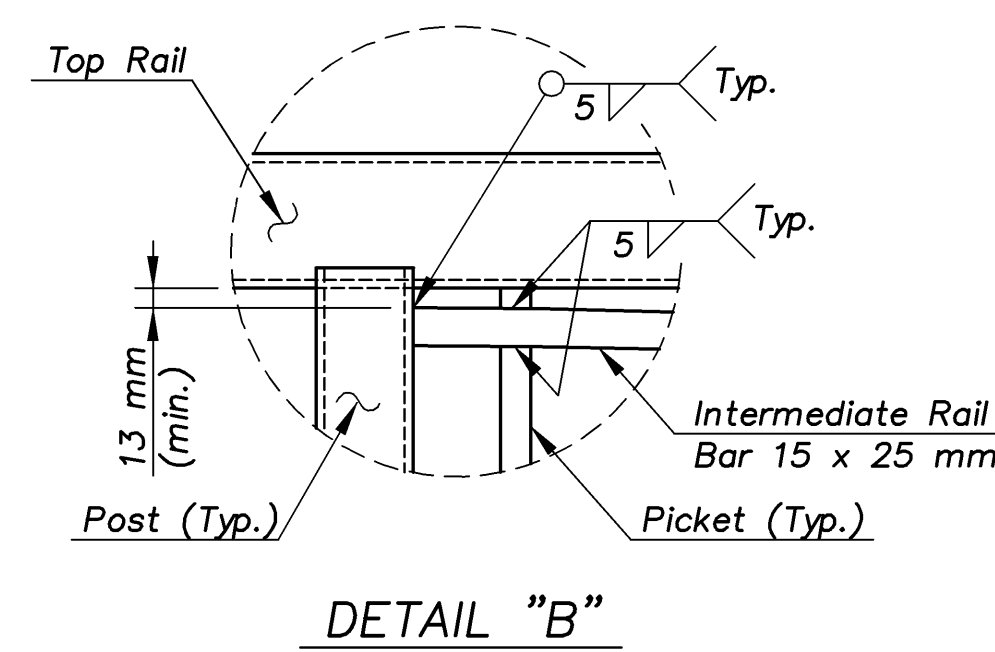
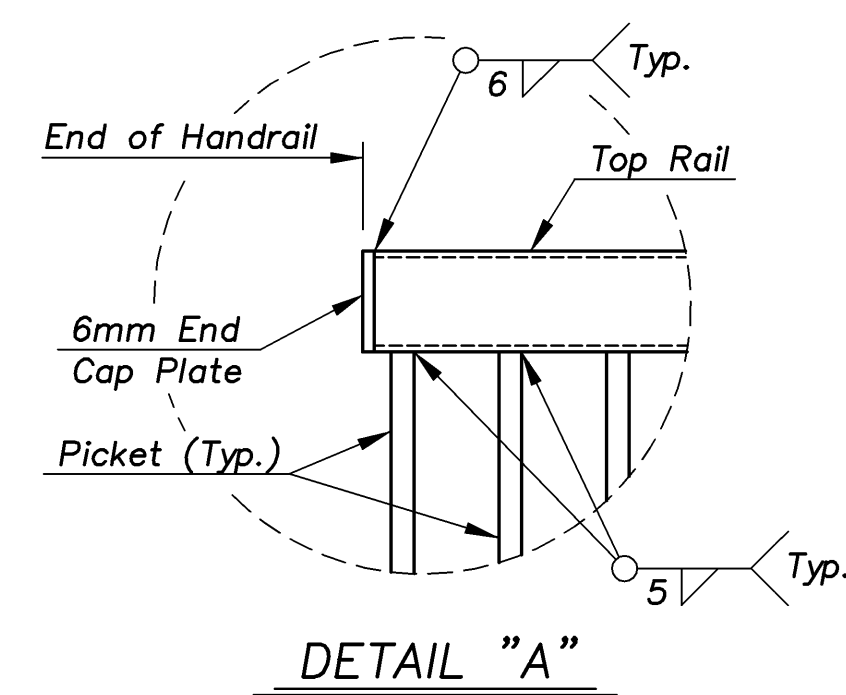

PART PLAN OF FASCIA WALL

KANSAS DEPARTMENT OF TRANSPORTATION
BR. NO. 54-87-31.12(702) STA. 3+877.518
BRIDGE HANDRAIL DETAILS
ROCK ROAD OVER KELLOGG AVENUE
Proj. No. 54-87 K-8258-01 SEDGWICK COUNTY

CFS
Cook, Flatt & Strobel
ENGINEERS, P. A.
DESIGNED R.S.C. SCALE Varies
DETAILED T.R.G. DATE
QUANTITIES T.R.G. SHEET 32 OF 41