

SERVICE BOX CONSTRUCTION/INSTALLATION DETAILS

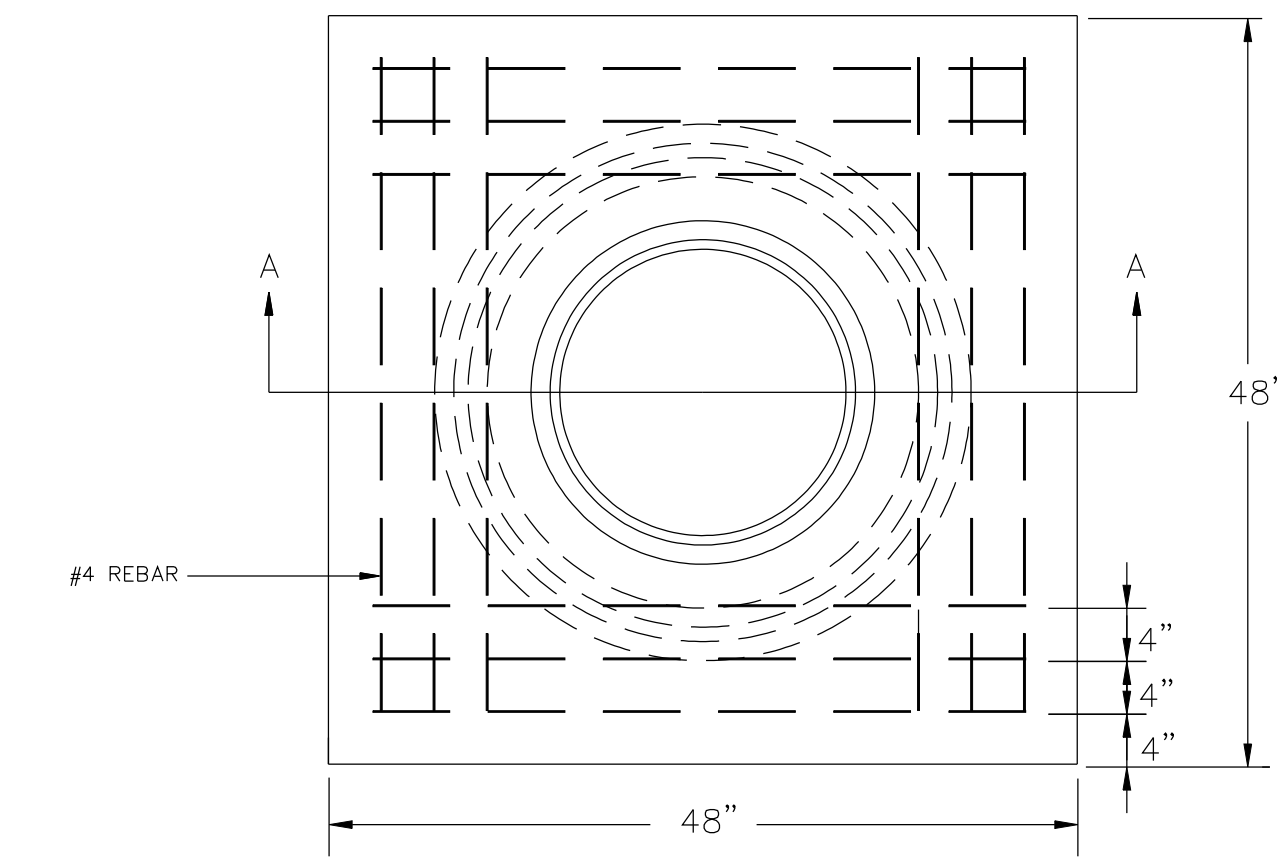

PRE-CAST CONCRETE SERVICE BOX
(36" I.D. X 54" RCP)
with 6" CAP

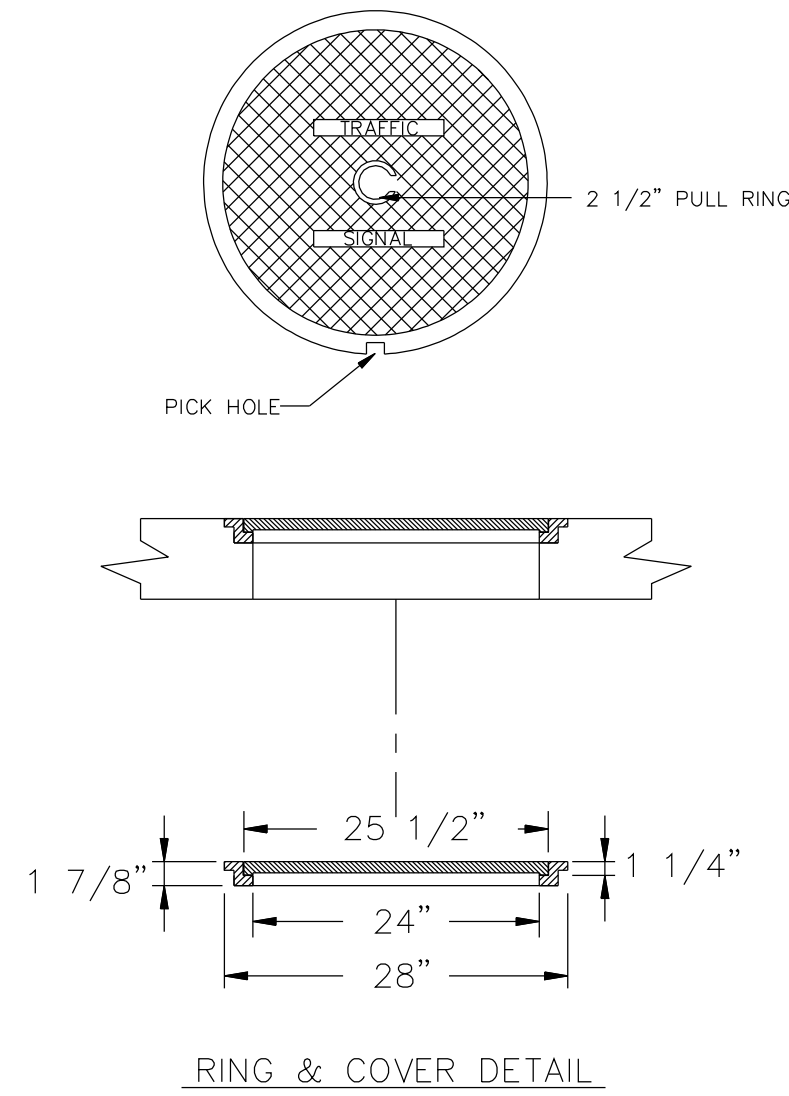
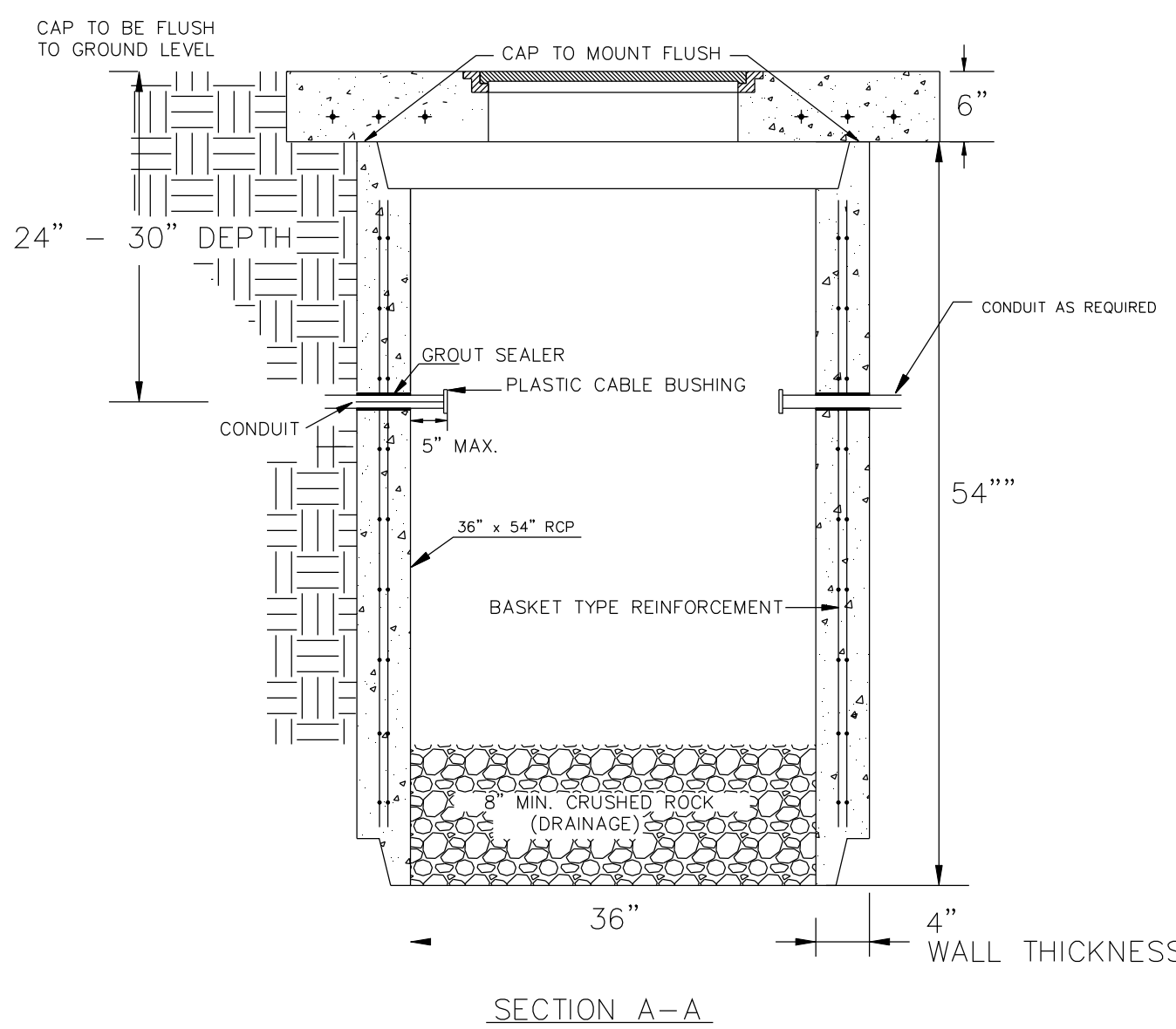

CONDUIT/DETECTOR WIRE INSTALLATION DETAILS

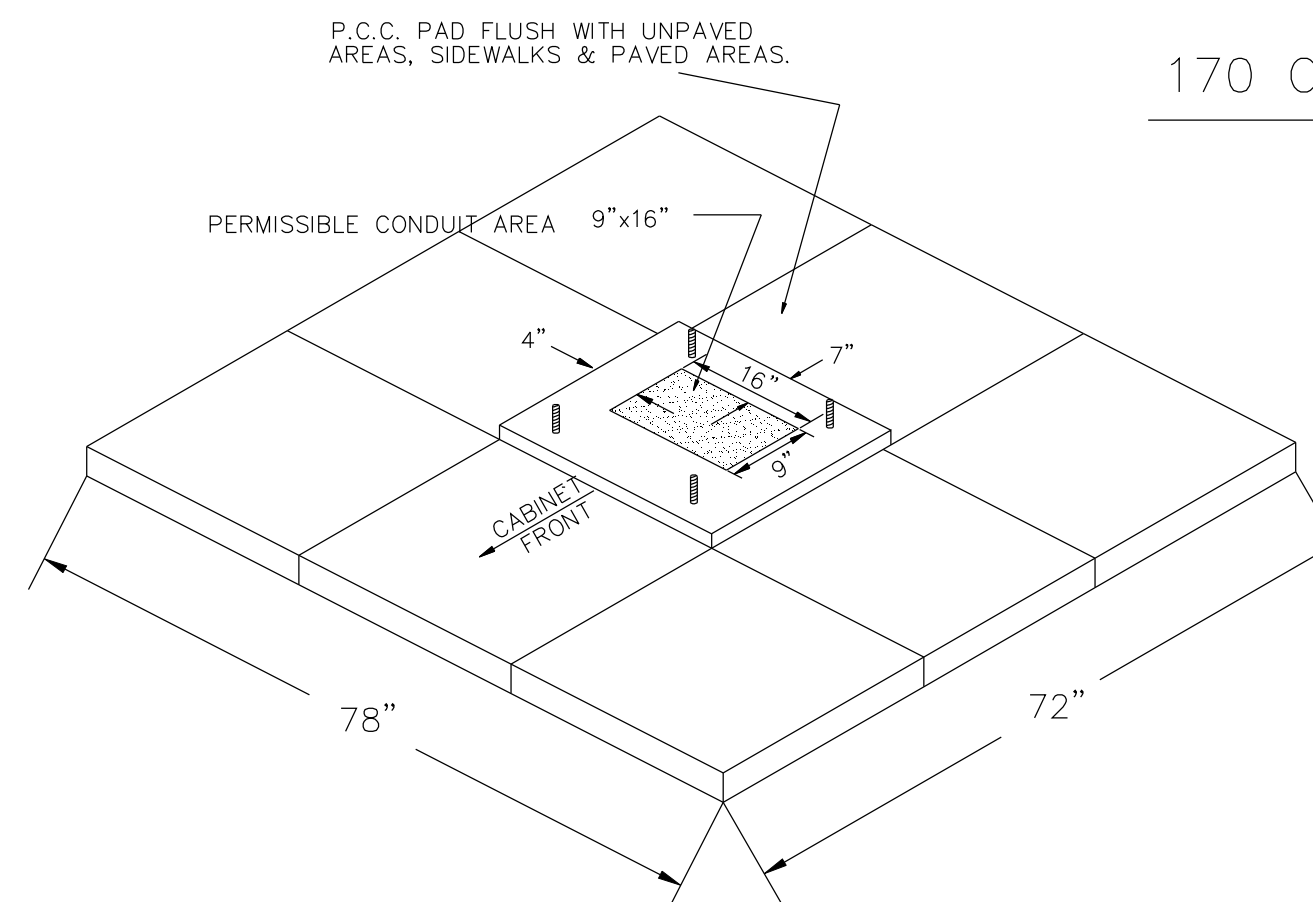
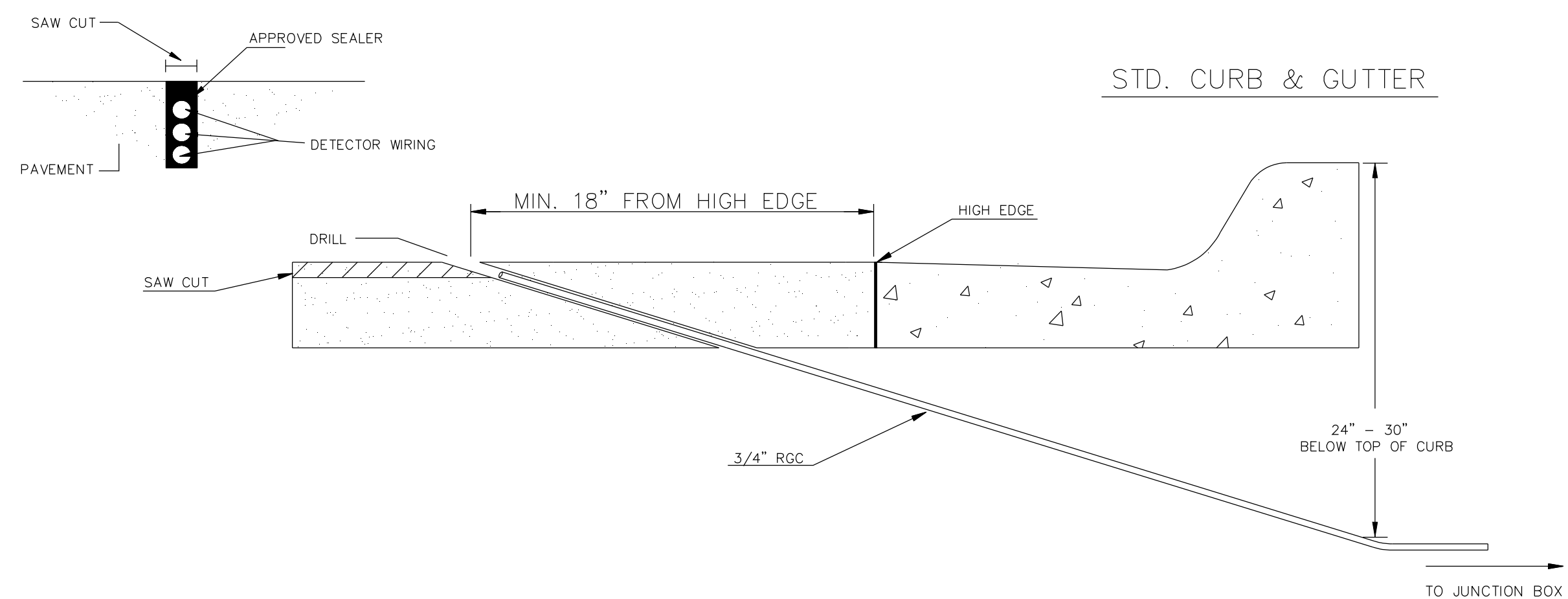

170 CONTROLLER PAD DETAILS

REBAR SHALL BE ASTM A615M GRADE 300 MEETING THE REQUIREMENTS OF SUBSECTION SPECIFICATIONS.

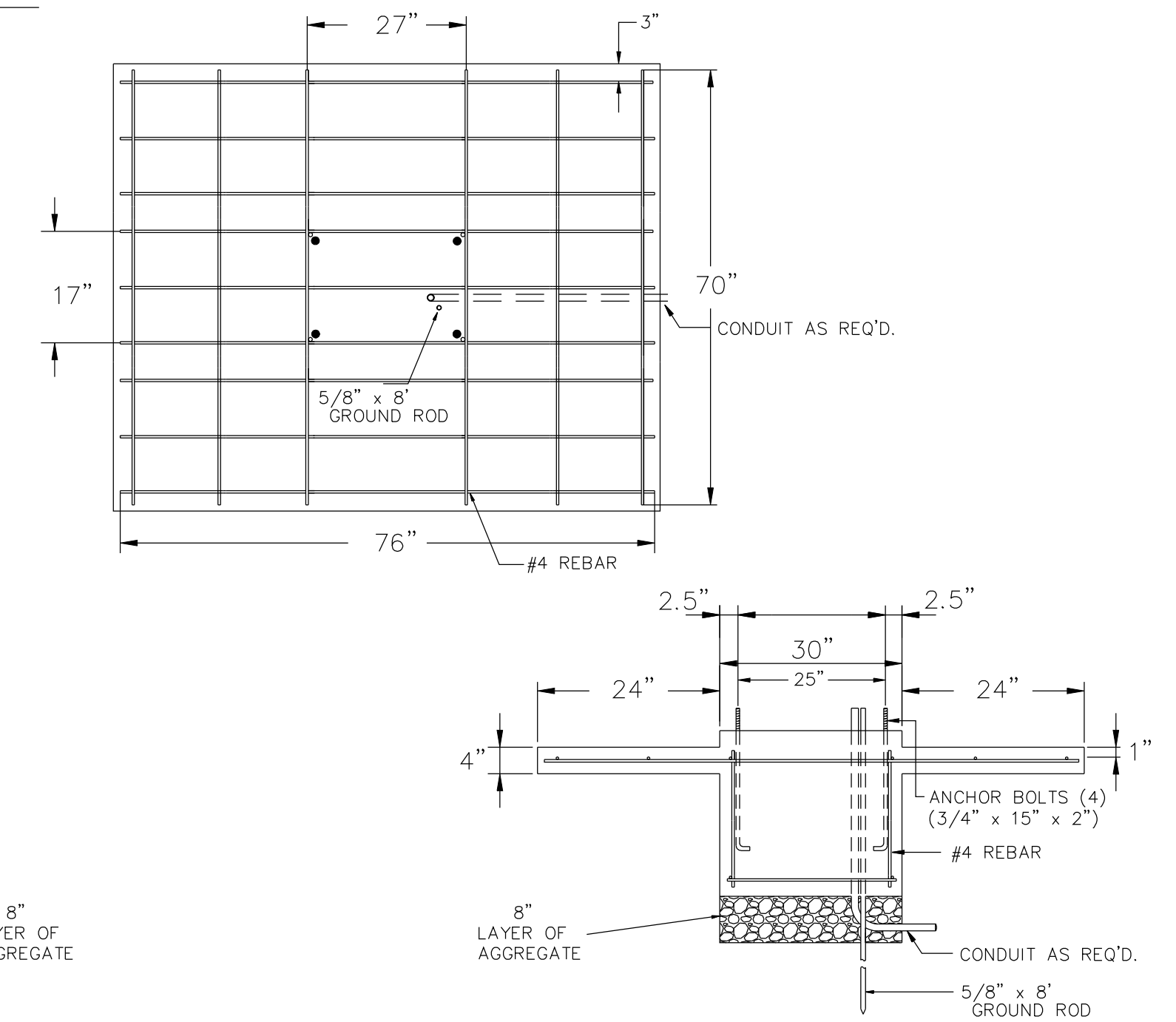
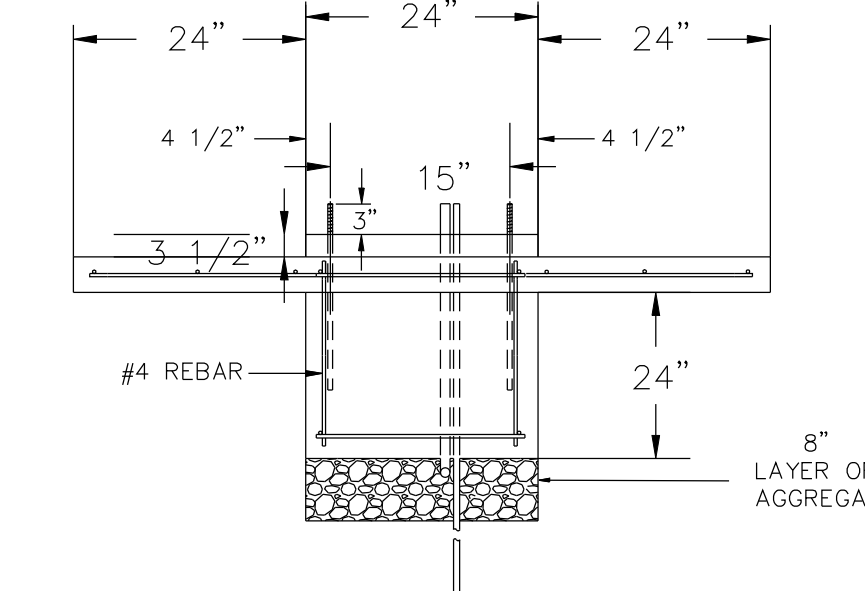

JUNCTION BOX DETAILS

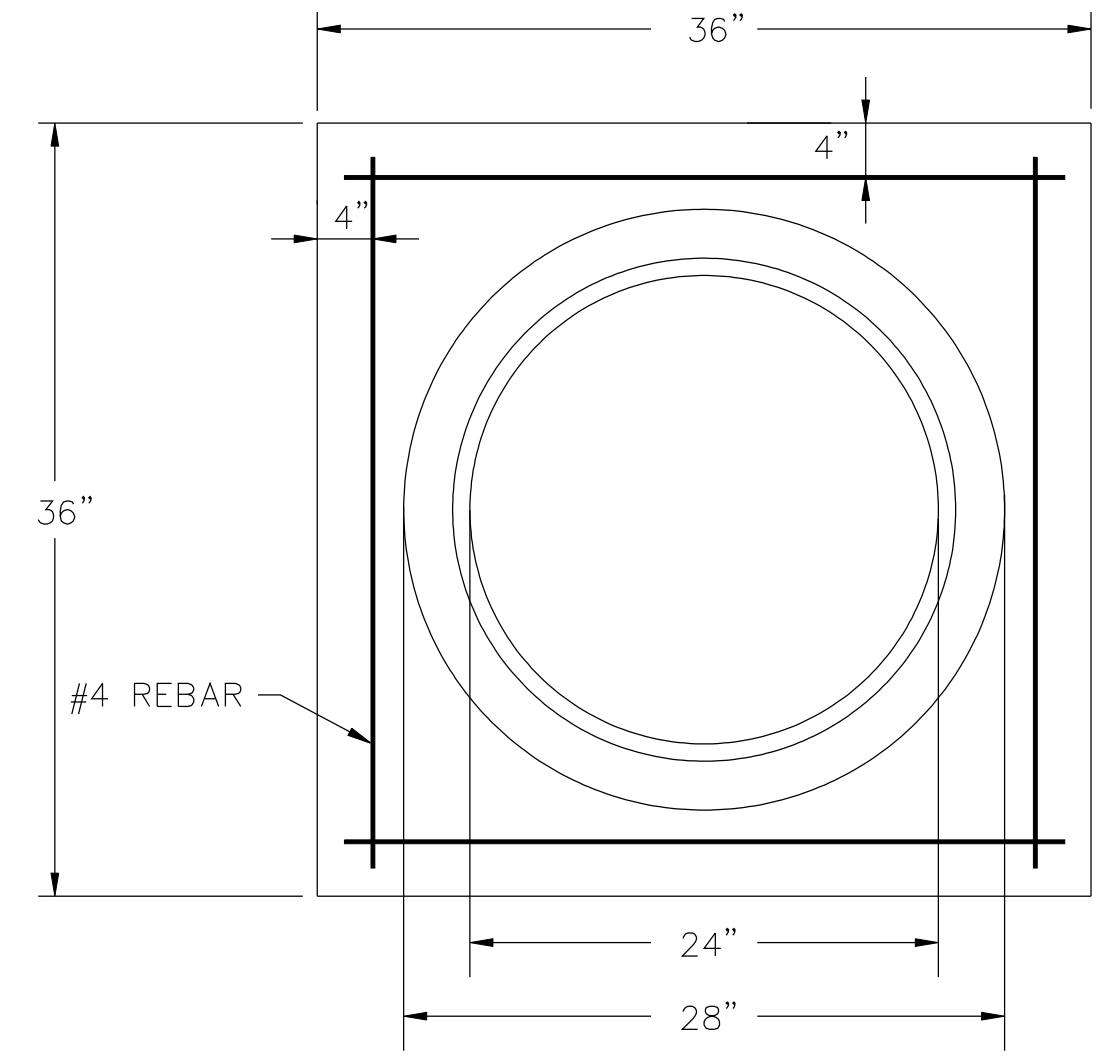
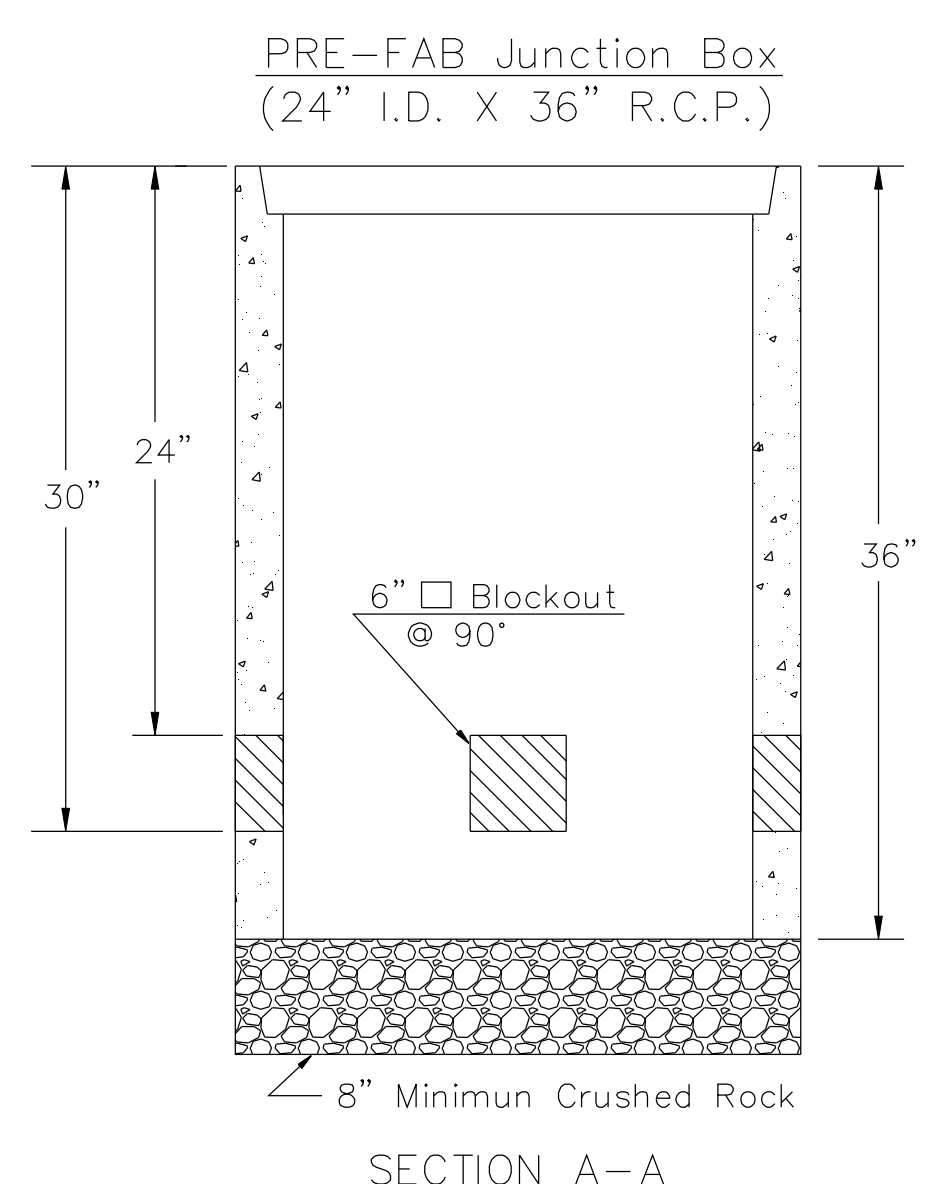

JUNCTION BOX CAP
36" x 36" x 6"
TOP OF CAP TO BE FLUSH WITH GROUND LEVEL.

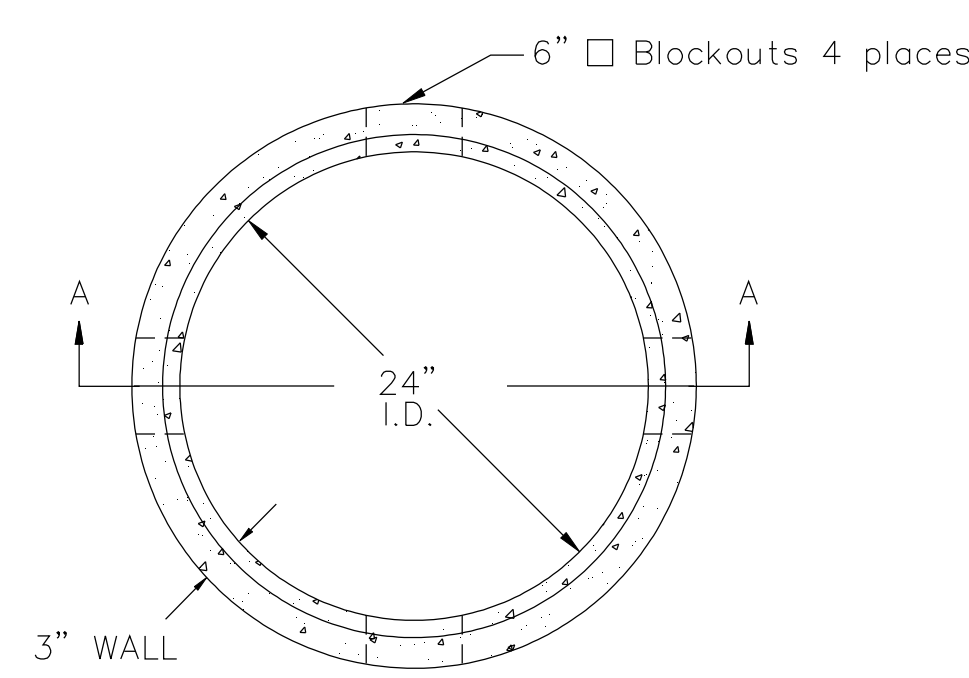

NOTES:

- SERVICE & JUNCTION BOX:
- CONDUIT CONNECTION TO BE FLUSH TO WITHIN 5" OF INSIDE FACE OF SIDE WALL, CONDUIT TO DRAIN INTO SERVICE BOX.
 - CONDUIT CONNECTIONS TO SERVICE BOX SHALL BE TERMINATED WITH PLASTIC CABLE BUSHING.
 - CONDUIT SHALL BE SEALED WITH APPROVED SEALER AT INSIDE WALL FACE.
 - ALL SERVICE & JUNCTION BOXES TO HAVE 8" OF CRUSHED ROCK.
- TRENCHING:
- DEPTH TO BE 30" MINIMUM WITH ROCK & STUBBLE FREE BACKFILL TO SERVE AS BEDDING MATERIAL. MAINTAIN MINIMUM CONDUIT DEPTH IN TRENCH.
 - BACKFILL TO BE COMPACTED IN 6" LOOSE LIFTS BY HAND OR MECHANICAL TAMPING TO A 95% STANDARD DENSITY.
- CONDUIT:
- SLOPE CONDUIT TO DRAIN AS DIRECTED BY THE ENGINEER.
 - 3" RIGID STEEL CONDUIT BTWN. SERVICE BOXES.
2" " " " " BTWN. SERVICE BOX AND POLE.
1 1/4" " " " " BTWN. SERVICE & JUNCTION BOXES.
3/4" " " " " BTWN. JUNCTION BOXES.
3/4" " " " " BTWN. JUNCTION BOX & DETECTOR LOOP SAW CUT

**SEE SERVICE BOX INSTALLATION FOR RING & COVER DETAILS.

	PROJECT DESCRIPTION		
	SERVICE/JUNCTION BOX, CONTROLLER PAD CONSTRUCTION/INSTALLATION DETAILS		
	PROJECT NUMBER 472 84907		
	DRAWN BY: T.M.	APPROVED BY:	REVISED: A.S.
DATE: Apr. 96		DATE: Jan.2006	
CITY OF WICHITA			
DEPARTMENT OF PUBLIC WORKS			
TRAFFIC ENGINEERING DIVISION PAUL D. GUNZELMAN, P.E. TRAFFIC ENGINEER		SCALE NO SCALE 19	